



VEGETABLE PREPARATION MACHINE CA-2V

Compact, variable speed vegetable slicer. "Brushless" technology: maximum efficiency.



DYNAMIC PREPARATION
COMMERCIAL VEGETABLE PREPARATION MACHINES

SALES DESCRIPTION

Compact ULTRA line.
Variable speed motor block + vegetable slicer attachment.

Equipped with "brushless" technology: powerful and efficient motors

- ✓ Maximum efficiency: maintain the torque throughout the speed range.
- ✓ Exclusive "Force control system": guarantee of a uniform and high quality result. Acoustic warning when the motor exceeds the pre-established force.
- ✓ Lightweight and compact design: they weigh less, they occupy less space.
- ✓ Improved air/water-tightness since no ventilation is required.
- ✓ They generate less noise: improved workplace environment.

A perfect cut

- ✓ High precision settings and comprehensive cutter and disc design aimed at obtaining a perfect cut.
- ✓ Gravity Slide System: Gravity product expulsion ramp allow to reconstruct the sliced product for storing or presentation purpose.
- ✓ Ejection disc included for the products that require its use.
- ✓ It can be fitted with a wide range of discs and grids of the highest cutting quality.
- ✓ By combining these accessories, more than 35 different types of cuts and gratings can be achieved.
- ✓ Possibility of extending its functionality by adding the cutter bowl with blades.

Built to last

- ✓ Sturdy construction in food-grade best quality materials.

Maximum comfort for the user

- ✓ Ergonomic design: product sliced in one single movement.
- ✓ Lateral product output: requires less space on the worktop and guides the product, avoiding splashes.
- ✓ Adjustable product ejection direction to adapt to the workflow in the preparation area.
- ✓ Recessed cored relief allows for any position in the kitchen, side walls, back wall, light and compact, this machine can fit.

- ✓ The electronic control panel is extremely simple to operate.

Maintenance, safety, hygiene

- ✓ Lever and lid easily removable for cleaning purposes.
- ✓ Stainless steel, dishwasher-safe discs. The removable blades allow for an even more thorough and efficient cleaning.
- ✓ Combination of safety systems: head, cover, power switch.
- ✓ Complete error warning system.
- ✓ Appliance certified by NSF International (regulations on hygiene, cleaning and materials suitable for contact with foods).
- ✓ 100% tested.

INCLUDES

- ✓ Variable speed motor block.
- ✓ Vegetable slicer attachment.
- ✓ Gravity product expulsion ramp.
- ✓ Inner collecting container.
- ✓ Ejection disc.
- ✓ Universal grid cleaner QC-U.

OPTIONAL

- Cutter bowl.
- Hub with toothed blades.
- Hub with smooth blades.
- Hub with perforated blades.

ACCESSORIES

- Cutter bowl
- FCS slicing discs
- FCOS rippled slicing disc
- FMS dicing grid
- FFS chipping grid
- FCES julienne discs
- SHS shredding & grating discs
- Hubs with blades
- Disc and grid packs - Compact Line
- Déli-cut cutting kit - Compact Line
- Universal grid cleaner QC-U
- Inner collection container for delicate cuts
- Disc and grid holder

SPECIFICATIONS

Hourly production: 350 kg
 Inlet opening: 89 cm²
 Disc diameter: 180 mm
 Speed as veg. slicer: 300 rpm - 1000 rpm
 Total loading: 1100 W

External dimensions (W x D x H)

Width: 378 mm
 Depth: 309 mm
 Height: 533 mm



SAMMIC, S.L. · Basarte, 1
 20720 AZKOITIA (Gipuzkoa) · SPAIN

product sheet
 updated 17/12/2025



VEGETABLE PREPARATION MACHINE CA-2V

Compact, variable speed vegetable slicer. "Brushless" technology: maximum efficiency.



Net weight: 12.9 kg
Noise level (1m.): <70 dB(A)
Background noise: 32 dB(A)
Crated dimensions
285 x 385 x 714 mm
Volume Packed: 0.08 m³
Gross weight: 17.2 kg

AVAILABLE MODELS

1050962	Vegetable preparation machine CA-2V 230/50-60/1
1050965	Vegetable preparation machine CA-2V 230/50-60/1 UK
1050970	Vegetable preparation machine CA-2V 120/50-60/1

* Ask for special versions availability

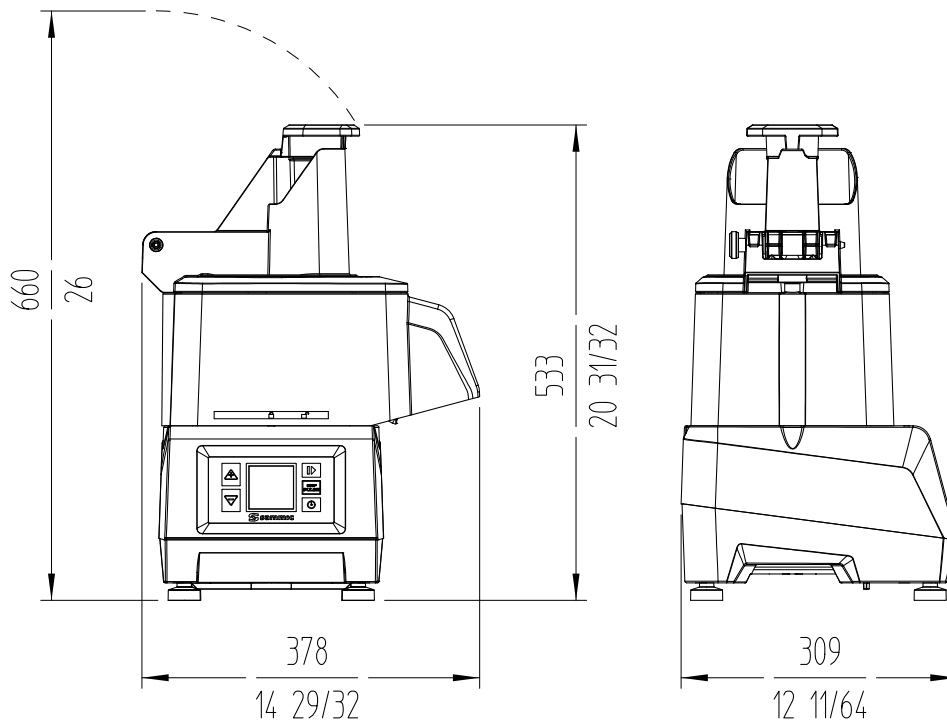

DYNAMIC PREPARATION
COMMERCIAL VEGETABLE PREPARATION MACHINES

sammic | sammic.com
Food Service Equipment Manufacturer

Polígono Basarte, 1. phone +34 943 15 72 36
20720 Azkoitia, Spain sales@sammic.com



Project	Date
Item	Qty
Approved	

product sheet
updated 17/12/2025