



POTATO PEELER PI-10

10 kg / 22 lb load per cycle.



DYNAMIC PREPARATION
COMMERCIAL POTATO PEELERS



SALES DESCRIPTION

- ✓ Stainless steel construction commercial potato peeler.
- ✓ Also suitable to peel carrots and other similar products.
- ✓ 0-6 min timer.
- ✓ Removable turntable for easy cleaning.

Robust and efficient construction

- ✓ Construction in stainless steel.
- ✓ Lateral stirrers covered with silicon carbide abrasive (approved by NSF).
- ✓ Aluminium base plate lined with silicon carbide abrasive (approved by NSF), easily removable for cleaning purposes.

User comfort

- ✓ 0-6 min timer.
- ✓ Possibility of continuous operation.

Maximum safety and hygiene

- ✓ Auto-drag of waste to the drain.
- ✓ BPA-free liftable transparent cover, complete with locking and safety device.
- ✓ Aluminium door with hermetic seal and safety device.
- ✓ Waterproof control board (IP65): Improved reliability against moisture and water splash.
- ✓ Water inlet system with non-return air break.
- ✓ Auxiliary contact for external electric valve.

Energy efficiency

- ✓ Energy efficiency owing to engine optimisation.

OPTIONAL

- Stainless steel floor stand.
- Filter with no-foam feature.

ACCESSORIES

- Stands for potato peelers
- Filters for potato peelers M / PI / PES

SPECIFICATIONS

Hourly production: 200 kg / 240 kg
 Capacity per load: 10 kg
 Timer (min-max): 0' - 6'
 Single Phase: 550 W
 Three phase: 370 W

External dimensions (W x D x H)

435 x 635 x 668 mm

External dimensions with stand

433 x 638 x 1040 mm

Net weight: 36/34 kg

Noise level (1m.): 70 dB(A)

Background noise: 32 dB(A)

AVAILABLE MODELS

1000608	Potato peeler PI-10 120/60/1
1000650	Potato peeler PI-10 230-400/50/3N
1000651	Potato peeler PI-10 230/50/1
1000652	Potato peeler PI-10 220-380/60-3N
1000653	Potato peeler PI-10 220/60/1

* Ask for special versions availability



SAMMIC, S.L. · Basarte, 1
20720 AZKOITIA (Gipuzkoa) · SPAIN

product sheet
updated 10/03/2026



POTATO PEELER PI-10

10 kg / 22 lb load per cycle.



DYNAMIC PREPARATION
COMMERCIAL POTATO PEELERS

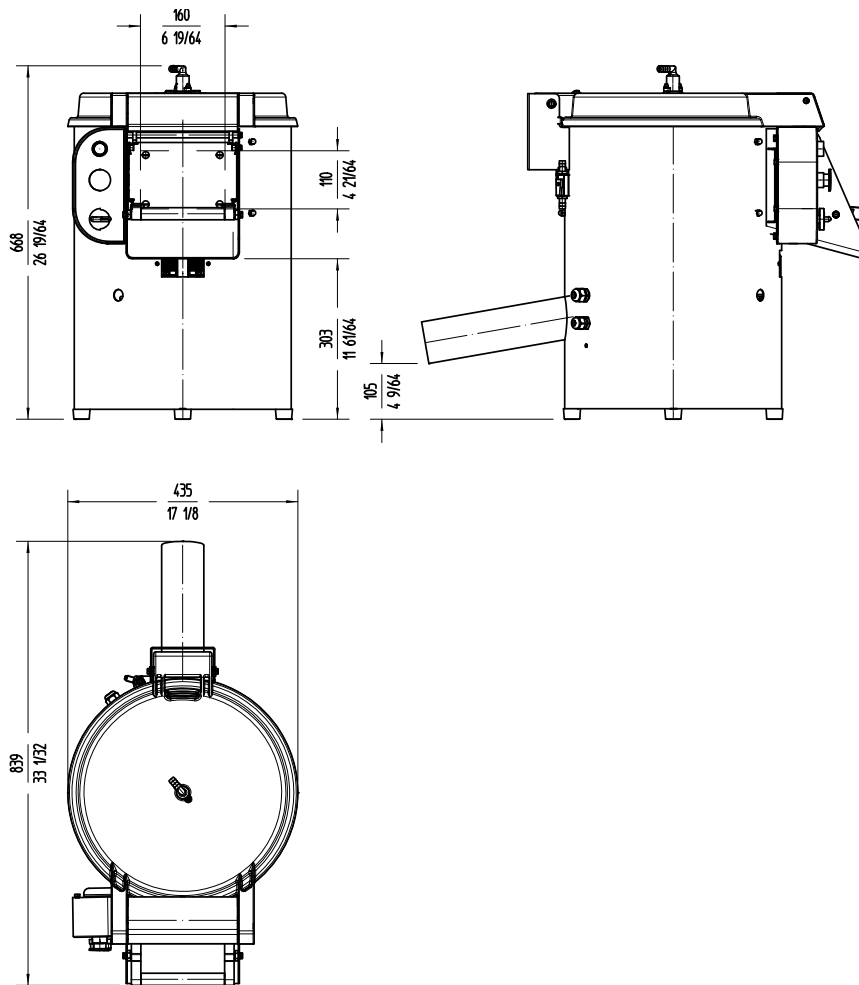

 **sammic** | sammic.com
Food Service Equipment Manufacturer

Polígono Basarte, 1. phone +34 943 15 72 36
20720 Azkoitia, Spain sales@sammic.com



Project	Date
Item	Qty
Approved	

product sheet
updated 10/03/2026