

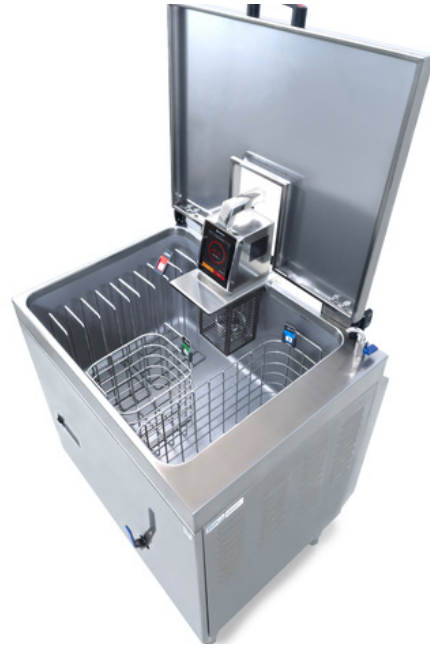

HEATED TANK WITH HINGED LID FOR SMARTVIDE XL: 120P LID



FOOD PRESERVATION AND SOUS-VIDE
SMARTVIDE SOUS-VIDE COOKERS



SALES DESCRIPTION

Large capacity tank with integrated hinged lid: maximum efficiency. Connected to and controlled by SmartVide XL.

Connected to and controlled by SmartVide XL to reach the set temperature faster.

- ✓ Connected to and controlled by SmartVide XL immersion circulator.
- ✓ Intelligent interaction allows for optimization of heating times.
- ✓ This is specially useful to cook very cold or frozen products.
- ✓ Stainless steel made.
- ✓ Complete with filling tap and drain key.
- ✓ The integrated hinged lid reduces steam emissions and improves energy consumption due to thermal management.

* Please note: SmartVide immersion circulator must be ordered

separately.

SPECIFICATIONS

Temperature

Display precision: 0.1°F

Range: 41°F - 203°F

Time

Resolution: 1'

Cycle duration: 1' - 99 h

General features

Maximum recipient capacity: 30 gal

External dimensions (W x D x H): 29.1" x 24.8" x 36.9-38.9"

AVAILABLE MODELS

1180414 Heated tank 120P LID 208-240/50-60/1 · 120 l / 30 gal

1180415 Heated tank 120P LID 230/50-60/1 · 120 l / 30 gal

* Ask for special versions availability



SAMMIC, S.L. · Basarte, 1
20720 AZKOITIA (Gipuzkoa) · SPAIN

product sheet
updated 26/09/2025



HEATED TANK WITH HINGED LID FOR SMARTVIDE XL: 120P LID



FOOD PRESERVATION AND SOUS-VIDE
SMARTVIDE SOUS-VIDE COOKERS

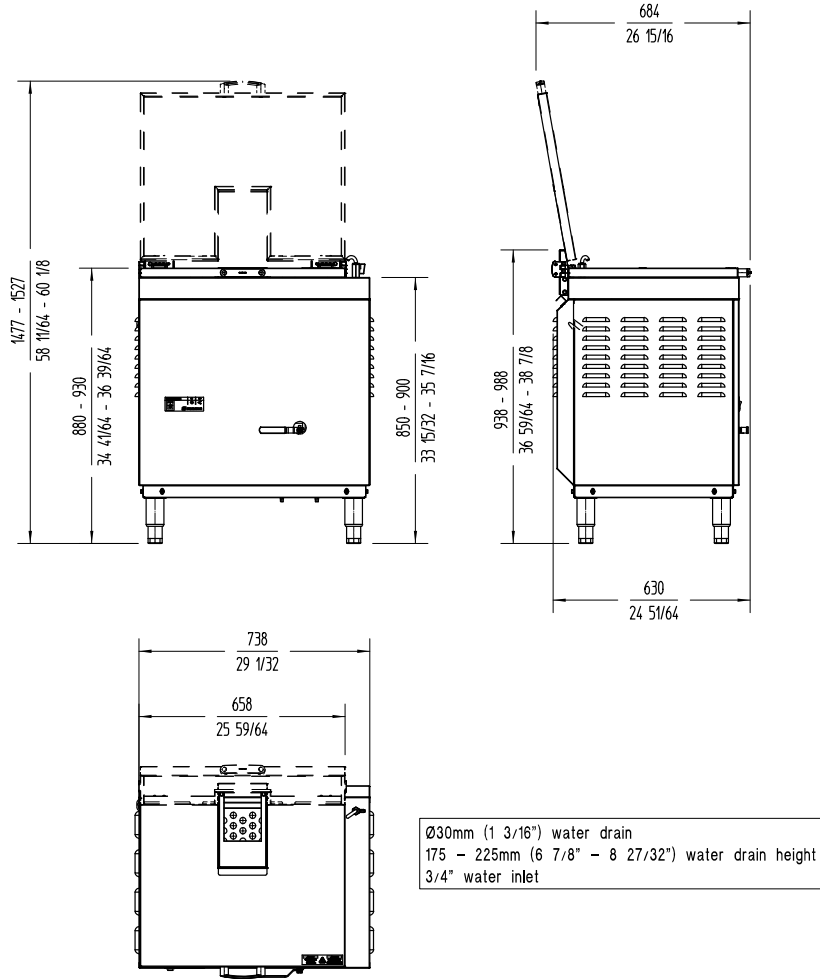

sammic | sammic.us
Food Service Equipment Manufacturer

usa@sammic.com phone +1 (224) 307-2232
 1225 Hartrey Avenue toll free +1 844 275 3848
 60202-1056 Evanston, IL

Project	Date
Item	Qty
Approved	

product sheet
updated 26/09/2025