



REFRIGERATION

SERVING THE FOOD INDUSTRY SINCE 1951

Refrigerated Topping Rails with Stainless Steel Cover

| | | | |
|--------|----------------|----------------|----------------|
| ITEM: | 46658 | 46657 | 46497 |
| MODEL: | RS-CN-0004-PSS | RS-CN-0006-PSS | RS-CN-0009-PSS |



46658



46657



46497

High-Performance

Compact, high-performance refrigerated rail designed to keep pizza toppings chilled and easily accessible during food preparation. Feature consistent temperature control, durable stainless-steel construction, and a convenient open-top lid design compatible with standard food pans. Ideal for busy commercial kitchens requiring reliable, efficient ingredient storage.

- Digital LED temperature display
- Stainless steel cover
- Compatible for 2.5" - 4" deep food pans

Telephone: 1-800-465-0234

Fax: (905) 607-0234

Email: sales@omcan.com

Website: www.omcan.com



Authorized Dealer



Made in China



REFRIGERATION



TECHNICAL SPECIFICATION

| Features | 47" wide | 59" wide | 79" wide |
|---------------------------|---|---|---|
| Item | 46658 | 46657 | 46497 |
| Model | RS-CN-0004-PSS | RS-CN-0006-PSS | RS-CN-0009-PSS |
| Capacity | 4 x GN 1/3 Pan | 6 x GN 1/3 Pan | 9 x GN 1/3 Pan |
| Refrigerant | R600A | R600A | R600A |
| Electrical | 115V / 60Hz / 1Ph | 115V / 60Hz / 1Ph | 115V / 60Hz / 1Ph |
| Cooling System | Static | Static | Static |
| Temperature Range | 8°C to 2°C (46°F to 36°F) | 8°C to 2°C (46°F to 36°F) | 8°C to 2°C (46°F to 36°F) |
| Power | 140 W | 140 W | 140 W |
| Amp | 1.6 A | 1.8 A | 2 A |
| Running Load Amperage | 1.7 A | 1.85 A | 2.1 A |
| Number of Doors | 1 Lift-up Door | 1 Lift-up Door | 2 Lift-up DoorS |
| Interior Dimensions (WDH) | 33.5" x 12" x 6.5" | 45.3" x 12" x 6.5" | 65" x 12" x 6.5" |
| Net Weight | 81.6 lb. (37 kg.) | 99.2 lb. (45 kg.) | 123.5 lb. (56 kg.) |
| Net Dimensions (WDH) | 47" x 15.5" x 11" (close lid) 24" (height open lid) 1200 x 395 x 280mm (close lid) 617mm (height open lid) | 59" x 15.5" x 11" (close lid) 24" (height open lid) 1500 x 395 x 280mm (close lid) 617mm (height open lid) | 79" x 15.5" x 11" (close lid) 24" (height open lid) 2000 x 395 x 280mm (close lid) 617mm (height open lid) |

>> This equipment is intended for use in an indoor environment where ambient temperature and humidity do not exceed 24°C / 75°F and 55% relative humidity.

TECHNICAL DRAWING

| Item | 46658 | 46657 | 46497 |
|------|--------------|------------|---------------------|
| L1 | 47" (1200mm) | 59" (1500) | 78.7" (2000) |
| L2 | 33" (850) | 45" (1150) | 65" (1650) |
| L3 | 34" (851) | 45" (1151) | 32" x 2 (819mm x 2) |

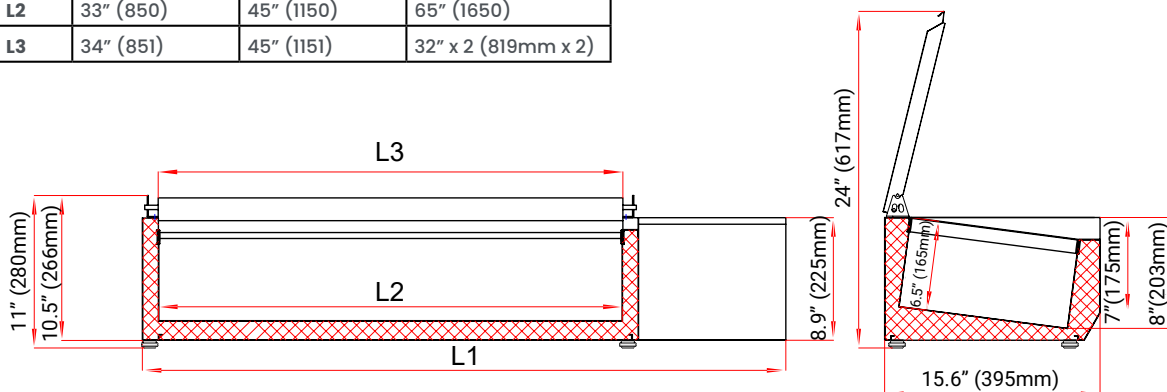

Dimensions rounded up to the nearest tenth inch or millimeter. Specifications subject to change without notice.