



MX1300XTX

Reprogrammable Hi-Power Blender with 64 oz. BPA-Free Copolyester Container



*Made in USA with US and foreign parts.

ELECTRICAL

Voltage: 120V

Frequency: 60Hz

Watts: 1560W

Amps: 12.5A

Plug Type: NEMA 5-15P

Cord Length: 6 feet



MAIN FEATURES

- Heavy-duty, high-performance 3½ peak HP motor with adjustable speed controls is the strongest in its class. It powers through the toughest ice and frozen fruit mixtures in seconds.
- Super-high 30,000 RPM motor speed for the smoothest consistencies.
- 4 reprogrammable beverage stations for perfect results every time.
 - Factory-set programs for the most popular beverage types
 - Easy to create your own customized programs—fully reprogrammable directly on the keyboard with no need for a USB or computer for programming
- Daily and total drink counter display.
- Variable speed and time selections for maximum control over consistencies.
- Dual PULSE feature with reprogrammable speed control.
- Easy-to-clean electronic-membrane keypad.
- The Raptor® 64 oz. stackable BPA-free copolyester container.
 - Ultra-aggressive blade and jar design delivers smoother consistencies and faster results
 - Unbreakable, dishwasher-safe construction
- Optional sound enclosure easily retrofits to base for noise reduction.
- High-performance, high-impact stainless steel blade is user replaceable for easy servicing.
- User-replaceable, metal-on-metal stainless steel coupling system for durability and reliability.
- Easily removable container cover with removable clear cap lets you add ingredients and reduce pressure during hot food blending.
- One-piece, dishwasher-safe, removable jar pad.
- Recommended for 75+ cycles per day.
- Limited Three-Year Motor and Two-Year Parts and Labor Warranty.

SALES FEATURES

Get smooth, consistent results every time with the Waring® MX1300XTX. This heavy-duty 3½ peak HP blender teams up with The Raptor® blade and jar assembly for maximum power and efficiency. It's ferocious enough for everything from smoothies and frozen drinks to thick spreads, desserts, dressings, and all types of food preparation. The sturdy base features an easy-to-clean electronic-membrane keypad with blue backlit LCD screen and four reprogrammable beverage stations. Blend 75+ cycles per day. Perfect for a busy bar, health facility, school, or coffee shop.

Reprogrammable Hi-Power Blender with 64 oz. BPA-Free Copolyester Container

MX1300XTX



@waringcommercial

©2022 Waring Commercial
314 Ella T. Grasso Avenue, Torrington, CT 06790
Tel. 800-492-7464 • Fax 860-496-9008

waringcommercialproducts.com



Reprogrammable Hi-Power Blender with 64 oz. BPA-Free Copolyester Container MX1300TX

PARTS & ACCESSORIES

- | | | | |
|---|--|---|--|
|  | CAC90
64 oz. Stainless Steel Container |  | CAC95-12
64 oz. Green Copolyester Container |
|  | CAC93X
48 oz. Copolyester Container |  | CAC95-28
64 oz. Orange Copolyester Container |
|  | CAC93X-03
48 oz. Yellow Copolyester Container |  | CAC116
Blending Assembly Kit and Retainer Ring Kit |
|  | CAC93X-06
48 oz. Blue Copolyester Container |  | CAC119
Retainer Ring Wrench |
|  | CAC93X-10
48 oz. Purple Copolyester Container |  | CAC158
Blending Assembly Kit |
|  | CAC93X-12
48 oz. Green Copolyester Container |  | CAC159
Retainer Ring Kit |
|  | CAC93X-28
48 oz. Orange Copolyester Container |  | CAC160
Drive Coupling |
|  | CAC95
The Raptor® – Aggressive, All-Purpose, Stackable 64 oz. BPA-Free Copolyester Container |  | CAC161
Drive Coupling Removal Tool |
|  | CAC95-03
64 oz. Yellow Copolyester Container |  | CAC169
Spatula – Custom designed for use with MX Series Blenders |
|  | CAC95-06
64 oz. Blue Copolyester Container |  | SE1000
Large Sound Enclosure |
|  | CAC95-10
64 oz. Purple Copolyester Container |  | SE500
Small Sound Enclosure |

DIMENSIONS

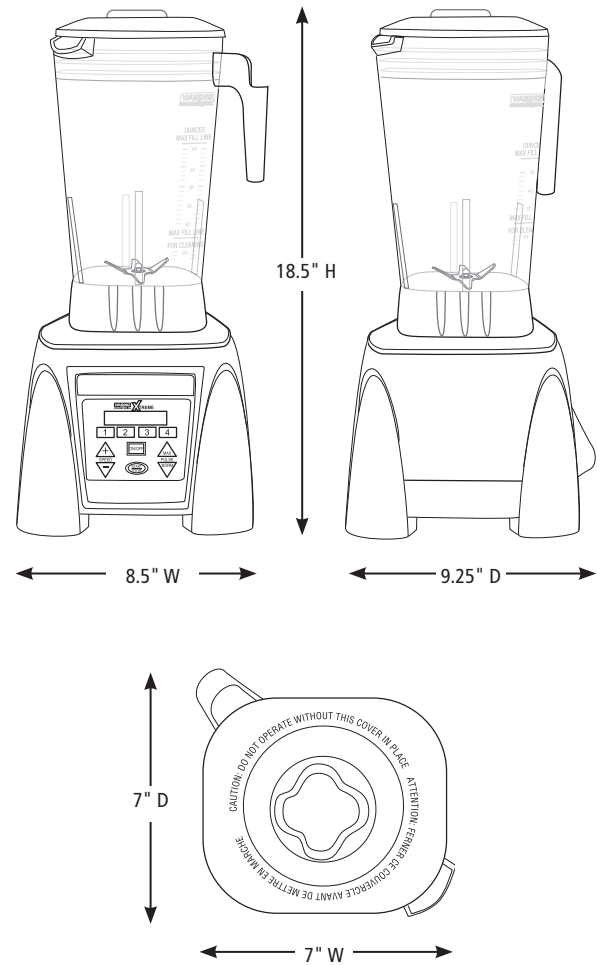

Out-of-Box Weight: 14.64 lb.

ORDERING INFORMATION	#STD. PKG.	GIFTBOX WEIGHT	CUBIC FEET	BOX DIMENSIONS D X W X H	UPC	CASE PKG.	MC WEIGHT	MC DIMENSIONS D X W X H	MBC
MX1300TX– Reprogrammable Hi-Power Blender with 64 oz. BPA-Free Copolyester Container	1	16.9 lb.	1.048	11.5" x 10.25" x 15.375"	040072017025	1	17.9 lb.	11.625" x 10.875" x 16.125"	10040072017022



@waringcommercial

©2022 Waring Commercial
314 Ella T. Grasso Avenue, Torrington, CT 06790
Tel. 800-492-7464 • Fax 860-496-9008

waringcommercialproducts.com

22WC083134 / REV 5/22