

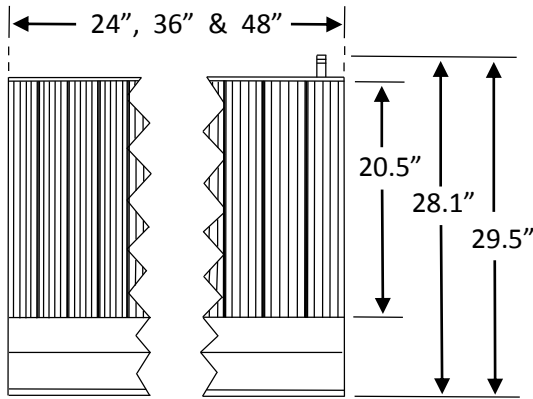

BROILERS

Radiant Style BR Series
24", 36" & 48" widths



Model BR24

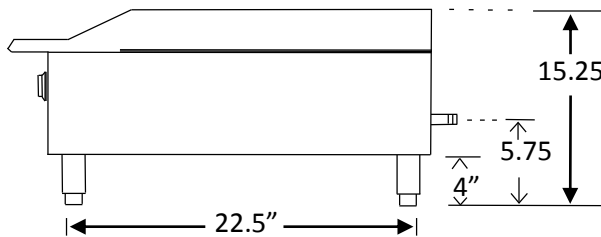

Standard Features, Benefits & Options

CONSTRUCTION: 24", 36" & 48" wide models available. Easy cleaning, corrosion resistant stainless steel finish. Double wall construction, insulated for energy efficiency. 5¼" bull-nose landing. 4" tall adjustable legs. ¾" grease trough. Stainless steel drip tray.

CONTROLS: Castle griddles are equipped with brass gas valves, front accessible automatic standing pilots, pressure regulators and cool to the touch control knobs with securing set screws.

BURNERS: Efficient stainless steel "U" shaped burners are rated at 35,000 BTU's each provide even heating across the cooking surface. 1 burner per 12" increment.

BROILER: Heavy 6" wide cast iron tilt-able top grates. 10 gauge stainless steel radiants cover the burners.

TESTING: Optimal pressure is 5" WC for natural gas, 10" WC for propane. ETL design & ETL Sanitation (ANSI-NSF4) certified.

Model #	Width x Depth		Burners Total BTU	Ship Wgt.	
	in.	mm		lbs.	kg.
BR24	24.03"	610	2	150	68
	x 29.5"	x 749	70,000		
BR36	35.84"	910	3	218	99
	x 29.5"	x 749	105,000		
BR48	47.65"	1210	4	300	136
	x 29.5"	x 749	140,000		



Comstock-Castle Stove Co. • 119 W. Washington St. • Quincy, IL. 62301
Tel.: 217-223-5070 • Fax.: 217-223-0007 • Web: www.castlestove.com

