

Unit Information

120 volts – 60 Hz – 13 Amp
 Variable Speed From 1,000 to 17,000 Rpm's
 48 oz. Stackable Break Resistant Container
 Limited 2 Year Motor Warranty & 1 Year
 Parts and Labor

WARING COMMERCIAL Torq 2.0 Blender Variable Speed Control TBB175

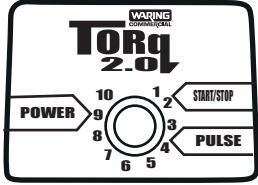

035299
 Control Panel Overlay

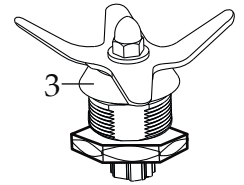
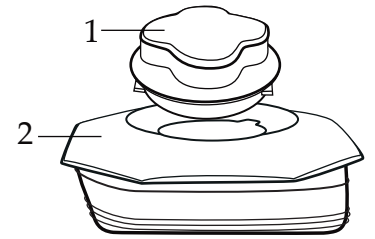
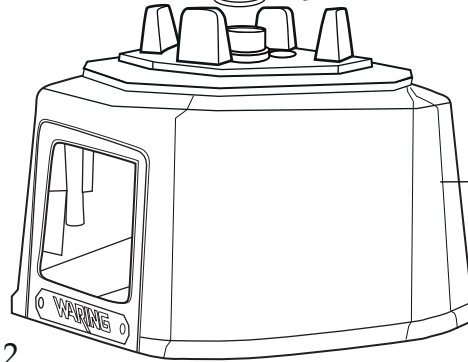
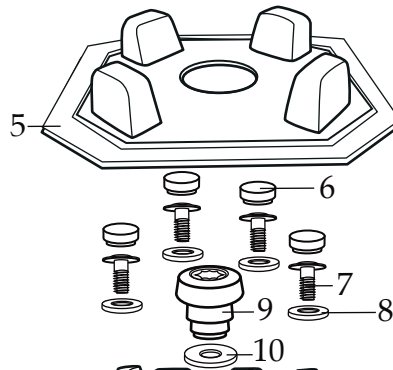

013304
 NSF Seal

503482
 Container with Blending Assembly

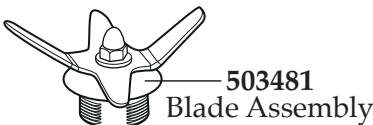
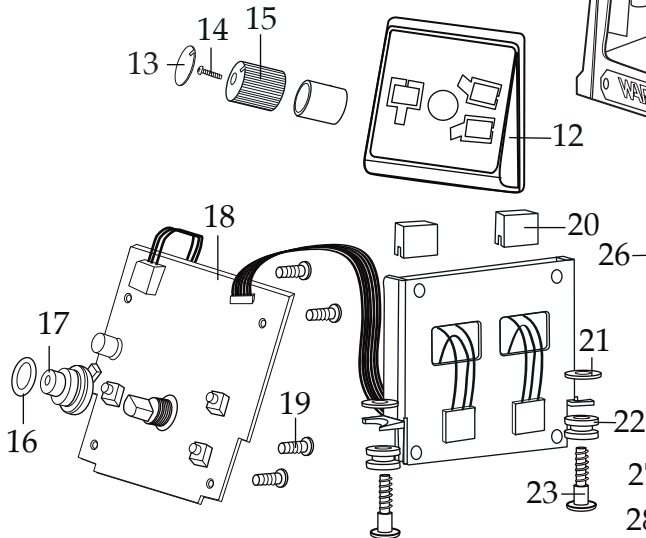

503481
 Blade Assembly



024271
 O Ring

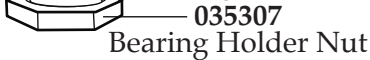

035307
 Bearing Holder Nut

035465
 Blending Assembly
 (with O ring and bearing holder nut)

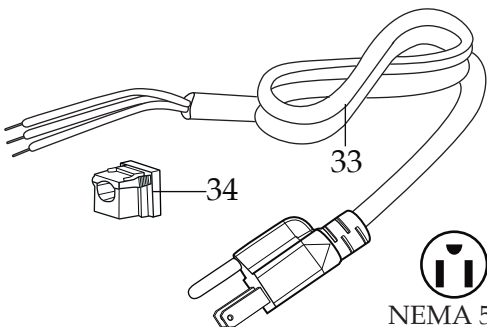
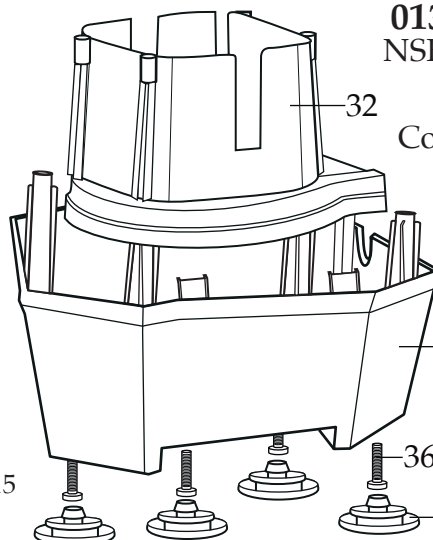
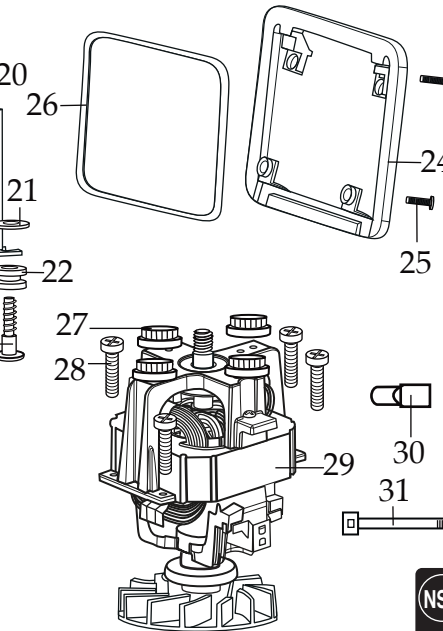

NEMA 5-15

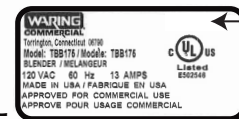

Date Code Location
 YY|MM|DD
 year year month month day day

Illustration#	Part#	Description
1	028769-E	Eastman Jar Lid Cover
2	035238-V	Vinyl Jar Lid
3	035465	Blending Assembly (with O ring and bearing holder nut)
4	035239	48 oz. Stackable Container ONLY
5	035885 035091	Jar Pad (<i>changed after 8/2/2018</i>) Jar Pad (use 035885)
6	035085	Hole Plug (4 required)
7	034275	Sems (4 required)
8	034273	B Gasket (4 required)
9	037034 035251	Drive Coupling 2 Gen. (<i>on units after 11/15/2019</i>) Drive Coupling
10	037033	Coupling Washer (<i>on units after 11/15/2019</i>)
11	503609 503460-175	Top Housing with Badge (<i>on units after 9/28/2022</i>) Top Housing Assembly
12	035281	Control Housing Front Bezel (<i>on units after 9/28/2022</i>)
13	035757	Knob Cover
14	026267	Screw
15	036498	Speed Control Knob
16	018389	O Ring
17	036499	Speed Control Knob Insert
18	035342 034905	Control Panel (<i>on units after 2/1/2018</i>) TBB175 Control Panel Assembly
19	035090	Screw (4 required)
20	034900	PCB Cushion (2 required)
21	013604	Washer (2 required)
22	034904	Rubber Grommet (2 required)
23	034902	Sems (2 required)
24	035237	Control Housing Back Bezel (<i>on units after 9/28/2022</i>)
25	035090	Screw (4 required)
26	038576	Top Housing Control Seal (<i>on units after 9/28/2022</i>)
27	034272	A Gasket (4 required)
28	034274	Screw (4 required)
29	035815 034276	Chiaphua Motor with Sensor (<i>on units after 6/4/2021</i>) ECM Motor /KB500
30	012409	Small Crimp Connectors (5 required)

Illustration#	Part#	Description
31	013731	Cable Ties (6 required)
32	503483	Motor Housing with Dampeners
33	035124 026925	Cordset (on units after 4/14/2018) Cordset
34	033619 007556	Strain Relief (on units after 4/14/2018) Strain Relief
35	035079 503480	Bottom Housing Bottom Housing with Feet
36	034274	Screw (4 required)
37	035088	Foot (4 required)

