

ED3-72 Display Case

UL



Drive foodservice profits with display cases from Alto-Shaam. LED lighting and mirrored back doors enhance food appearance and boost impulse sales. To not only look but taste great, food is held at optimal, precise temperatures with Halo Heat® technology and top ceramic heaters. Multiple access points and a removable back work shelf makes unloading and loading food effortless for employees. Reduce labor and cleaning time with removable back doors and side panels, and a lifting glass front.



ED3-72 with Legs



ED3(SYS)-72
With Stationary Base

Standard features

- Fanless, waterless Halo Heat technology
- Overhead LED lighting
- Adjustable thermostats 1-10 per heat zone for top and bottom heat
- Ceramic top heaters
- Operator-side work shelf and cutting board
- Sliding back doors with mirrored glass
- Tempered glass front with self-supported lifting mechanism
- Removable back doors and side glass panels
- One set of 4" [102mm] legs with rubber feet
- Five [5] pan zones to hold standard pan sizes [GN]
- Two [2] heat zones
- Two [2] heat-on indicator lights
- Four [4] long pan dividers [1002584]
- Five [5] short pan dividers [1002621]
- Fifteen [15] short pan dividers [11318]

Configuration

- ED3-72 with 4-inch legs and rubber feet [standard]
- ED3(SYS)-72 with stationary base

Electrical

- 208V, 50/60 Hz, 1PH
- 240V, 50/60 Hz, 1PH

Options and Accessories

Panel Color [select one]

- Black, standard
- Stainless steel, optional

End Glass [select one]

- Clear glass, standard
- Solar bronze glass, optional..... [5011353]

Additional

- Temperature gauge..... [GU-48153]
- Right-mounted scale platform [5001307]
- Left-mounted scale platform [5001308]
- Work shelf with gravy lane [5005639]
- Pan insert (4" deep [100mm]) [1001990]
- 1/3 Pan cover-up bar [1008014]
- Sheet pan divider bar package [5002803]

Extended warranty

- One-year warranty extension

Pan* Capacity			
Pan Size	Pan Dimensions		Qty.
Full-Size & One-Third**:	12" x 20" x 2-1/2" [GN 1/1]		5
	12" x 6" x 2-1/2" [GN 1/3]		5
Half-Size & One-Third**:	12" x 10" x 2-1/2" [GN 1/2]		10
	12" x 6" x 2-1/2" [GN 1/3]		5
Full-Size Sheet Pans:	18" x 26" x 1"		3
Max. Capacity/Volume:	80 lbs [36 kg]	50 qts [60 L]	

* Pans are not included with display case.
** Will also accept 4" [100mm] deep pans.



ED3-72 Display Case



DIMENSIONS

ED3-72 with Legs

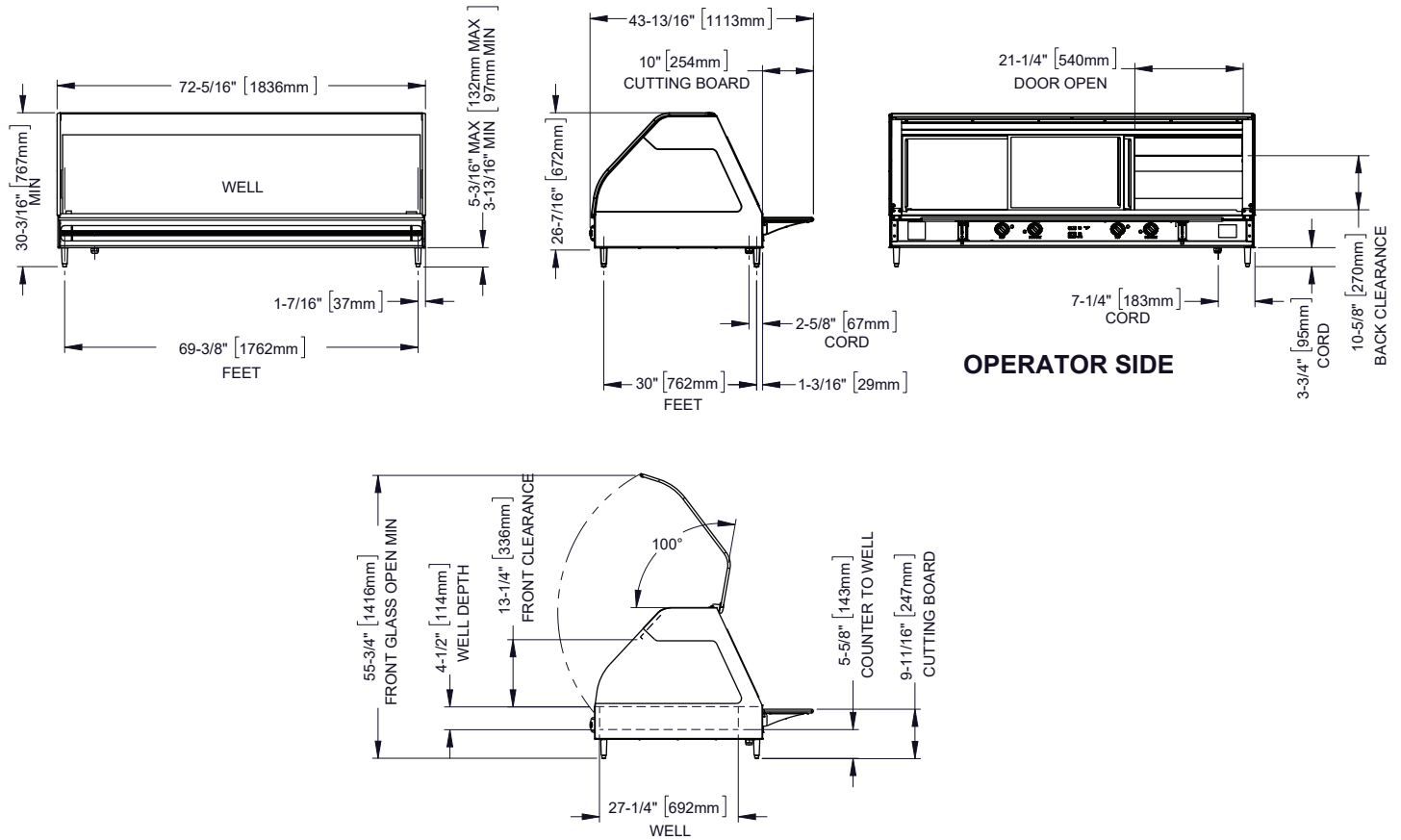

Model
ED3-72
Legs

Exterior (H x W x D)
30-3/16" x 72-5/16" x 43-13/16" [767mm x 1836mm x 1113mm]

Well (W x L x D)
27-1/4" x 69-5/16" x 4-1/2" [692mm x 1761mm x 114mm]

Net Weight
419 lb [190 kg]

Ship Dimensions (H x W x D)*
45" x 85" x 55" [1143mm x 2159mm x 1397mm]

Ship Weight*
465 lb [210 kg]

*Domestic ground shipping information. Contact factory for export weight and dimensions.

ED3-72 Display Case



DIMENSIONS

ED3(SYS)-72 with Stationary Base

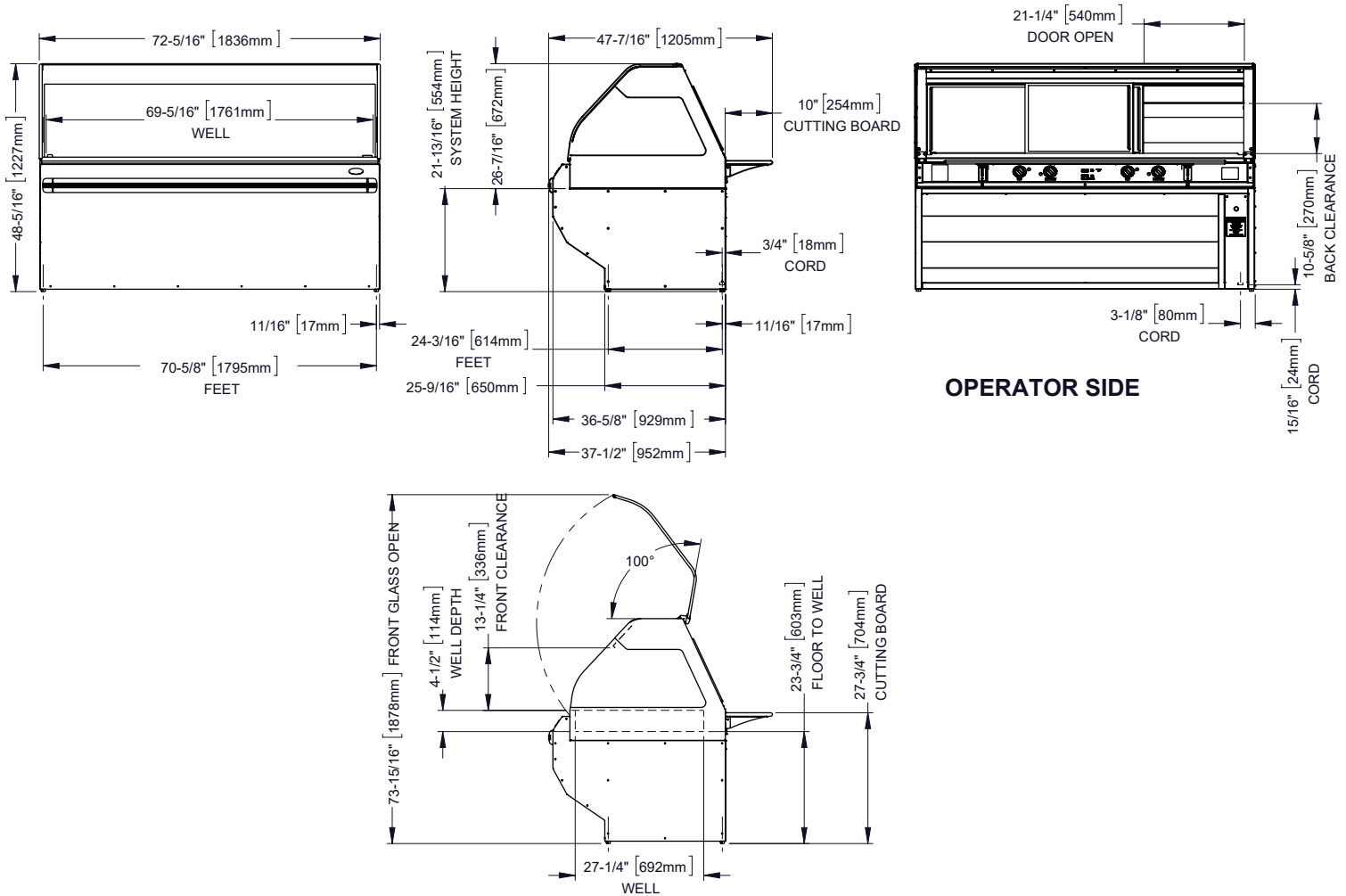

Model

ED3-72
SYS

Exterior (H x W x D)

48-5/16" x 72-5/16" x 47-7/16" [1227mm x 1836mm x 1205mm]

Well (W x L x D)

27-1/4" x 69-5/16" x 4-1/2" [692mm x 1761mm x 114mm]

Net Weight

621 lb [282 kg]

Ship Dimensions (H x W x D)*

65" x 85" x 55" [1651mm x 2159mm x 1397mm]

Ship Weight*

700 lb [317 kg]

*Domestic ground shipping information. Contact factory for export weight and dimensions.

ED3 Pan Configurations

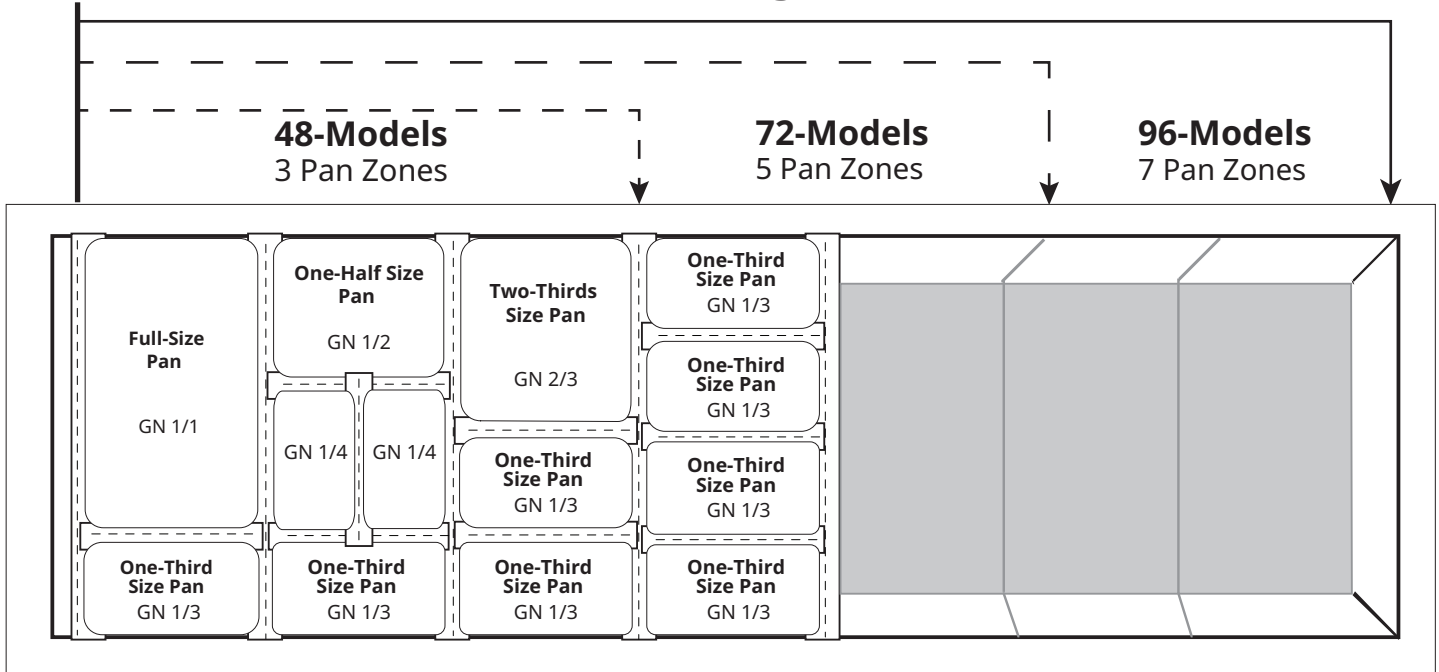

REQUIREMENTS

Installation Requirements

- The display case must be installed level.
- The display case must not be installed in any area where it may be affected by steam, grease, dripping water, high temperatures, or any other severely adverse conditions.
- Do not install a heated display case near a cold air source such as a freezer, air conditioning vents, or in any area where outside air fluctuation can affect performance.



HEAT

Heat of rejection

ED3-96	Heat Gain q _s , BTU/hr	Heat Gain q _s , kW
	456	0.13



72 Series

ED3-72 With feet	V	Ph	Hz	AWG* minimum	A	Breaker minimum	kW	Connection
	208	1	50/60	14	15.0	19A	3.11	6ft; NEMA 6-30 Ⓢ
	240	1	50/60	14	17.2	22A	4.14	6ft; NEMA 6-30 Ⓢ

*Recommended minimum conductor sized at 90°C and ambient 30°C.
Electrical connections must meet all applicable federal, state, and local codes.

ED3-72 With base	V	Ph	Hz	AWG* minimum	A	Breaker minimum	kW	Connection
	208	1	50/60	14	15.0	19 A	3.11	No cord, no plug
	240	1	50/60	14	17.2	22 A	4.14	No cord, no plug

* Recommended minimum conductor sized at 90°C and ambient 30°C.
Electrical connections must meet all applicable federal, state, and local codes.

CONTACT US

W164 N9221 Water Street | Menomonee Falls, Wisconsin 53051 | U.S.A.
Phone: 262.251.3800 | 800.558.8744 U.S.A./Canada | Fax: 262.251.7067 | alto-shaam.com