

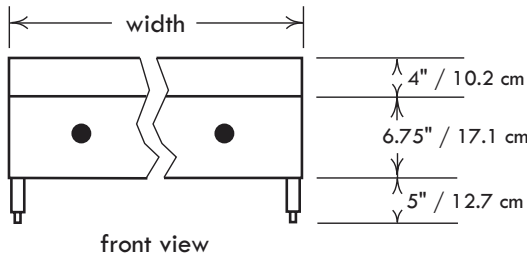

JOB _____ ITEM # _____

GRIDDLES

38 Series: 30" Cook Depth



front view

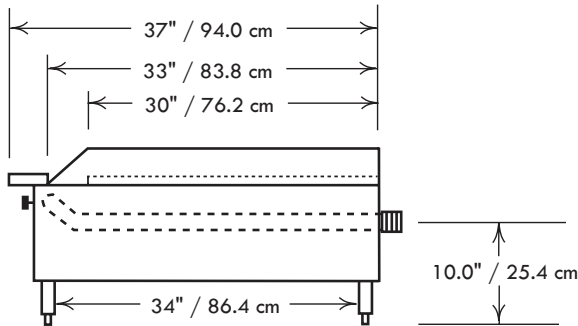

side view



Model 3836MG



Standard Features, Benefits & Options

CONSTRUCTION: Easy cleaning, corrosion resistant stainless steel. Welded frame with insulated side panels. Stainless steel front control panel. 4" wide stainless steel bull nose landing across the front is a functional work area for service plates and work utensils as well as control protection. Installation clearances for non-combustible surfaces are 0" on the sides and 0" in the rear, combustible surfaces are 6" on the sides and 6" in the rear.

GRIDDLEPLATE: 30" deep cooking surface for large volume cooking, 3/4" thick for even efficient heat distribution & fast recovery and highly polished to minimize food sticking. 1" plates also available. 4" high stainless steel splash guard is standard, higher & lower sides are also available. A large drain slot channels grease into the large capacity, seamless grease drawer.

CONTROLS: Equipped with brass gas valves and automatic standing pilots. Pressure regulators are set at the factory for the type of gas specified. Optimal pressures are 4" WC for natural gas & 10" WC for propane. Throttling thermostat controls are available, adjusting from 150F to 450F to provide accurate temperature control to +/- 20F of set point. Manifold size is 3/4" NPT. All controls are tested and confirmed in good working order. Installation, calibration and adjustments are the responsibility of the buyer.

BURNERS: 12" incremental griddles feature 30,000 BTU burners, one for each 12" increment. 18", 30" & 42" models feature 2", 4" & 6" burners respectively, each rated at 18,000 BTU.

OPTIONS & ACCESSORIES: Thermostats, safety pilot controls, chrome griddle surfaces, grooved griddle surfaces, extra tall splash guards, gas hoses, knob protectors, carrying handles, spatulas, scrapers and matching equipment stands.

SPECIFICATIONS

Model Number	Width in./mm.	Sq.in. surface	Total BTU	Approx. kg/lbs
3812MG	12 / 305	360	30,000	68 / 150
3818MG	18 / 458	540	54,000	91 / 200
3818TG	18 / 458	540	54,000	91 / 200
3824MG	24 / 610	720	60,000	136 / 300
3824MG	24 / 610	720	60,000	136 / 300
3830MG	30 / 762	900	72,000	182 / 400
3830TG	30 / 762	900	72,000	182 / 400
3836MG	36 / 914	1080	90,000	227 / 500
3836TG	36 / 914	1080	90,000	227 / 500
3842MG	42 / 1069	1260	108,000	273 / 600
3842TG	42 / 1069	1260	108,000	273 / 600
3848MG	48 / 1219	1440	120,000	318 / 700
3848TG	48 / 1219	1440	120,000	318 / 700
3860MG	60 / 1524	1800	150,000	398 / 875
3860TG	60 / 1524	1800	150,000	398 / 875
3872MG	72 / 1829	2160	180,000	477 / 1050
3872TG	60 / 1829	2160	180,000	477 / 1050



Comstock-CastleStoveCo. • 119W. Washington St. • Quincy, IL 62301
Tel.: 217-223-5070 • Fax: 217-223-0007 • www.castlestove.com

