

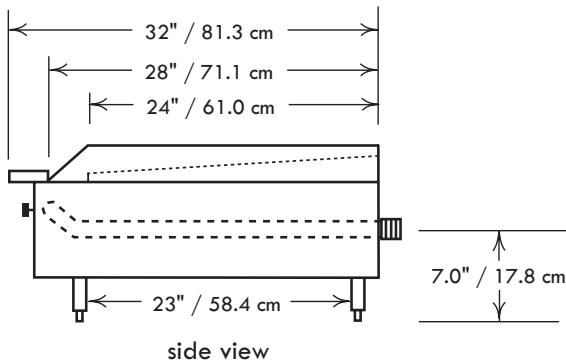

JOB _____ ITEM # _____

CHAR-BROILERS

32 Series: 24" Cook Depth

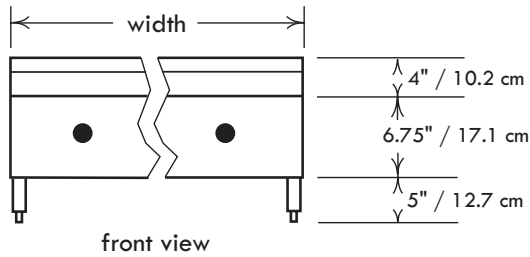

Model 3224RB



Model 3236RB

Standard Features, Benefits & Options

CONSTRUCTION: Easy cleaning, corrosion resistant stainless steel finish, welded with angle iron and aluminized inner framing. Sturdy 5" heavy duty stainless pipe legs with adjustable feet. Stainless steel bullnose-rail is functional on which to set plates or utensils and also serves as control. Corrosion resistant, 16 gauge, welded aluminized steel firebox with excellent heat reflection characteristics. Double wall construction with heavy insulation for cooler operation. Installation clearances for non-combustible surfaces are 0" on the sides and 4" in the rear. Char-broilers are approved for use in non-combustible locations only.

TOP GRATES: Cast iron top grate sections measure 24" deep, designed with cast-in grease trough on each blade to allow grease run off into the front cold zone grease trough and reduces flare up. Each section is reversible for sloped or level grilling. Stainless steel splash guards on 3 sides graduating up to 4" high. Grease drain slot is 3.5" x 1" and feeds into a large, removable grease drawer.

CONTROLS: Equipped with brass gas valves and automatic standing pilots. Pressure regulators are set at the factory for the gas specified. Optimal pressures are 4" WC for natural gas and 10" WC for propane. Manifold size is 3/4" NPT. All controls are tested and confirmed in good working order. Calibration and adjustments are the responsibility of the installer.

BURNERS: 12" incremental char-broilers feature 40,000 BTU burners, one for each 12" increment. 18", 30" and 42" models feature 2, 4 and 6 burners respectively, each rated at 18,000 BTU.

MATCH-UP: 32 Series char-broilers are designed to match up with 32 Series griddles and hotplates.

ACCESSORIES: Safety pilot controls, lava rock, gas hoses, grill scrapers, spatulas, cleaning supplies, carrying handles, knob protectors and matching equipment stands.

SPECIFICATIONS

Model Number	Width in./mm.	Sq.in. surface	Total BTU	Approx. kg/lbs
3212LB	12 / 305	288	30K	68 / 150
3212RB	12 / 305	288	30K	68 / 150
3218LB	18 / 457	432	36K	91 / 200
3218RB	18 / 457	432	36K	91 / 200
3224LB	24 / 610	576	60K	114 / 250
3224RB	24 / 610	576	60K	114 / 250
3230LB	30 / 762	720	72K	137 / 300
3230RB	30 / 762	720	72K	137 / 300
3236LB	36 / 914	864	90K	182 / 400
3236RB	36 / 914	864	90K	182 / 400
3242LB	42 / 1069	1008	108K	218 / 480
3242RB	42 / 1069	1008	108K	218 / 480
3248LB	48 / 1219	1152	120K	250 / 550
3248RB	48 / 1219	1152	120K	250 / 550
3260LB	60 / 1524	1440	150K	305 / 670
3260RB	60 / 1524	1440	150K	305 / 670
3272LB	72 / 1829	1728	180K	364 / 800
3272RB	72 / 1829	1728	180K	364 / 800

NOTICE: In an ongoing effort of product development & improvement, Comstock-Castle reserves the right to change specifications and product design without notice. Such modifications do not entitle the buyer to corresponding changes or replacements for previously purchased equipment.



Comstock-CastleStoveCo. • 119W. Washington St. • Quincy, IL 62301
Tel.: 217-223-5070 • Fax: 217-223-0007 • www.castlestove.com

