



Models:

ED3-48; ED3SYS-48

ED3-72; ED3SYS-72

ED3-96; ED3SYS-96

- Installation
- Operation
- Maintenance

W164 N9221 Water Street • P.O. Box 450
Menomonee Falls, Wisconsin 53052-0450 U.S.A.

PHONE: 262.251.3800 • 800.558.8744 U.S.A. / CANADA
FAX: 262.251.7067 • 800.329.8744 U.S.A. ONLY
www.alto-shaam.com



Consult instructions for operation and use.

Copyright

© Copyright 5/26 by Alto-Shaam, Inc.

All rights reserved.

This manual or any portion thereof may not be reproduced or used in any manner whatsoever without the express written permission of Alto-Shaam, Inc.

Trademarks

All trademarks referenced in this documentation are the property of their respective owners.

Manufacturer

Alto-Shaam, Inc.

P.O. Box 450

W164 N9221 Water Street

Menomonee Falls, WI 53052

Original Instructions

The content in this manual is written in American English.

Service Parts

Interactive parts diagrams for this appliance are available online using our Parts Finder Tool:

<https://www.alto-shaam.com/en/customer-support/parts>.

Or, scan the QR code below.



Warranty and Service Information 2
Delivery 5
Unpacking 6
Safety Precautions 7
Labels 9
Installation 10
Weights 11
Dimensions 12
Electrical Connection 13
Operation 14
Cleaning and Preventative Maintenance 16
Warranty 19

Enjoy your Alto-Shaam Heated Display Case!

Halo Heat® Technology Alto-Shaam heated display cases utilize a controlled, uniform heat source that gently holds and surrounds food for better appearance, taste, and longer holding life. Display cases are environmentally friendly, provide better food quality, reduce food waste, and require no water connections or drains. Holds and displays hot food fresh and moist for hours—without adding water.

Register your Appliance

Register Registering your appliance ensures prompt service in the event of a warranty claim. You will also receive direct notifications of software updates and additional product information. Your personal information will not be shared with any other company.
www.alto-shaam.com/warranty

Alto-Shaam 24/7 Emergency Repair Service

Call Call 800-558-8744 to reach our 24-hour emergency service call center for immediate access to local authorized service agencies outside standard business hours. The emergency service access is provided exclusively for Alto-Shaam equipment and is available throughout the United States through Alto-Shaam's toll free number.

Availability Emergency service access is available seven days a week, including holidays.

This Alto-Shaam appliance has been thoroughly tested and inspected to ensure only the highest quality appliance is provided. Upon receipt, check for any possible shipping damage and report it at once to the delivering carrier.

This appliance, including unattached items and accessories, may be delivered in one or more packages. Ensure all standard items and options have been received with each appliance as ordered. Save all the information packed with the appliance. Register the appliance online at www.alto-shaam.com/en/support/warranty-registration to ensure prompt service in the event of a warranty parts and labor claim.

This manual must be read and understood by all people using or installing the appliance. Contact the Alto-Shaam Tech Team Service Department if you have any questions concerning installation, operation, or maintenance.

1-800-558-8744; servicedept@alto-shaam.com

The serial number is required for all inquiries.

Always include both model and serial number(s) in any correspondence regarding the appliance.

Model: _____

Serial number: _____

Purchased from: _____

Date installed: _____ Voltage: _____

Environmental Conditions

Operational Environmental Conditions

- Before use, appliance must acclimate to room temperature in the environment it is placed — 24 hours is recommended.
- Ambient temperature range of 60°F to 110°F (16°C to 43°C).
- Relative humidity of less than 95% non-condensation.
- Atmospheric pressure range of 17.7" to 31.3" of mercury (50kPa to 106kPa).

Unpacking

- Carefully remove the appliance from the carton or crate.
NOTE: Do not discard the carton and other packaging material until you have inspected the appliance for hidden damage and tested it for proper operation.
- Remove all protective plastic film, packaging materials, and accessories from the appliance before connecting electrical power. Store any accessories in a convenient place for future use.

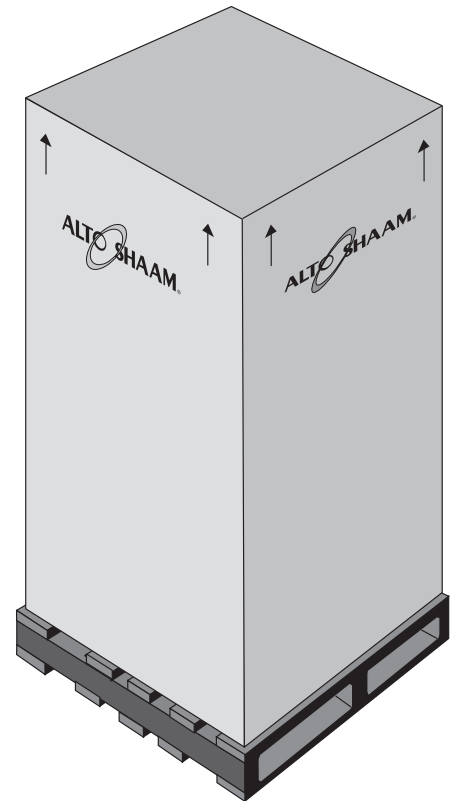

- The appliance is intended to hold hot food for the purpose of human consumption. No other use for this appliance is authorized and is therefore considered dangerous.
- The appliance must not be used to hold food containing flammable materials (such as food with alcohol). Substances with a low flash point can ignite spontaneously and cause a fire.
- The appliance is intended for use in commercial establishments where all operators are familiar with the purpose, limitations, and associated hazards of this appliance. Operating instructions and warnings must be read and understood by all operators and users.
- This appliance is intended to be used for commercial applications, for example in kitchens of restaurants, canteens, hospitals and in commercial enterprises such as bakeries, butcheries, etc., but not for continuous mass production of food.
- The appliance is intended to be used in an area open to the public.
- This appliance is not intended to be used by laymen in household and similar applications such as: staff kitchen areas in shops, offices, and other working environments; farmhouses, hotels, motels and other residential type environments; bed and breakfast type environments.
- Any troubleshooting guides, component views, and parts lists included in this manual are for general reference only and are intended for use by qualified and trained technicians.
- This manual should be considered a permanent part of this appliance. This manual and all supplied instructions, diagrams, schematics, parts lists, notices, and labels must remain with the appliance if the appliance is sold or moved to another location.

The following signal words and symbols may be used throughout this manual.

⚠ DANGER

Indicates a hazardous situation that, if not avoided, will result in death or serious injury.

⚠ WARNING

Indicates a hazardous situation that, if not avoided, could result in death or serious injury.

⚠ CAUTION

Indicates a hazardous situation that, if not avoided, could result in minor or moderate injury.

NOTICE: Indicates information considered important, but not hazard-related (e.g., messages relating to property damage).











NOTICE: For equipment delivered for use in any location regulated by the following directive: 2012/19/EC WEEE

Do not dispose of electrical or electronic equipment with other municipal waste.

Safety Procedures

- To prevent serious injury, death or property damage, the appliance should be inspected and serviced at least every twelve (12) months by an authorized service partner or trained technician.
- **Only** allow an authorized service partner or trained technician to service or to repair the appliance. Installation or repairs that are not performed by an authorized service partner or trained technician, or the use of non-factory authorized parts, will void the warranty and relieve Alto-Shaam of all liability.
- When working on this appliance, observe precautions in the literature, on tags, on labels attached to or shipped with the appliance and other safety precautions that may apply.
- This appliance is not intended for use by persons (including children) with reduced physical, sensory or mental capabilities, or lack of experience and knowledge, unless they have been given supervision concerning use of the appliance by person responsible for their safety.
- Children should be supervised to ensure that they do not play with the appliance.
- Only operate the appliance with pans installed to avoid possible equipment damage.

 <p>WARNING / ADVERTENCIA / AVERTISSEMENT</p> <p>Overhead obstacle hazard. Do not load and unload the display case through the glass hood. Always load and unload the display case from the operator's side.</p> <p>Peligro de obstáculos por encima de la cabeza. No cargue ni descargue la vitrina a través de la campana de cristal. Cargue y descargue la vitrina siempre por el lado del operador.</p> <p>Risque d'obstacle en hauteur. Ne pas charger ni décharger la vitrine par le capot vitré. Toujours le faire par le côté opérateur de la vitrine.</p>	<p>Overhead obstacle hazard.</p> <p>Do not load and unload the display case through the glass hood. Always load and unload the display case from the operator's side.</p>
	<p>WARNING</p> <p>Hot surface</p>
 <p>WARNING/ADVERTENCIA/AVERTISSEMENT</p> <p>Electric Shock Hazard To reduce the risk of electric shock, do not remove or open cover. No user-serviceable parts inside. Refer servicing to qualified personnel. Qualified personnel: Disconnect power before servicing.</p> <p>Peligro de descarga eléctrica Para reducir el riesgo de descarga eléctrica, no retire ni abra la cubierta. No hay piezas en el interior a la que se les pueda realizar mantenimiento. Dirija el mantenimiento a personal cualificado. Personal cualificado: Desconecte la energía antes de realizar mantenimiento.</p> <p>Danger de décharge électrique Pour réduire le risque de décharge électrique, ne parquez ni retirez le capot. Ne consentez pas de travaux réparables par l'utilisateur. Confiez les réparations à du personnel qualifié. Personnel qualifié : Sectionnez l'alimentation avant toute intervention.</p> <p>LA-28592</p>	<p>WARNING</p> <p>Electric shock hazard</p> <p>To reduce the risk of electric shock, do not remove or open cover. No user-serviceable parts inside. Refer servicing to qualified personnel. Qualified personnel: Disconnect power before servicing.</p>
 <p>WARNING ADVERTENCIA AVERTISSEMENT</p> <p>Electric shock hazard. For use on individual branch circuit only.</p> <p>Peligro de descarga eléctrica. Para uso únicamente en circuitos derivados individuales.</p> <p>Danger de décharge électrique. À utiliser uniquement sur un circuit de dérivation individuel.</p> <p>LA-3881</p>	<p>WARNING</p> <p>Electric shock hazard</p> <p>For use on individual branch circuit only.</p>
 <p>WARNING/ADVERTENCIA/AVERTISSEMENT</p> <p>Fire hazard. The underside of the display case may become hot enough to cause a fire during use if installed directly to a countertop. Install the display case on an appropriate base or on legs before operating.</p> <p>Peligro de incendio. La parte inferior de la vitrina puede calentarse lo suficiente como para provocar un incendio durante su uso si se instala directamente sobre una encimera. Instale la vitrina sobre una base adecuada o sobre patas antes de ponerla en funcionamiento.</p> <p>Risque d'incendie. Le dessous de la vitrine peut devenir suffisamment chaud pour provoquer un incendie durant l'utilisation si elle est placée directement sur un comptoir. Installez la vitrine sur un support adapté ou sur des pieds avant de la mettre en service.</p> <p>LA-3882</p>	<p>WARNING</p> <p>Fire hazard</p> <p>The underside of the display case may become hot enough to cause a fire during use if installed directly to a countertop. Install the display case on an appropriate base or on legs before operating.</p>
 <p>LA-4751</p>	<p>Do not add water.</p>
<p>NOTICE / AVIS / AVISO</p> <p>Do not exceed shelf weight limit of 75 lbs (34 kg). Ne dépassez pas la limite de poids des tablettes de 34 kg. No exceda el límite de peso del estante de 34 kg.</p> <p>LA-4721</p>  <p>LA-4727</p>	<p>Do not exceed shelf weight limit of 75 lbs (34 kg).</p>
 <p>WARNING / ADVERTENCIA / AVERTISSEMENT</p> <p>Overhead obstacle hazard. When lifted to the full upright position, the hood glass presents an overhead obstacle. To avoid bodily injury, be mindful of the position of the hood glass when it is open. Have an assistant monitor the hood glass to prevent it from lowering uncontrolled should the stabilizing struts malfunction while the hood glass is in the upright position. Do not raise the hood glass if the stabilizing struts cannot hold it in the upright position.</p> <p>Peligro de obstáculos por encima de la cabeza. Cuando se eleva a la posición totalmente vertical, el cristal de la campana presenta un obstáculo por encima de la cabeza. Para evitar lesiones corporales, presta atención a la posición del cristal de la campana cuando esté abierto. Pídele a un ayudante que vigile el cristal de la campana para evitar que descienda de forma descontrolada, en caso de que los puentes estabilizadores se averíen mientras el cristal de la campana está en posición vertical. No levante el cristal de la campana si los puentes estabilizadores no pueden mantenerlo en posición vertical.</p> <p>Risque d'obstacle en hauteur. Lorsqu'il est complètement relevé, le capot vitré constitue un obstacle en hauteur. Pour éviter les blessures, prenez garde à la position du capot vitré lorsqu'il est ouvert. Veillez à se faire assister par une personne chargée d'empêcher le capot vitré de s'abaisser soudainement en cas de mauvais fonctionnement des vérins de maintien lorsque le capot est relevé. Ne pas relever le capot vitré si les vérins de maintien ne le maintiennent pas en position haute.</p> <p>LA-4861</p>	<p>WARNING</p> <p>Overhead obstacle hazard</p> <p>When lifted to the full upright position, the hood glass presents an overhead obstacle. To avoid bodily injury, be mindful of the position of the hood glass when it is open. Have an assistant monitor the hood glass to prevent it from lowering uncontrolled should the stabilizing struts malfunction while the hood glass is in the upright position. Do not raise the hood glass if the stabilizing struts cannot hold it in the upright position.</p>

CAUTION



Appliance and accessories may be heavy. To prevent serious injury, always use a sufficient number of trained and experienced workers when moving or leveling appliance and handling accessories.

In order to maintain established National Sanitation Foundation standards, all stationary floor models must be sealed to the floor with a R.T.V. or silastic meeting N.S.F. requirements or have 6" (152mm) unobstructed clearance beneath the unit.

- The appliance must be installed on a stable and level surface.
- **DO NOT** install this appliance in any area where it may be affected by any adverse conditions such as steam, grease, dripping water, high temperatures, or any other severely adverse conditions.
- **DO NOT** install a heated display case near a cold air source such as a freezer, air conditioning vents, or in any area where outside air fluctuation can affect performance.
- This appliance must be kept free and clear of any obstructions blocking access for maintenance or service.

Minimum Clearance Requirements

Counter and table units must be mounted on legs of a sufficient 4" (102mm) or 6" (152mm) height depending on unit length to provide minimum unobstructed space beneath the unit. These legs are supplied with the unit. Warranty will become null and void if these directions are not followed.

Leveling

Level the appliance from side-to-side and front-to-back with the use of a spirit level.

It is recommended check the level periodically to ensure the floor has not shifted nor the appliance moved.

NOTICE: Failure to properly level this appliance can cause improper function.

Cutting board installation:

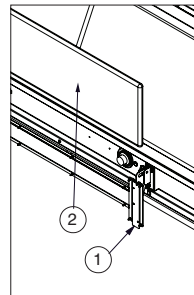

1. Place both brackets in the closed (down) position.
2. Slide cutting board back flanges down onto brackets.
3. Pivot installed board to a horizontal position and slide bracket down to lock in the open position. (NOT SHOWN)

WEIGHT		
Model	Net	Ship
ED3-48	297 lb (135 kg)	372 lb (169 kg)
ED3SYS-48	450 lb (204 kg)	500 lb (227 kg)
Crated dimensions (est.): H x W x D		
ED3-48: 45" x 52" x 45" (1143mm x 1321mm x 1343mm)		
ED3SYS-48: 65" x 60" x 55" (1651mm x 1524mm x 1397mm)		

WEIGHT		
Model	Net	Ship
ED3-72	419 lb (190 kg)	465 lb (210 kg)
ED3SYS-72	621 lb (282 kg)	700 lb (317 kg)
Crated dimensions (est.): H x W x D		
ED3-72: 45" x 85" x 55" (1143mm x 2159mm x 1397mm)		
ED3SYS-72: 65" x 85" x 55" (1651mm x 2159mm x 1397mm)		

WEIGHT		
Model	Net	Ship
ED3-96	526 lb (239 kg)	585 lb (265 kg)
ED3SYS-96	716 lb (325 kg)	796 lb (361 kg)
Crated dimensions (est.): H x W x D		
ED3-96: 45" x 100" x 55" (1143mm x 2540mm x 1397mm)		
ED3SYS-96: 65" x 100" x 55" (1651mm x 2540mm x 1397mm)		

Dimensions

Model ED3-48 Feet	Exterior (H x W x D) 30-3/16" x 48-5/16" x 43-5/8" [767mm x 1227mm x 1108mm]	Well (W x L x D) 27-1/4" x 45-5/16" x 4-1/2" [692mm x 1151mm x 114mm]	Net Weight 297 lb [135 kg]
	Ship Dimensions (H x W x D)* 45" x 52" x 45" [1143mm x 1321mm x 1143mm]	Ship Weight* 372 lb [169 kg]	
		*Domestic ground shipping information. Contact factory for export weight and dimensions.	

Model ED3-48 SYS	Exterior (H x W x D) 48-5/16" x 48-5/16" x 47-7/16" [1227mm x 1227mm x 1204mm]	Well (W x L x D) 27-1/4" x 45-5/16" x 4-1/2" [692mm x 1151mm x 114mm]	Net Weight 450 lb [204 kg]
	Ship Dimensions (H x W x D)* 65" x 60" x 55" [1651mm x 1524mm x 1397mm]	Ship Weight* 500 lb [227 kg]	
		*Domestic ground shipping information. Contact factory for export weight and dimensions.	



Model ED3-72 Legs	Exterior (H x W x D) 30-3/16" x 72-5/16" x 43-13/16" [767mm x 1836mm x 1113mm]	Well (W x L x D) 27-1/4" x 69-5/16" x 4-1/2" [692mm x 1761mm x 114mm]	Net Weight 419 lb [190 kg]
	Ship Dimensions (H x W x D)* 45" x 85" x 55" [1143mm x 2159mm x 1397mm]	Ship Weight* 465 lb [210 kg]	
		*Domestic ground shipping information. Contact factory for export weight and dimensions.	

Model ED3-72 SYS	Exterior (H x W x D) 48-5/16" x 72-5/16" x 47-7/16" [1227mm x 1836mm x 1205mm]	Well (W x L x D) 27-1/4" x 69-5/16" x 4-1/2" [692mm x 1761mm x 114mm]	Net Weight 621 lb [282 kg]
	Ship Dimensions (H x W x D)* 65" x 85" x 55" [1651mm x 2159mm x 1397mm]	Ship Weight* 700 lb [317 kg]	
		*Domestic ground shipping information. Contact factory for export weight and dimensions.	



Model ED3-96 Legs	Exterior (H x W x D) 30-3/16" x 95-15/16" x 43-13/16" [767mm x 2438mm x 1113mm]	Well (W x L x D) 27-1/4" x 93-5/16" x 4-1/2" [692mm x 2370mm x 114mm]	Net Weight 526 lb [239 kg]
	Ship Dimensions (H x W x D)* 45" x 100" x 55" [1143mm x 2540mm x 1397mm]	Ship Weight* 585 lb [265 kg]	
		*Domestic ground shipping information. Contact factory for export weight and dimensions.	

Model ED3-96 SYS	Exterior (H x W x D) 48-3/16" x 95-5/16" x 47-7/16" [1225mm x 2438mm x 1204mm]	Well (W x L x D) 27-1/4" x 93-5/16" x 4-1/2" [692mm x 2370mm x 114mm]	Net Weight 716 lb [325 kg]
	Ship Dimensions (H x W x D)* 65" x 100" x 55" [1651mm x 2540mm x 1397mm]	Ship Weight* 796 lb [361 kg]	
		*Domestic ground shipping information. Contact factory for export weight and dimensions.	





WARNING



Power source must match voltage identified on appliance rating tag. The rating tag provides essential technical information required for any appliance installation, maintenance or repairs. Do not remove, damage or modify the rating tag.

All electrical connections must be made by a qualified and trained service technician in accordance with applicable electrical codes.



WARNING



To prevent serious injury, death, or property damage:

All electrical connections must be made by a qualified and trained service technician in accordance with applicable electrical codes.



This appliance must be adequately grounded in accordance with local electrical codes or, in the absence of local codes, with the current edition of the National Electrical Code ANSI/NFPA No. 70. In Canada, all electrical connections are to be made in accordance with CSA C22.1, Canadian Electrical Code Part 1 or local codes.



CE-approved appliances include an equipotential-bonding terminal marked with the symbol shown on the left.

Provisions for earthing are to be made in accordance with IEC:2010 60335-1 section 27 or local codes.

Plug the unit into a properly grounded receptacle **ONLY**, positioning the unit so that the plug is easily accessible in case of an emergency. Arcing will occur when connecting or disconnecting the unit unless all controls are in the "OFF" position.

Appliances made for international markets

If the unit lacks a flexible cord and plug, incorporate an all-pole disconnection device with at least 4mm² contact separation in the fixed wiring for disconnection. When using a cord without a plug, the green/yellow conductor shall be connected to the terminal marked with the ground symbol. If a plug is used, ensure the socket outlet is easily accessible. For power cord replacement, use an oil resistant cord such as H07RN-F (IEC 2.5mm²) or equivalent.

Hard wired models:

Hard wired models must be equipped with a country certified external allpole disconnection switch with sufficient contact separation.

A tether to restrict movement must be used for appliances that have casters.

NOTICE: Where local codes and CE regulatory requirements apply, appliances must be connected to an electrical circuit that is protected by an external GFCI outlet.

SYS models:

SYS models will have power fed through the grommet at the bottom of the terminal block panel. Remove the screws and panel cover to access the terminal blocks. It should be wired per local codes to the terminal blocks.

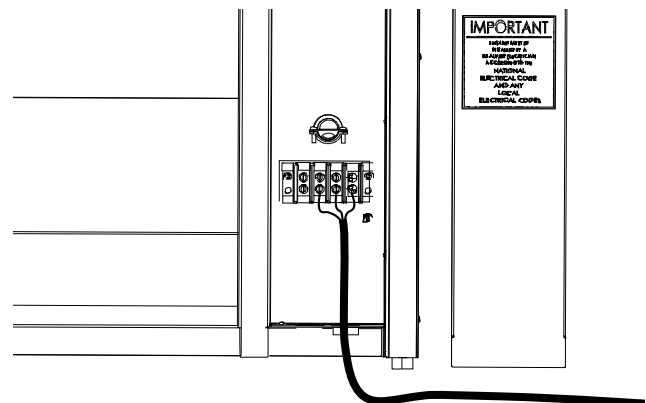

Pan Zones

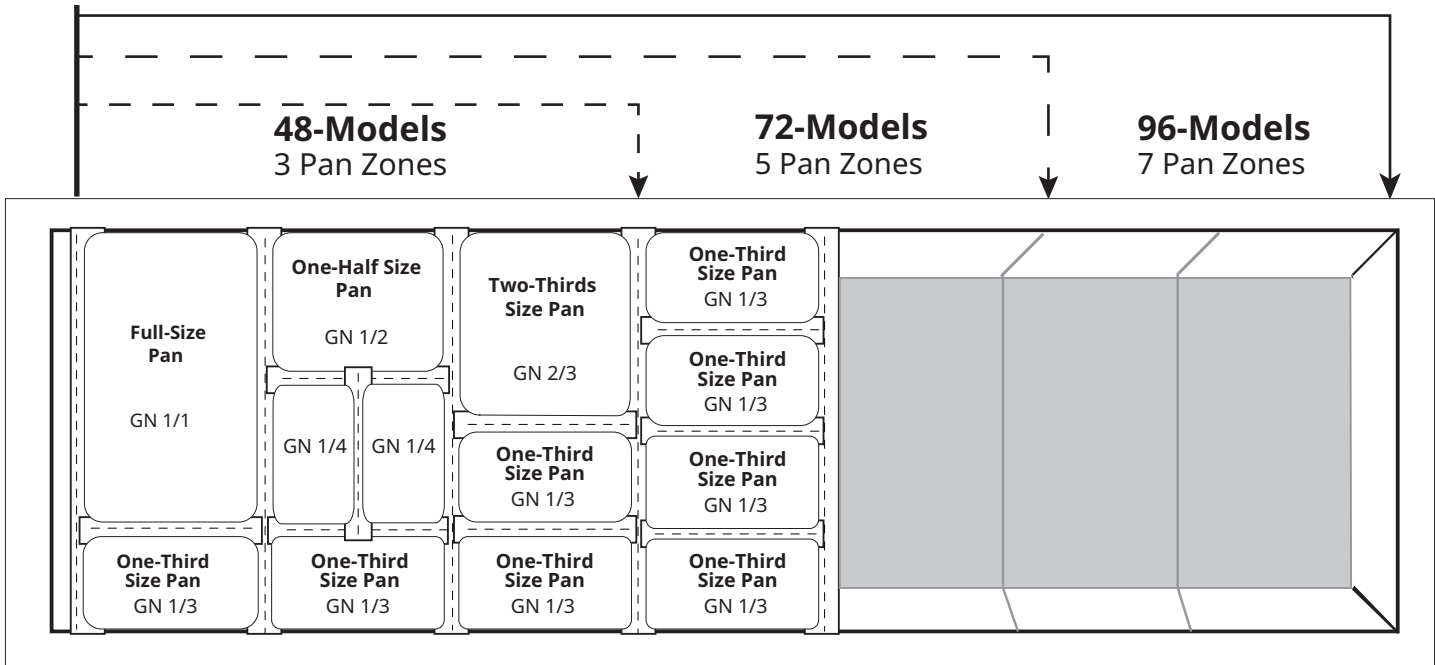

Heat Zones

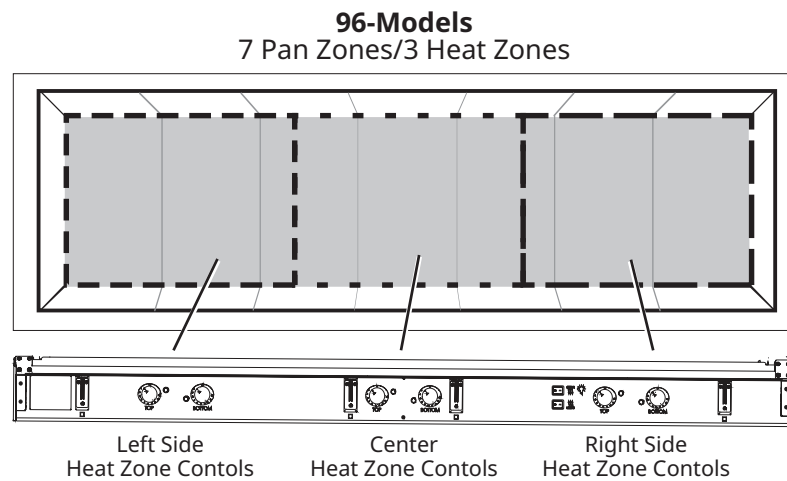
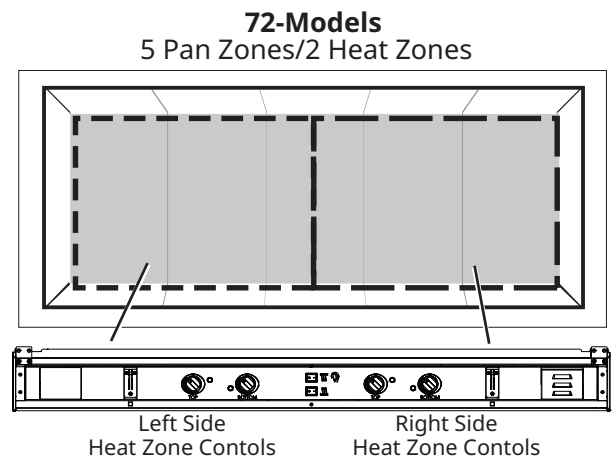
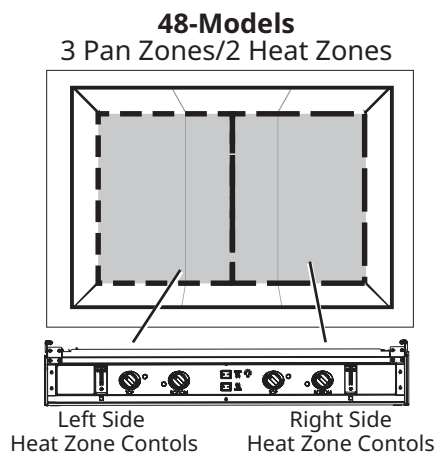

Before Initial Use

Before the initial use of the display case, heat the display case—with pans installed—to burn off any residual surface oils.

To do so:

1. Place dividers and serving pans into the display case.
2. Set the bottom heater switch (1) to the "ON" position.
3. Set bottom thermostats (2) to the "10" setting.
3. Set top thermostats (4) to the "10" setting.
4. Allow the display case to heat for 30 minutes or until no odor is detected.

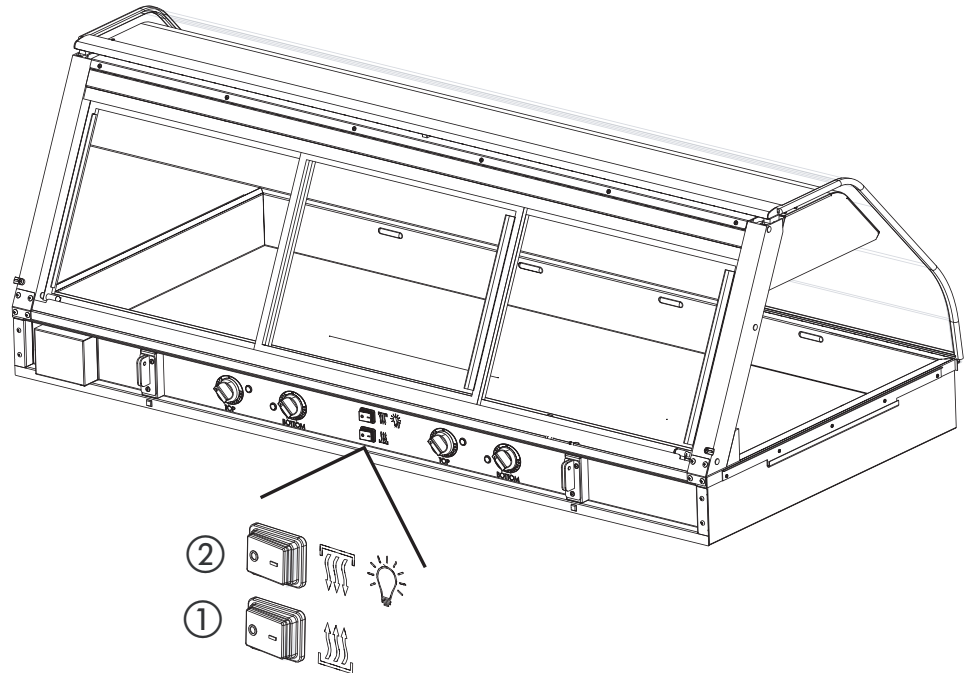

Everyday Use

- Do not add water to the display case.
 - Do not stack food containers.
 - Always use hand protection when loading and unloading the display case.
1. Place dividers and serving pans into the display case.

Note: Refer to the pan layout diagrams for different types of pan combinations.

Be sure to close all gaps between pans and all gaps between pans and the edge of the display case. If these gaps are not closed, heat will escape from the display case. If needed, additional pan divider bars are available.
 2. Set the bottom control switch (1) to the "ON" position.
 3. Set the top control switch (3) to the "ON" position. The top LED lights turn on.
 4. Turn each thermostat to the "5" position. The indicator(s) turn on and will remain on as long as the display case is preheating (calling for heat). Preheat the display case for a minimum of 30–45 minutes before loading hot food into the display case.
 5. Load hot foods into the display case. Be sure only hot food is loaded into the display case. If any food product is not at proper serving temperature, heat it until it is before loading it into the display case.
 6. Adjust the thermostats as needed. Typically, the thermostats do not need to be adjusted if warming the same foods each day. Periodically, use a thermometer to check each item to make sure the correct temperatures are being maintained. Adjust the upper or lower thermostats as necessary.

Preventive Maintenance Schedule

Daily Check List:

- Clean the display case and glass as detailed in this manual.

Monthly Check List:

- Inspect end and front glass pieces for any signs of chips and cracks.
 - Schedule service immediately if a crack or chip is noted.
- Test gas struts (full service cases only).
 - Lift the front glass fully.
 - Ensure glass remains suspended without dropping back down.
 - If struts are not holding the glass in an upright position, schedule service as soon as possible.

Protecting Stainless Steel Surfaces

To care for stainless steel surfaces, avoid harsh chemicals and abrasive tools that can damage the protective layer. Even water, especially hard water with chloride, can cause rust and corrosion. Acidic foods left on surfaces accelerate corrosion. Use proper cleaning agents, materials, and methods. Clean spills promptly and wipe surfaces at least once daily. Rinse thoroughly after cleaning and promptly wipe away standing water.

Cleaning Agents

Use non-abrasive chloride-free cleaning products designed for stainless steel. Never use hydrochloric acid (muriatic acid) on stainless steel surfaces. Failure to observe this precaution will void the warranty. Follow the manufacturer's recommended strength. Contact your local cleaning supplier for product recommendations.

Cleaning Materials

Cleaning typically requires a suitable cleaning agent and a soft, clean cloth. For tougher areas, use a non-abrasive scouring pad with the grain to prevent scratches. Avoid wire brushes, metal scouring pads, or scrapers to remove residue to maintain the warranty.

NOTICE



To protect stainless steel surfaces, completely avoid the use of abrasive cleaning compounds, chloride based cleaners, or cleaners containing quaternary salts. **Never** use hydrochloric acid (muriatic acid) on stainless steel. **Never** use wire brushes, metal scouring pads or scrapers.



⚠ WARNING



To prevent **SERIOUS PERSONAL INJURY, DEATH, or PROPERTY DAMAGE:**

If the appliance is not cleaned or is not cleaned well enough, deposits of grease and/or food residues inside the appliance may catch fire. If fat deposits and/or food waste inside the appliance ignite, disconnect the appliance from the main power and use a fire extinguisher. Do not use water to extinguish a grease fire! Failure to clean the appliance properly may cause fire, personal injury, death, invalidates the warranty and relieves Alto-Shaam of all liability.

WARNING



To prevent serious personal injury, death, or property damage:

Do not steam clean, hose down or flood the interior or exterior with water or liquid solution of any kind. **Do not** use water jet to clean. Failure to observe this precaution will void the warranty.

Cleaning The Probes

If the display case is supplied with probes:

1. Remove all food soil from the probes.
2. Wipe entire probe and cable assembly with warm detergent solution and a clean cloth.
3. Remove detergent by wiping each probe and cable with clean rinse water and a cloth.
4. Wipe probes with disposable alcohol pad or sanitizing solution recommended for food contact surfaces.
5. Allow probe and cable to air dry in probe holding bracket.

Daily Cleaning

Always follow appropriate state or local health (hygiene) regulations regarding all applicable cleaning and sanitation requirements for equipment.

1. Turn lights and adjustable thermostat(s) to the "OFF" position, disconnect unit from power source and let cool.
2. Remove, cover or wrap, and refrigerate food.
3. Clean the interior metal surfaces of the display case with a damp clean cloth or sponge and any good commercial detergent or grease solvent at the recommended strength. Use a plastic scouring pad or oven cleaner for difficult areas. Rinse well to remove all residue and wipe dry.

NOTICE: Never use abrasive cleaning compounds, chloride based cleaners, or cleaners containing quaternary salts. Never use hydrochloric acid (muriatic acid) on stainless steel.

4. Spray heavily soiled areas with a water soluble degreaser and let stand for 10 minutes, then remove soil with a plastic scouring pad.
5. Clean the glass with a window cleaner. The sliding glass doors are removable allowing for easier cleaning.
6. Wipe gaskets, control panel and knobs thoroughly since these areas harbor food debris.
7. Clean the tracks thoroughly to remove build-up of debris.
8. To help maintain the protective film coating on polished stainless steel, clean the exterior of the unit with a cleaner recommended for stainless steel surfaces. Spray the cleaning agent on a clean cloth and wipe with the grain of the stainless steel.

Introduction

Alto-Shaam, Inc. warrants to the original purchaser only, that any original part found to be defective in material or workmanship will be replaced with a new or rebuilt part at Alto-Shaam's option, subject to provisions hereinafter stated.

Warranty Period

The original parts warranty period is as follows:

- For all other original parts, one (1) year from the date of installation of appliance or fifteen (15) months from the shipping date, whichever occurs first.
 - The labor warranty period is one (1) year from the date of installation or fifteen (15) months from the shipping date, whichever occurs first.
 - Alto-Shaam will bear normal labor charges performed during standard business hours, excluding overtime, holiday rates or any additional fees.
 - For the refrigeration compressor, if installed, the warranty period is five (5) years from the date of original installation of the appliance.
 - For heating elements on Halo Heat® Cook and Hold ovens, the warranty period is for as long as the original owner owns the oven. This warranty period applies to units sold after 2/1/2009 and excludes holding-only ovens.
 - To be valid, a warranty claim must be asserted during the applicable warranty period. This warranty is not transferable.
-

Exclusions

This warranty does not apply to:

- Calibration.
 - Replacement of light bulbs, rubber gaskets, grease filters, air filters, racks, jet plates, and/or the replacement of glass due to damage of any kind.
 - Equipment damage caused by accident, shipping, improper installation or alteration.
 - Equipment used under conditions of abuse, misuse, carelessness or abnormal conditions, including but not limited to, equipment subjected to harsh or inappropriate chemicals, including but not limited to, compounds containing chloride or quaternary salts, poor water quality, or equipment with missing or altered serial numbers.
 - Equipment damage caused by use of any cleaning agents other than those recommended by Alto-Shaam, including but not limited to damage due to chlorine or other harmful chemicals.
 - Any losses or damage resulting from malfunction, including loss of food product, revenue, or consequential or incidental damages of any kind.
 - Equipment modified in any manner from original model, substitution of parts other than factory authorized parts, unauthorized removal of any parts including legs, or unauthorized addition of any parts.
 - Equipment damage incurred as a direct result of poor water quality*, inadequate maintenance of steam generators and/or surfaces affected by water. Water quality and required maintenance of steam generating equipment is the responsibility of the owner/operator.
 - Equipment damage incurred as a result of not following the required maintenance schedule published in the manuals for the equipment.
-

Conclusion

This warranty is exclusive and is in lieu of all other warranties, express or implied, including the implied warranties of merchantability and fitness for a particular purpose. No person except an officer of Alto-Shaam, Inc. is authorized to modify this warranty or to incur on behalf of Alto-Shaam any other obligation or liability in connection with Alto-Shaam equipment.

**Refer to the product spec sheet for water quality standards.*

ALTO-SHAAM

Menomonee Falls, WI U.S.A.

Phone 800-558-8744 | +1-262-251-3800 | alto-shaam.com