



Speedino
By **Migali**

PROJECT: _____
 LOCATION: _____
 ITEM#: _____
 QUANTITY: _____

MSP-3848



HIGH PRODUCTION, SMALL FOOTPRINT
 Cooks 95 x 12" Pizzas per hour @ 4 minutes bake time*
 *Bake time will vary depending on ingredients.

CONVEYOR PIZZA OVEN

- Patented innovative balanced air flow system.
- Fast cooking times and highly efficient.
- Extremely quiet operation.
- Compact design, small footprint.
- Made in USA.
- Can be used in single stack or double stack configurations.
- Digital microprocessor controlled bake time and temperature setting.
- Removable crumb trays for easy cleaning.
- Conveyors can run either right-to-left or left-to-right.
- Quality 304 stainless steel construction on major parts.
- Front access to controls.
- Migali Industries® Protection Plan: 5 Year Parts and Labor.

MODEL	BAKING TEMPERATURE	BAKING TIME	RATED HEAT INPUT- NG	RATED HEAT INPUT- LP	SUPPLY INLET PRESSURE	REGULATED PRESSURE	3/4"NPT	PLUG TYPE	VOLTS	AMPS	CORD LENGTH	OVEN DIMENSIONS H X W X D	OVEN WEIGHT	BAKING CHAMBER OPENING H X W X D	BAKING AREA	PACKAGED DIMENSIONS H X W X D	PACKAGED WEIGHT
MSP-3848	300-600°F	2-14 mins	180,085 BTU	180,085 BTU	10-14" WC	9.17" WC	3/4" NPT	NEMA 5-15P	120/60/1	16	6 FT	42.7" x 78.9" x 47.4"	775 LBS	3" x 39" x 48"	13 sq/ft	55" x 55" x 47.5"	990 LBS

NOTE: MIGALI® RESERVES THE RIGHT TO CHANGE SPECIFICATIONS WITHOUT NOTICE

FOR COMMERCIAL USE ONLY



TOLL FREE: 800.852.5292
 WEB: www.migali.com



DIMENSIONAL DRAWINGS

MSP-3848 (Double Stacked)

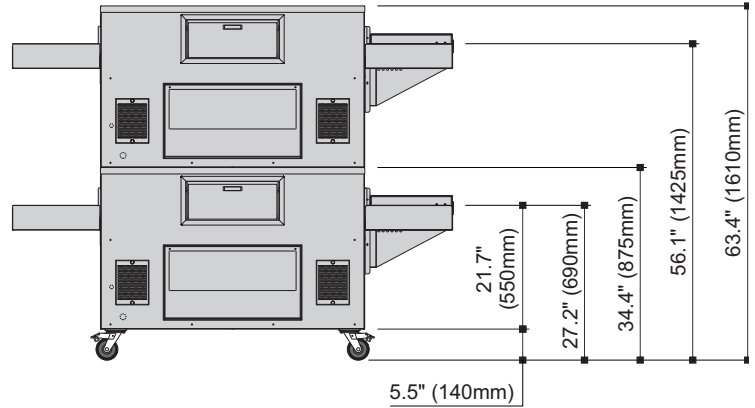
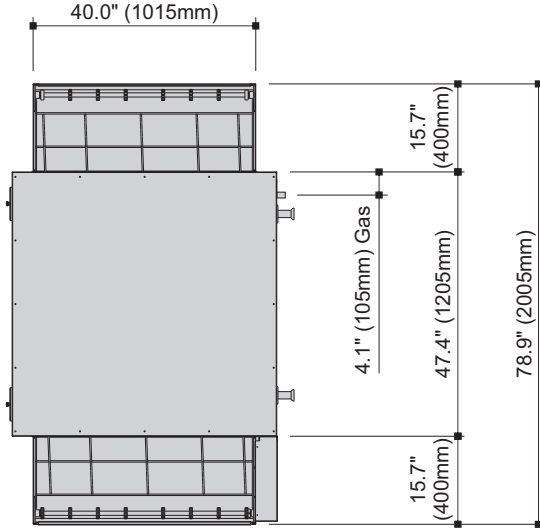

MSP-3848 (Single Stacked)

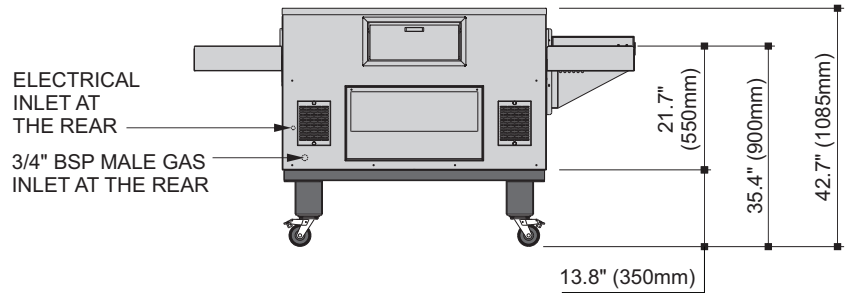
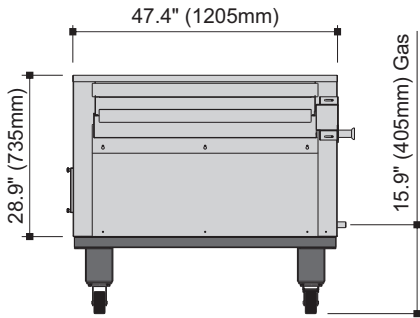

MIGALI® REMAINS AN AMERICAN FAMILY COMPANY SINCE 1955



Speedino
By **Migali**

PROJECT: _____
 LOCATION: _____
 ITEM#: _____
 QUANTITY: _____

MSP-2638



HIGH PRODUCTION, SMALL FOOTPRINT
 Cooks 95 x 12" Pizzas per hour @ 4 minutes bake time*
 *Bake time will vary depending on ingredients.

CONVEYOR PIZZA OVEN

- Patented innovative balanced air flow system.
- Fast cooking times and highly efficient.
- Extremely quiet operation.
- Compact design, small footprint.
- Made in USA.
- Can be used in single stack or double stack configurations.
- Digital microprocessor controlled bake time and temperature setting.
- Removable crumb trays for easy cleaning.
- Conveyors can run either right-to-left or left-to-right.
- Quality 304 stainless steel construction on major parts.
- Front access to controls.
- Migali Industries® Protection Plan: 5 Year Parts and Labor.

MODEL	BAKING TEMPERATURE	BAKING TIME	RATED HEAT INPUT- NG	RATED HEAT INPUT- LP	SUPPLY INLET PRESSURE	REGULATED PRESSURE	3/4" NPT	PLUG TYPE	VOLTS	AMPS	CORD LENGTH	OVEN DIMENSIONS H X W X D	OVEN WEIGHT	BAKING CHAMBER OPENING H X W X D	BAKING AREA	PACKAGED DIMENSIONS H X W X D	PACKAGED WEIGHT
MSP-2638	300-600°F	2-14 mins	156,390 BTU	146,912 BTU	10-14" WC	7.1" WC	3/4" NPT	NEMA 5-15P	120/60/1	10	6 FT	42.7" x 62.4" x 35.4"	550 LBS	3" x 27" x 38"	7 sq/ft	47.5" x 50.5" x 45.5"	715 LBS

NOTE: MIGALI® RESERVES THE RIGHT TO CHANGE SPECIFICATIONS WITHOUT NOTICE

FOR COMMERCIAL USE ONLY



TOLL FREE: 800.852.5292
 WEB: www.migali.com



DIMENSIONAL DRAWINGS

MSP-2638 (Double Stacked)

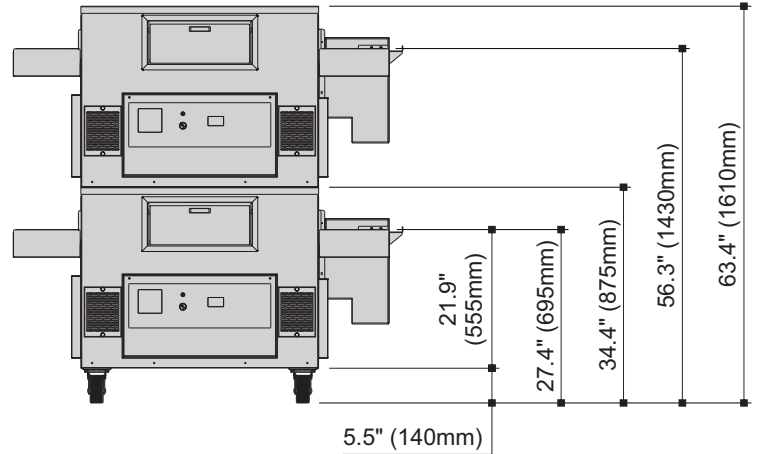
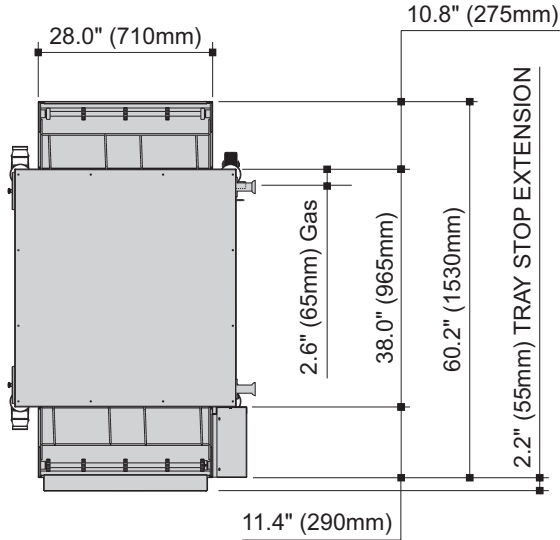

MSP-2638 (Single Stacked)

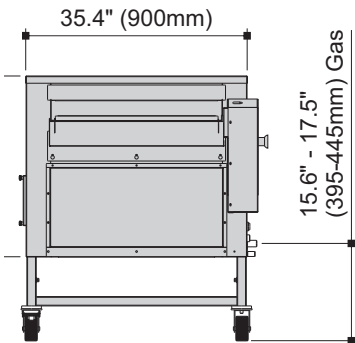

ELECTRICAL INLET AT THE REAR

3/4" BSP MALE GAS INLET AT THE REAR

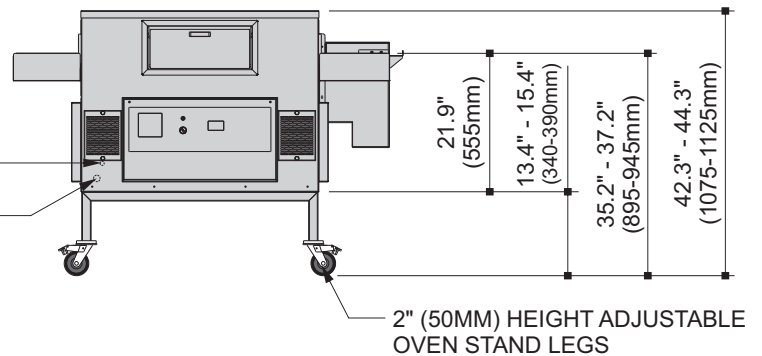

MIGALI® REMAINS AN AMERICAN FAMILY COMPANY SINCE 1955