

Project: _____ Location: _____ Item #: _____ Quantity: _____

Short Specification

Griddle shall be an ENERGY STAR® compliant gas-heated unit, with a hermetically sealed vacuum chamber that produces steam that heats the 7-gauge stainless steel griddle plate. Efficient steam heat transfer provides 200–400°F (93–204°C) operating temperature range and uniform griddle surface temperatures of ±5°F (±3°C). Griddle fabricated from cold-rolled stainless steel with 4" high back splash, sides that taper from 4" to 1 5/16", a 3 7/8" wide by 1/2" deep full front grease trough and 5- 6 1/2 quart grease drawer. Unit to be ANSI Z83.11 Design Certified, UL EPH Sanitation Certified (NSF/ANSI 4) and manufactured in the USA.

Construction Features

- Cold-rolled and annealed stainless steel griddle plate with polished stainless steel body
- 7 gauge griddle plate with 4" high rear splash and 4" to 1 5/16" tapered side walls
- 3 7/8" wide by 1/2" deep full front grease trough
- 1 1/2 x 3 1/2" drop chute to 5 [24"], 6 1/2 [36", 48"] quart capacity grease pan
- 4" legs with bullet feet
- Control guard
- 5' 120v power cord supplied

Performance Features

- Hermetically-sealed steam chamber heats high efficiency griddle plate
- Infrared burners
- Steam transfers heat evenly to entire cooking surface with only ±5°F (±3°C) in temperature variation
- Rapid surface temperature recovery allows turning product to same spot
- Smooth cold-rolled stainless steel griddle surface speeds and simplifies cleaning

Standard Control Features

- Heating indicator light
- 200–400°F (93–204°C) digital thermostat
- Easy front service access to controls
- Control guard
- 3 preset temperatures capable
- Instant surface temperature readout
- Manager mode to lock out temperature controls
- Over temperature indicator light

Cooking Capacity & Applications

Effective Cooking Area

Depth	24" Wide	36" Wide	48" Wide
30"	717 sq. in.	1077 sq. in.	1437 sq. in.
24"	574 sq. in.	862 sq. in.	1150 sq. in.

Griddle Applications include:

- Pancakes, Eggs, Sausage, French Toast
- Burgers, Grilled Onions, Toasted Buns
- Grilled Cheese, Sandwiches
- Fried Potatoes, Fish, Chicken Breasts, Philly Steaks, Liver and MORE

Safety, Sanitation & Environmental



GGF-A36 AccuSteam™
Tabletop Griddle shown

Options & Accessories

- "U" Channel for connecting 2 griddles
- Front mounted prep shelf—8" wide stainless steel
- Condiment Board
- Maritime Package (call for details)
- Correction Package (call for details)
- Chain Package (call for details)
- Heavy duty stainless steel stand with bottom shelf and 5" casters
- Propane available (call for details)

AccuSteam™ Gas Griddle Specifications						
Model #	GGF1201A2450-T1	GGF1201B2450-T1	GGF1201A3650-T1	GGF1201B3650-T1	GGF1201A4850-T1	GGF1201B4850-T1
BTU Firing Rate per Hour	42,300	42,300	70,000	70,000	85,000	85,000
Unit Width (A)	24.25 [616]	24.25 [616]	36.25 [921]	36.25 [921]	48.25 [1226]	48.25 [1226]
Unit/Installation Depth (D)	38.3 [973]	32.3 [820]	38.3 [973]	32.3 [820]	38.3 [973]	32.3 [820]
Cooking Surface Width (B)	23.9 [607]	23.9 [607]	35.9 [912]	35.9 [912]	47.9 [1217]	47.9 [1217]
Cooking Surface Depth (C)	30 [762]	24 [610]	30 [762]	24 [610]	30 [762]	24 [610]
Rear Leg to outside of Flue (E)	12 [305]	6 [152]	12 [305]	6 [152]	12 [305]	6 [152]
Center Left to Right Leg (F)	20 [508]	20 [508]	32 [813]	32 [813]	44 [1118]	44 [1118]
Effective Cooking Area	717 sq. in.	574 sq. in.	1077 sq. in.	862 sq. in.	1437 sq. in.	1150 sq. in.
Grease Pan Capacity	5 qt	5 qt	6 ½ qt	6 ½ qt	6 ½ qt	6 ½ qt
NEMA Plug	5-15	5-15	5-15	5-15	5-15	5-15
Shipping Weight	270 lbs	275 lbs	370 lbs	350 lbs	500 lbs	450 lbs
Shipping Dimensions	30" X 43" X 25"	30" X 43" X 25"	42" X 43" X 25"	42" X 43" X 25"	55" X 43" X 25"	55" X 43" X 25"

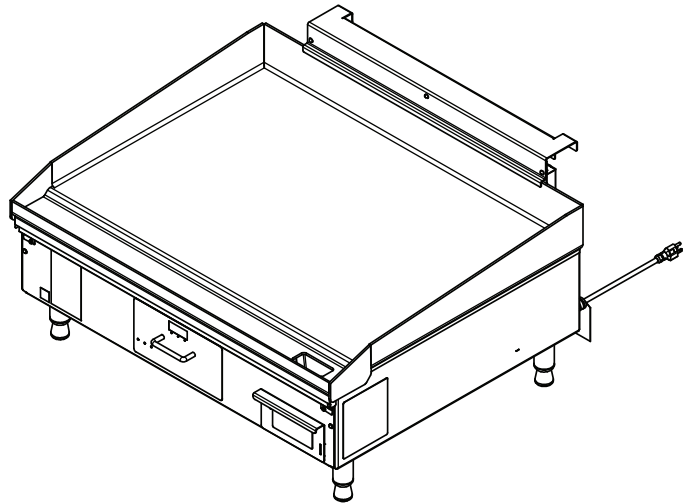
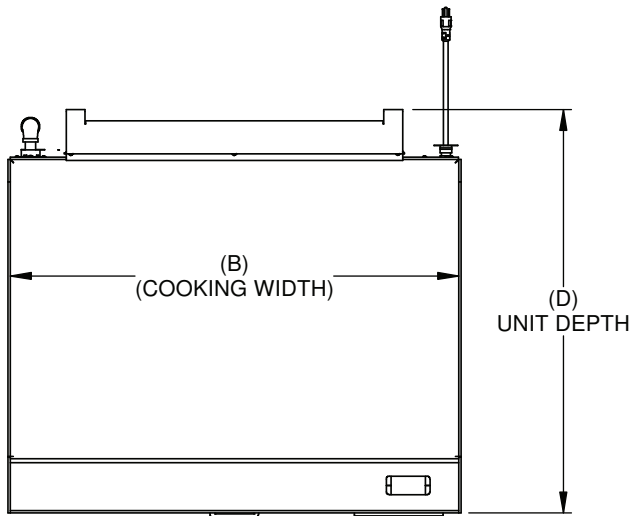

Notes:

- 1.) Dimensions in brackets [] are metric.
- 2.) 3/4" NPT gas connection, 90° elbow provided.
- 3.) 5' 120 volt power cord.
- 4.) Amp draw <3/4A.

