

Project: \_\_\_\_\_ Location: \_\_\_\_\_ Item #: \_\_\_\_\_ Quantity: \_\_\_\_\_

**Standard Features**

- Fast cook times with patented Steam Vector Technology™ (SVT), which utilizes no moving parts
- Cook mode and variable temperature hold mode
- Certified holding cabinet and UL listed
- Easy-to-use digital controls with digital temperature display
- Independent digital electronic timer with programmable preset
- Simple water and drain connections
- No water filtration or treatment required
- No scheduled delimiting
- Cast aluminum heating element is not exposed to water
- No warranty exclusions for water quality
- Uses less than 1 gallon of water per hour
- Easy-to-clean control panel
- Dishwasher-safe one-piece wire pan racks, SVT steam collector and distribution panels, and front-mounted condensate tray
- Operating and cleaning instructions on door
- Front-mounted drain valve
- Heavy-duty, one-piece field reversible door
- Multiple kW heat inputs available for all cooking needs
- Steamer cavity constructed of reinforced 304 stainless steel
- Automatic altitude compensation
- Easy-to-access service panel
- Low water, high water and over-temp indicator lights
- Automatic fill feature
- (2) 5' power cords and plugs included, separate receptacle needed for each steamer
- Stainless steel support stand
- One year parts and labor warranty
- Lifetime Service & Support Guarantee
- EPA 202 evaluated for ventless cooking
- International / Maritime models available; call AccuTemp for more information

**Options & Accessories**

- Bullet feet or flanged feet
- Stainless steel support stand available with casters, bullet feet or flanged feet
- Steam condenser unit (separate power required)
- Drain tempering kit
- 2" Solid hotel pan
- 2" Perforated hotel pan
- Prison package

**Safety, Sanitation & Environmental**

- EPA 202 Evaluated / NFPA 96 4.1.1.2 Compliant
- UL LISTED Safety Certification (UL 197)
- UL EPH Sanitation Certification (NSF 4)



**Pan Capacities**

| Pan Size                    | Qty. |
|-----------------------------|------|
| #200 full size (12x20x2.5") | 9    |
| #400 full size (12x20x4")   | 6    |

**Short Spec**

Evolution™ steamer is AccuTemp Products' electric, connected, boiler-free steamer that utilizes AccuTemp's patented Steam Vector Technology™ for faster cook times, improved energy efficiency, better pan-to-pan uniformity, and less water consumption. Steam Vector Technology utilizes no moving parts inside the cooking chamber. Steam is produced inside the cooking cavity with no heating element exposed to water. Certified holding cabinet. Easily connects to water and drain line. Uses less than 1 gallon of water per hour. Steamer includes low water, high water, over-temp warning lights and auto shut off feature. Evolution includes heavy duty, one-piece field reversible door. Standard digital controls with independent timer. No water quality exclusions in warranty. No water filtration or treatment required. Lifetime Service & Support Guarantee. Steamer is UL Safety and Sanitation Certified, and ENERGY STAR® qualified. Made in the USA.



E3 Evolution™ model shown stacked with E6 Evolution™ model on stand with casters

| Steamer Model "E" Specifications per cavity* DBL = TWO CAVITIES |                      |                      |                      |                      |     |                      |
|---|----------------------|----------------------|----------------------|----------------------|-----|----------------------|
| Model #   | E3/E62081E060<br>DBL | E3/E62083E150<br>DBL | E3/E62401E060<br>DBL | E3/E62403E110<br>DBL |     | E3/E64803E140<br>DBL |
| Volts AC  | 208                  | 208                  | 240                  | 208                  | 240 | 440   480            |
| Phase   | 1                    | 3                    | 1                    | 3                    |     | 3                    |
| Amps  | 29                   | 42                   | 25                   | 22                   | 26  | 16   17              |
| Suggested Breaker Size  | 30 amp               | 50 amp               | 30 amp               | 30 amp               |     | 20 amp               |
| Watts (kW)  | 6                    | 15                   | 6                    | 8                    | 11  | 12   14              |
| NEMA Plug   | L6-30P               | 15-50P               | L6-30P               | L15-30P              |     | L16-20P              |

**Notes:**

1. Allow 3" between fryer, ranges, and other hot surfaces.
2. Each steamer is equipped with a 5' power cord, separate receptacle needed for each steamer.
3. For use on individual branch circuits only.
4. Do not connect to a circuit operating at more than 150V to ground.
5. Steamer dimensions in line drawings are in inches and [millimeters].
6. Each steamer is equipped with 3/4" male garden hose connector for water supply.
7. Each steamer is equipped with 3/4" barbed drain line connector.
8. DO NOT plumb a single drain line between 2 steamers. Each steamer must have a separate drain line.
9. Commercial use only.
10. AccuTemp steamers can be placed on a commercial kitchen countertop or installed on an AccuTemp steamer stand. Do not place directly onto any kind of heat source.

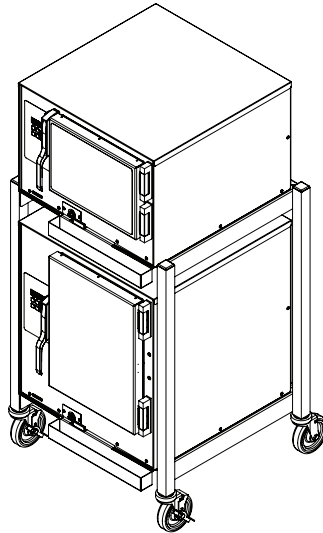
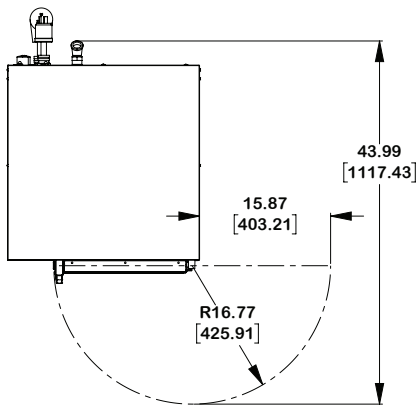

**HEIGHT OF STAND WITH BULLET FEET OR FLANGED FEET:**  
54.88 [1393.95]

