

Project: _____ Location: _____ Item #: _____ Quantity: _____

Standard Features

- Fast cook times with patented Steam Vector Technology™ (SVT), which utilizes no moving parts
- Cook mode and variable temperature hold mode
- Certified holding cabinet and UL listed
- Easy-to-use digital controls with digital temperature display
- Independent digital electronic timer with programmable preset
- Simple water and drain connections
- No water filtration or treatment required
- No scheduled delimiting
- Cast aluminum heating element is not exposed to water
- No warranty exclusions for water quality
- Uses less than 1 gallon of water per hour
- Easy-to-clean control panel
- Dishwasher-safe one-piece wire pan racks, SVT steam collector and distribution panels, and front-mounted condensate tray
- Operating and cleaning instructions on door
- Front-mounted drain valve
- Heavy-duty, one-piece field reversible door
- Multiple kW heat inputs available for all cooking needs
- Steamer cavity constructed of reinforced 304 stainless steel
- Automatic altitude compensation
- Easy-to-access service panel
- Low water, high water and over-temp indicator lights
- Automatic fill feature
- (2) 5' power cords and plugs included, separate receptacle needed for each steamer
- Stainless steel support stand
- One year parts and labor warranty
- Lifetime Service & Support Guarantee
- EPA 202 evaluated for ventless cooking
- International / Maritime models available; call AccuTemp for more information

Options & Accessories

- Bullet feet or flanged feet
- Stainless steel support stand available with casters, bullet feet or flanged feet
- Steam condenser unit (separate power required)
- Drain tempering kit
- 2" Solid hotel pan
- 2" Perforated hotel pan
- Prison package

Safety, Sanitation & Environmental

- EPA 202 Evaluated / NFPA 96 4.1.1.2 Compliant
- UL LISTED Safety Certification (UL 197)
- UL EPH Sanitation Certification (NSF 4)



Pan Capacities

Pan Size	Qty.
#200 full size (12x20x2.5")	12
#400 full size (12x20x4")	8

Short Spec

Evolution™ steamer is AccuTemp Products' electric, connected, boiler-free steamer that utilizes AccuTemp's patented Steam Vector Technology™ for faster cook times, improved energy efficiency, better pan-to-pan uniformity, and less water consumption. Steam Vector Technology utilizes no moving parts inside the cooking chamber. Steam is produced inside the cooking cavity with no heating element exposed to water. Certified holding cabinet. Easily connects to water and drain line. Uses less than 1 gallon of water per hour. Steamer includes low water, high water, over-temp warning lights and auto shut off feature. Evolution includes heavy duty, one-piece field reversible door. Standard digital controls with independent timer. No water quality exclusions in warranty. No water filtration or treatment required. Lifetime Service & Support Guarantee. Steamer is UL Safety and Sanitation Certified, and ENERGY STAR® qualified. Made in the USA.



E6 Evolution™ models shown double-stacked on stand with casters

Steamer Model "E" Specifications per cavity • DBL = TWO CAVITIES							
Model #	E62081E060 DBL	E62083E100 DBL	E62083E150 DBL	E62401E060 DBL	E62403E110 DBL		E64803E140 DBL
Volts AC	208	208	208	240	208	240	440 480
Phase	1	3	3	1	3		3
Amps	29	28	42	25	22	26	16 17
Suggested Breaker Size	30 amp	30 amp	50 amp	30 amp	30 amp		20 amp
Watts (kW)	6	10	15	6	8	11	12 14
NEMA Plug	L6-30P	L15-30P	15-50P	L6-30P	L15-30P		L16-20P

Notes:

1. Allow 3" between fryer, ranges, and other hot surfaces.
2. Each steamer is equipped with a 5' power cord, separate receptacle needed for each steamer.
3. For use on individual branch circuits only.
4. Do not connect to a circuit operating at more than 150V to ground.
5. Steamer dimensions in line drawings are in inches and [millimeters].
6. Each steamer is equipped with 3/4" male garden hose connector for water supply.
7. Each steamer is equipped with 3/4" barbed drain line connector.
8. DO NOT plumb a single drain line between 2 steamers. Each steamer must have a separate drain line.
9. Commercial use only.
10. AccuTemp steamers can be placed on a commercial kitchen countertop or installed on an AccuTemp steamer stand. Do not place directly onto any kind of heat source.

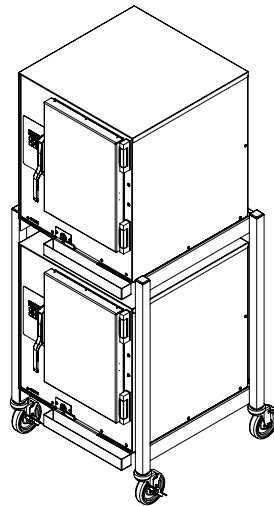
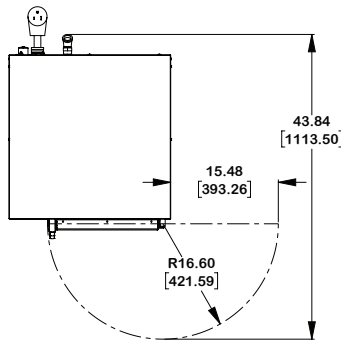

**HEIGHT OF STAND WITH
BULLET FEET OR FLANGED FEET:
64.41 [1636.01]**

