

Project: _____ Location: _____ Item #: _____ Quantity: _____

Standard Features

- Fast cook, low temp, steam, and hold modes
- Super Duty heater configuration
- No water or drain line required
- No hood required (in most areas)
- 3 gallon water reservoir
- Heating element not exposed to water
- No deliming, descaling, or blowdowns
- No water quality exclusions to warranty
- Heavy duty door
- Low water protection with light and buzzer
- Heat, cook, and hold indicator lights
- Fast cook and thermostat mode selector switch
- Vacuum and temperature gauges
- Certified as a variable temperature holding cabinet
- 90 minute timer
- Right hand hinged door
- Quick release door—open door while cooking
- Patented vacuum technology for efficiency & faster cooking
- Continuous cook and hold mode settings on timer
- Power on switch
- Steamer cavity made of durable reinforced 14 ga. 304 stainless steel
- 5' power cord and plug included
- Front mounted drain valve
- Exclusive and patented low temperature steam cooking mode
- Multiple kilowatt outputs available to suit cooking needs
- One year parts and labor warranty
- Lifetime Service and Support Guarantee
- Steam Director covers water for added safety
- Field Reversible Door

Optional Features

- Door hinged on left
- Chain package—factory preset hold temperature; controls behind panel
- Military package
- Corrections package—tamper resistant
- Marine package
- Drain kit
- 4" adjustable bullet feet or flanged feet
- Stainless steel support stand with casters, bullet or flange feet
- Double stacking stand conversion kit
- Steamer door crack open feature
- 4" full size (12x20x4") drain pan
- One year extended warranty



S3 Stand Mounted
Steam&Hold™
Steam Cooker

Safety, Sanitation & Environmental





- EPA 202 Evaluated / NFPA 96 4.1.1.2 Compliant





Pan Capacities

Pan Size	Qty.
#200 full size (12x20x2.5")	3
#400 full size (12x20x4")	2

Short Spec

Steam&Hold™ steamer is AccuTemp Products patented vacuum technology steam cooker with 3 operating modes. Fast cook (212°F), low temperature steam mode (150–200°F) and certified variable temperature hold mode. Steam to be produced inside the cooking cavity with no heating element exposed to water. No water or drain line required. Unit to include heavy duty door, which will open at any time during cooking cycle. Steamer to include low water indicator light and buzzer with auto shutdown feature. Unit to be UL, CE, and ENERGY STAR® qualified. Built in the USA.

Steamer Model "D" Specifications						
Model #	S32081D060 SGL	S32401D060 SGL	S32083D100 SGL	S32403D110 SGL	S34403D090 SGL	S34803D110 SGL
Volts AC	208	240	208	208 240	440	480
Phase	1	1	3	3	3	3
Amps	29	25	28	22 26	12	13
Breaker Size	30 amp	30 amp	30 amp	30 amp	20 amp	20 amp
Watts	6kW	6kW	10kW	8kW 11kW	9kW	11kW
NEMA Plug	L6-30P	L6-30P	L15-30P	L15-30P	L16-20P	L16-20P

Shipping Weight	Shipping Dimensions
208 lbs	32" x 36" x 71"

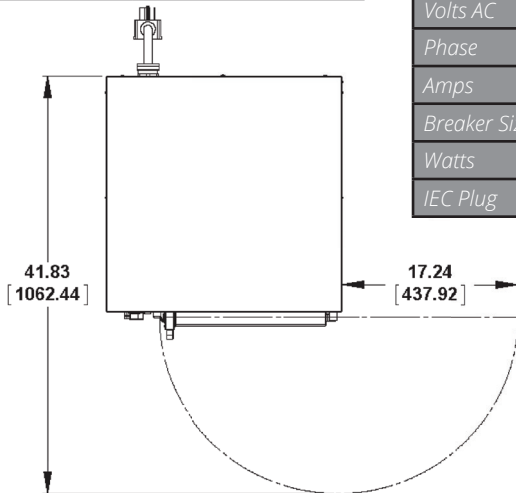

Steamer Model "F" Specifications - CE Models ONLY				
Model #	S32301F070	S34005F110		
Volts AC	230	380	400	415
Phase	1	3	3	3
Amps	32	14	14	15
Breaker Size	40 amp	20 amp	20 amp	20 amp
Watts	7kW	9kW	10kW	11kW
IEC Plug	60309-2 2P/3W/6H 220-250V	60309-2 3P/5W/6H 220/380-240/415V		

Notes:

1. Allow 3" between fryer, ranges, and other hot surfaces.
2. 5' power cord supplied with single or 3 phase.
3. For use on individual branch circuit only.
4. Do not connect to a circuit operating at more than 150V to ground.
5. Dimensions outside brackets are inches, in brackets are millimeters.

