



TOWN

FOOD SERVICE EQUIPMENT CO., INC.



Item Number _____

Project _____

Quantity _____

 800/221.5032
 718/388.5650
  718/388.5860
  customerservice@townfood.com
  townfood.com

MasterRange Junior



Model: M-1-JR-*-#

- Replace * with "N" for natural gas units and "P" for propane gas units
- Replace # with "13" for a 13 inch chamber and "16" for a 16 inch chamber

General

High-performance for small spaces. Despite its small size, the MasterRange Junior utilizes any of the standard burners at their rated capacity. It is intended for applications requiring maximum cooking power, in minimal space. FOR COMMERCIAL-USE ONLY.

Standard Features

- Safety-control included
- Automatic swing faucet, mounted on 12" high backsplash
- Fitted with cast iron chamber-ring , and strainer basket in gutter
- Refractory brick-lined chamber
- Mounted on adjustable legs, with undershelf
- Stainless steel construction

Options

- Available with a 13" chamber or 16" chamber
- Burner options below

Burners: BTU Inputs

Rated at: 6" W.C. Natural 10" W.C. Propane

Burner Type	BTU, Natural	BTU, Propane
Two-ring _____	75,000	58,000
Three-ring ¹ _____	137,000	120,000
23-tip Jet _____	90,000	92,000
32-tip Jet ¹ _____	116,000	103,000
18-tip Vertical Shield _____	97,000	62,000
High Input/Blanch _____	50,000	50,000
18-tip Angle Shield ¹ _____	90,000	80,000
16-tip Volcano _____	75,000	53,000
9-tip No-Clog _____	62,000	44,000
12-tip No-Clog _____	80,000	53,000
Warming chamber _____	15,300	13,200

¹For chambers 16" and larger.

Notify factory if altitude is 2000' or greater above sea level. Please note altitude.



STANDARD DIMENSIONS AND TECHNICAL DATA



MASTERRANGE

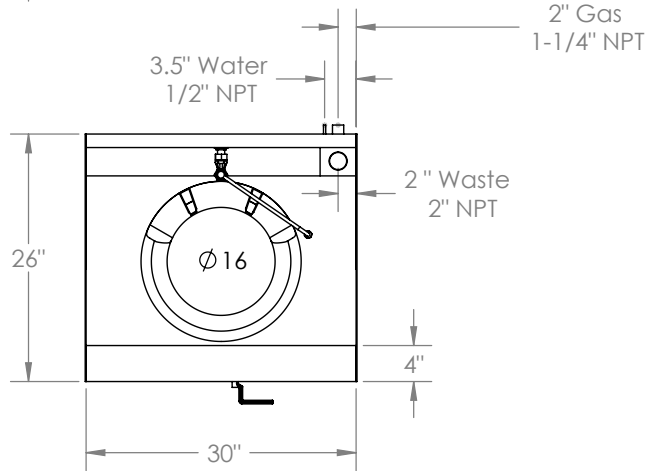
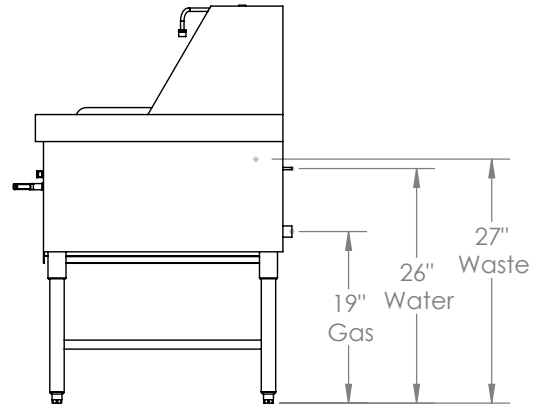
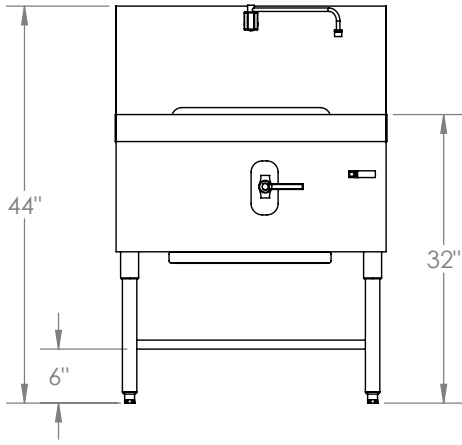

TECHNICAL DATA						
MODEL NO.	DEPTH	WIDTH	HEIGHT ²	SHIP WEIGHT	GAS CONNECTION	MBTUH
M-1-JR-N/P ¹	26"	30"	32"	500 lb.	1 1/4" ³	VARIES BY BURNER

¹ please specify type of gas, N: natural, P: propane
² 44" to the top of the backsplash
³ requires 1 1/4" gas, 1 1/2" waste, and 1/2" cold water

IMPORTANT

Commercial gas range(s) must be installed in accordance with state and local codes, or in the absence of local code with the NATIONAL FUEL GAS CODE- ANSI Z223.1. COMPLIANCE WITH ALL CODES IS THE RESPONSIBILITY OF THE OWNER, AND THE INSTALLER.

COMMERCIAL GAS UNITS NEED ADEQUATE VENTILATION SYSTEMS. REFER TO *National Fire Protection Association Standard No. 96- "Vapor Removal from Cooking Equipment"*

CERTIFIED BY ETL TO CONFORM TO ANSI Z83.11- "GAS FOODSERVICE EQUIPMENT." Not intended for household use. For use by professionally-trained personnel only.

CERTIFIED BY ETL/NSF TO NSF-4/ANSI-4-COMMERCIAL COOKING, RETHERMALIZATION AND HOT FOOD EQUIPMENT- "SANITATION."

MINIMUM CLEARANCES- COMBUSTIBLE AND NON-COMBUSTIBLE:
 Back Wall- 6" Left and Right Sides- 6". For use on non-combustible floors only.

TOWN RESERVES THE RIGHT TO CHANGE DESIGN WITHOUT NOTIFICATION.



TOWN

Town Food Service Equipment Co., Inc.

FOOD SERVICE EQUIPMENT CO., INC.



800/221.5032
718/388.5650



718/388.5860



customerservice@townfood.com



townfood.com