

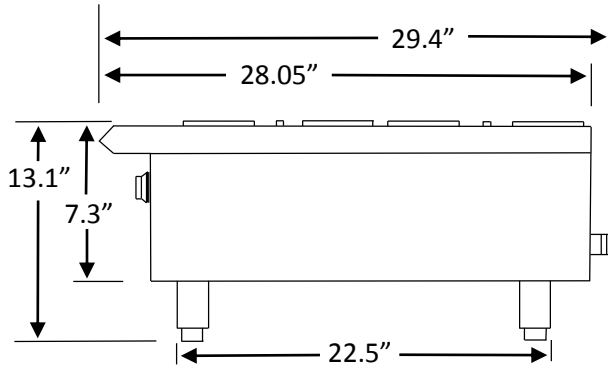

HOT-PLATES

New Value - HP Series

12", 24" & 36" widths; 2, 4 & 6 burners



Model HP24

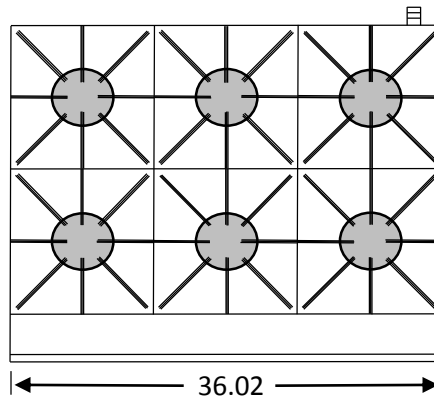
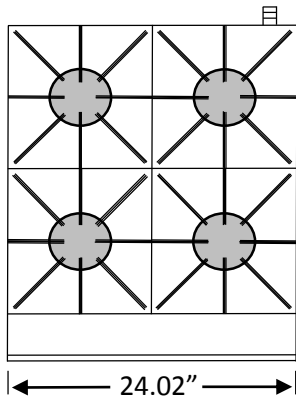
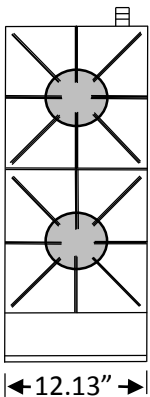

Standard Features, Benefits & Options

CONSTRUCTION: 12", 24" & 36" wide models available. Easy cleaning, corrosion resistant stainless steel finish. Double wall construction, insulated for energy efficiency. 5¼" bull-nose landing. 4" tall adjustable legs. Stainless steel over-flow spill tray.

CONTROLS: Castle griddles are equipped with brass gas valves, front accessible automatic standing pilots, pressure regulators and cool to the touch control knobs with securing set screws.

BURNERS: Efficient cast iron "hex" burners are rated at 25,000 BTU's each provide even heating across the cooking surface.

TOP GRATES: Heavy 12 x 12" wide cast iron top grates designed to slide pots easily across the cook-top.

TESTING: Optimal pressure is 5" WC for natural gas, 10" WC for propane. ETL design & ETL Sanitation (ANSI-NSF4) certified.

Model #	Width x Depth		Burners Total BTU	Ship Wgt.	
	in.	mm		lbs.	kg.
HP12	12.13"	308	2	86	39
	x 29.4"	X 747	----- 50,000		
HP24	24.02"	910	4	168	76
	x 29.4"	X 747	----- 100,000		
HP36	36.02"	915	6	243	110
	x 29.4"	X 747	----- 150,000		



Comstock-Castle Stove Co. • 119 W. Washington St. • Quincy, IL. 62301
Tel.: 217-223-5070 • Fax.: 217-223-0007 • Web: www.castlestove.com

