

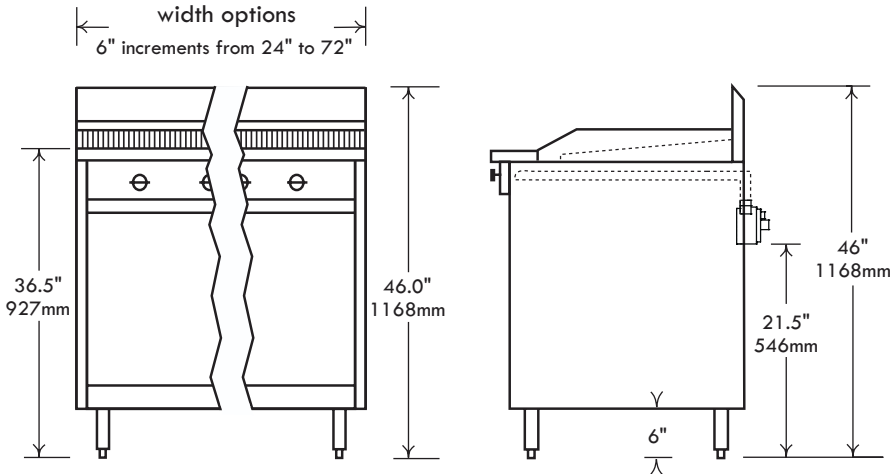

JOB _____ ITEM # _____

FLOOR MODEL CHAR-BROILERS



Model F33-3RB
(shown with optional doors & cutting board)



Standard Features, Benefits & Options

CONSTRUCTION: Easy cleaning, corrosion resistant stainless steel finish, welded with angle iron and aluminized inner framing. Sturdy 4" heavy duty stainless pipe legs with adjustable feet. Stainless steel bullnose-rail is functional on which to set plates or utensils and also serves as control. Corrosion resistant, 16 gauge, welded aluminized steel firebox with excellent heat reflection characteristics. Double wall construction with heavy insulation for cooler operation. Installation clearances for non-combustible surfaces are 0" on the sides and 4" in the rear. Char-broilers are approved for use in non-combustible locations only.

TOP GRATES: Cast iron top grate sections measure 20.5" deep, designed with cast-in grease trough on each blade to allow grease run off into the front cold zone grease trough and reduces flare up. Each section is reversible for sloped or level grilling. Stainless steel splash guards on 3 sides graduating up to 4" high. Grease drain slot is 3.5" x 1" and feeds into a large, removable grease drawer.

BURNERS: 12" incremental broilers feature 25,000 BTU cast iron "H" pattern burners, one for each 12" increment. 18", 30", 42", 54" & 66" models feature 2, 4, 6, 8 & 10 straight burners respectively, each rated at 20,000 BTU's. Optional 35,000 BTU burners available.

RADIANTS: Char-broiler radiants are either lava rock or heavy duty angle iron, inverted "V" type for superior uniform heating temperature. "V" type radiants are easily removable for cleaning.

CONTROLS: Equipped with brass gas valves and automatic standing pilots. Pressure regulators are set at the factory for the gas specified. Optimal pressures are 4" WC for natural gas and 10" WC for propane. Manifold size is 3/4" NPT. All controls are tested and confirmed in good working order. Calibration and adjustments are the responsibility of the installer.

ACCESSORIES: Doors, cutting boards, safety pilots, taller splash guards, lava rock, grate scrapers, spatulas, cleaning supplies, gas hoses, carrying handles, knob protectors.

SPECIFICATIONS

Model Number	Broiler Type	Width in./mm.	Total BTU	Approx. kg/lbs
F32-2LB	Lava	24/610	50K	127 / 280
F32-2RB	Radiant	24/610	50K	127 / 280
F26-2.5LB	Lava	30/762	80K	170 / 375
F26-2.5RB	Radiant	30/762	80K	125 / 275
F33-3LB	Lava	36/914	75K	195 / 430
F33-3RB	Radiant	36/914	75K	195 / 430
F34-4LB	Lava	48/1219	100K	298 / 655
F34-4RB	Radiant	48/1219	100K	164 / 360
F3332-5LB	Lava	60/1524	125K	355 / 780
F3332-5RB	Radiant	60/1524	125K	355 / 780
F3333-6LB	Lava	72/1829	150K	436 / 960
F3333-6RB	Radiant	72/1829	150K	436 / 960



Comstock-CastleStoveCo. • 119W. Washington St. • Quincy, IL. 62301
Tel.: 217-223-5070 • Fax: 217-223-0007 • www.castlestove.com

