



JOB \_\_\_\_\_ ITEM # \_\_\_\_\_

# 48" WIDE RANGES

Base Model: F3430, F3218, F31832



Model F3430-24-1RB



Model F3218

## Standard Features, Benefits & Options

**OVENS:** Large oven measures 31.5" w x 22" d x 14" h for superior baking characteristics and results. Small ovens measure 19.5" w x 22" d x 14" h. Heavy insulation for fuel efficiency. Easy cleaning porcelain and aluminized linings with one nickel plated rack. 3 rack positions with 2 3/4" between rack positions. Large oven features long life, 30,000 BTU cast iron "H" pattern oven burner. Small ovens are rated at 25,000 BTU. Special "V" shaped baffle directs heat for excellent air circulation.

**COOK TOPS:** 24,000 BTU "star" pattern top burners with no gaskets to leak. The large 7" flame spread offers a more efficient burn pattern for small to large pots. Full width crumb trays catch all spillage. Top grates are 12" x 12" cast iron with spillover bowl that also reflects heat for added efficiency. Designed for easy movement of pots across top sections. Stainless steel bullnose-rail is safely flush with the cook tops and functional to straddle pots, skillets and plates and also serves as control protection.

**CONSTRUCTION:** Easy cleaning, corrosion resistant stainless steel finish, welded with angle iron and aluminized inner framing. Sturdy 6" heavy duty stainless pipe legs with adjustable feet. Double wall construction with heavy insulation for cooler operation. Installation clearances for non-combustible surfaces are 0" on sides and 0" in the rear, combustible surface clearances are 2" and 2".

**CONTROLS:** Includes 500° thermostat, 100% safety shut off, automatic standing pilot and brass top burner valves. Pressure regulators are set at the factory for the gas specified. Optimal pressures are 4" WC for natural gas and 10" WC for propane. Manifold size is 3/4" NPT. All controls are tested and confirmed in good working order. Calibration and adjustments are the responsibility of the buyer.

**GRIDDLEPLATES:** 12" increments have 20,000 BTU cast iron burners replacing front to back open burner pairs. 18" & 30" sections feature 2 & 4 "T" burners respectively, rated at 18,000 BTU each, available only when matched together with 18" or 30" char-broilers. 3/4" thick is standard. SS splash guards tapering to 4". Front grease trough and large capacity grease catch. Optional raised griddle-cheesemelters with rear trough are available up to 36". Maximum rack clearance is 4 1/2".

**CHAR-BROILERS:** 12" increments have 25,000 BTU cast iron burners replacing front to back open burner pairs. 18" & 30" sections feature 2 & 4 "T" burners respectively, rated at 20,000 BTU each, available only when matched together with 18" or 30" griddles. Flare up reducing cast iron top grates and radiants for superior heat retention. Front grease trough and large capacity grease catch. SS splash guards tapering to 4". Char-broilers are approved for use in non-combustible locations only.

**HOT TOPS:** Available in 12" width increments in lieu of open top burners. 3/4" thick to hold heat from long life, even heating 20,000 BTU cast iron "H" pattern burners.

**ACCESSORIES & OPTIONS:** Convection fan, casters, extra racks, pizza decks, FD oven thermostats, oven spark pilots, chrome griddle plates, 1" thick griddle plates, griddle thermostats, safety pilot griddles, lift off griddles, grill scrapers, cleaning supplies, hose and quick disconnects, control protection bars, storage base in lieu of oven and low backs are some of the standard options and accessories available.



Comstock-CastleStoveCo. • 119W. Washington St. • Quincy, IL. 62301



Tel.: 217-223-5070 • Fax: 217-223-0007 • www.castlestove.com

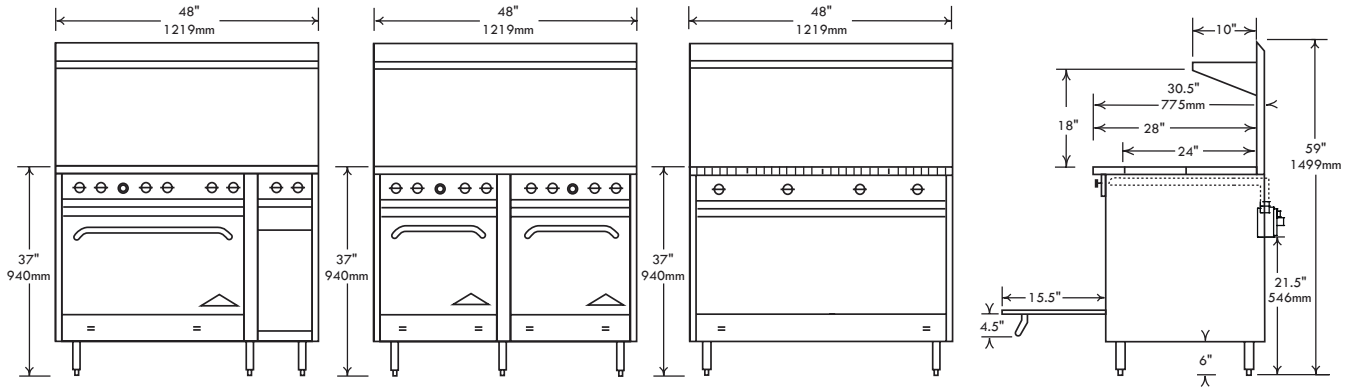

# 48" RANGES MEASUREMENTS

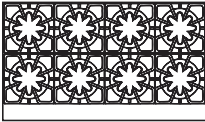
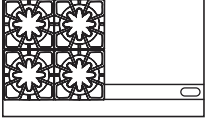
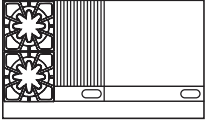

**48" Ranges** (Popular models shown below. Call factory for other model details.)

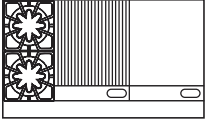
Cooktop Configuration	Model#	Description	Base	Total B.T.U.	Approx. Wgt. Kg./Lbs.
	F3218	(8) Open Burners	- w/ (2) 19.5" Ovens	242,000	295 / 650
	F3430	(8) Open Burners	- w/ (1) 31.5" Oven & 10" storage space	222,000	286 / 630
 <p>*not ETL design listed</p>	F3218-24	(4) Open Burners & (1) 24" Griddle	- w/ (2) 19.5" Ovens	186,000	323 / 710
	F3430-24	(4) Open Burners & (1) 24" Griddle	- w/ (1) 31.5" Oven & 10" storage space	166,000	320 / 705
	F3430-24B*	(4) Open Burners & (1) 24" Griddle, 18" cheesemelter	- w/ (1) 31.5" Oven & 10" storage space	156,000	320 / 705
	F31832-24B	(4) Open Burners & (1) 24" Griddle, 18" cheesemelter	- w/ (1) 19.5" Oven & 21" storage space	151,000	307 / 675
	F3218-24B	(4) Open Burners & (1) 24" Griddle, 18" cheesemelter	- w/ (2) 19.5" Ovens	176,000	327 / 720
	F3218-24-1RB	(2) Open Burners & (1) 24" Griddle & (1) 12" Radiant Broiler	- w/ (2) 19.5" Ovens	143,000	352 / 775
	F3430-24-1RB	(2) Open Burners & (1) 24" Griddle & (1) 12" Radiant Broiler	- w/ (1) 31.5" Oven & 10" storage space	123,000	336 / 740
 <p>*not ETL design listed</p>	F3218-36	(2) Open Burners & (1) 36" Griddle	- w/ (2) 19.5" Ovens	158,000	352 / 775
	F3430-36	(2) Open Burners & (1) 36" Griddle	- w/ (1) 31.5" Oven & 10" storage space	138,000	336 / 740
	F31832-36B	(2) Open Burners & (1) 36" Griddle, 18" cheesemelter	- w/ (1) 19.5" Oven & 21" storage space	123,000	334 / 735
	F3430-36B*	(2) Open Burners & (1) 36" Griddle, 30" cheesemelter	- w/ (1) 31.5" Oven & 10" storage space	138,000	336 / 740
F3218-36B*	(2) Open Burners & (1) 36" Griddle, 30" cheesemelter	- w/ (2) 19.5" Ovens	158,000	355 / 780	
	F3218-18-1.5RB	(2) Open Burners & (1) 18" Griddle & (1) 18" Radiant Broiler	- w/ (2) 19.5" Ovens	174,000	327 / 720
	F3430-18-1.5RB	(2) Open Burners & (1) 18" Griddle & (1) 18" Radiant Broiler	- w/ (1) 31.5" Oven & 10" storage space	154,000	327 / 720

Top sections in lieu of open top burners are located on the right when viewing from the front. Special locations may require custom work and pricing, please call for details. Approximate Packaging Dimensions: 55" (1397mm) Wide x 41" (1041mm) Deep x 40" (1016mm) High.

NOTICE: In an ongoing effort of product development & improvement, Comstock-Castle reserves the right to change specifications and product design without notice. Such modifications do not entitle the buyer to corresponding changes or replacements for previously purchased equipment.