

Model # F3430-36

48" WIDE RANGES



Model F3430-36

*Picture shown with optional casters

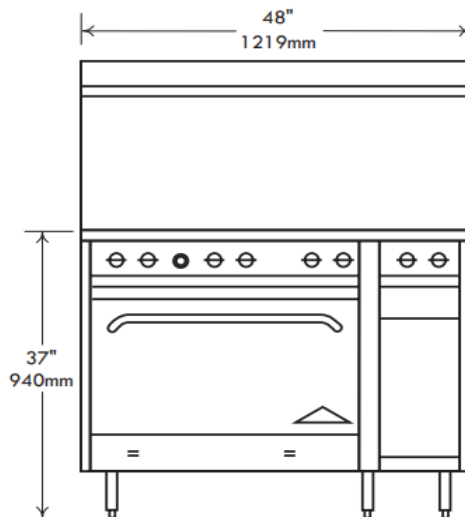

*See website for details

Standard Features, Benefits & Options

OVENS: Large oven measures 31.5" w x 22" d x 14" h for superior baking characteristics and results. Small ovens measure 19.5" w x 22" d x 14" h. Heavy insulation for fuel efficiency. Easy cleaning porcelain and aluminized linings with one nickel plated rack. 3 rack positions with 2 3/4" between rack positions. Large oven features long life, 30,000 BTU cast iron "H" pattern oven burner.

COOKTOPS: Model F3430-36 features (2) open top "star" pattern burners. Front burners are rated at 24,000 BTU's and rear burners are rated at 30,000 BTU's. The large 7" flame spread offers a more efficient burn pattern for small to large pots. Full width crumb trays catch all spillage. Top grates are 12" x 12" cast iron with spillover bowl that also reflects heat for added efficiency. Designed for easy movement of pots across top sections. Stainless steel bullnose-rail is safely flush with the cook tops and functional to straddle pots, skillets and plates and also serves as control protection.

CONSTRUCTION: Easy cleaning, corrosion resistant stainless-steel finish, welded with angle iron and aluminized inner framing. Sturdy 6" heavy duty stainless pipe legs with adjustable feet. Double wall construction with heavy insulation for cooler operation. Installation clearances for non-combustible surfaces are 0" on sides and 0" in the rear, combustible surface clearances are 2" and 2".

CONTROLS: Includes 500° thermostat, 100% safety shut off, automatic standing pilot and brass top burner valves. Pressure regulators are set at the factory for the gas specified. Optimal pressures are 4" WC for natural gas and 10" WC for propane. Manifold size is 3/4" NPT. All controls are tested and confirmed in good working order. Calibration and adjustments are the responsibility of the buyer.

GRIDDLE PLATES: Model F3430-36 features a 36" wide griddle plate rated at 72,000 BTU's. 3/4" thick is standard. SS splash guards tapering to 4". Front grease trough and large capacity grease catch. Optional raised griddle-cheesemelters with rear trough are available up to 36". Maximum rack clearance is 4 1/2".

STORAGE SPACE: Model F3430-36 features (1) extra wide 31" oven with enamel door & bottom linings, as well as (1) small open cabinet used for storing pans. The storage cabinet is 10" wide.

ACCESSORIES & OPTIONS: Convection fan, casters, extra racks, pizza decks, FD oven thermostats, oven spark pilots, chrome griddle plates, 1" thick griddle plates, griddle thermostats, safety pilot griddles, lift off griddles, grill scrapers, cleaning supplies, hose and quick disconnects, control protection bars, storage base in lieu of oven and low backs are some of the standard options and accessories available.

Model #	Top	Base	Total BTU	Approx. Wgt. Kg. / Lbs.
F3430-36	(2) Open Burners & (1) 36" Griddle	- w/ (1) 31.5" Oven & 10" storage space	156,000	336 / 740



WARNING: This product can expose you to certain chemicals, which are known to the State of California to cause cancer or birth defects or other reproductive harm. For more information go to: www.P65Warnings.com

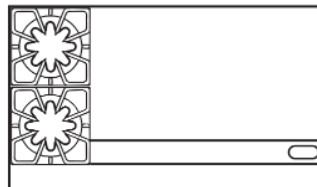

*Actual cook top configuration shown



NOTICE: In an ongoing effort of product development & improvement, Comstock-Castle reserves the right to change specifications and product design without notice. Such modifications do not entitle the buyer to corresponding changes or replacements for previously purchased equipment.



Comstock-Castle Stove Co.
Tel.: 217-223-5070

119 W. Washington St.
Fax: 217-223-0007

Quincy, IL. 62301
www.castlestove.com

