



JOB _____ ITEM # _____

Model # F3430-24-2RB

48" WIDE RANGES



Model F3430-24-2RB

* Picture shown w/ optional casters

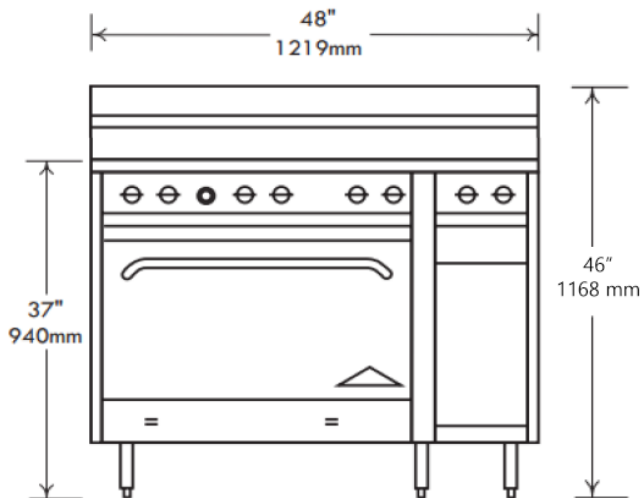

Standard Features, Benefits & Options

CONSTRUCTION: Easy cleaning, corrosion resistant stainless steel finish, welded with angel iron and aluminized inner framing. Sturdy 6" heavy duty stainless pipe legs with adjustable feet. Double wall construction with heavy insulation for cooler operation. Installation clearances for non-combustible surfaces are 0" on sides and 0" in the rear, combustible surface clearances are 2" and 2".

OVENS: Large oven measures 31.5" w x 22" d x 14" h for superior baking characteristics and results. Heavy insulation for fuel efficiency. Easy cleaning porcelain and aluminized linings with one nickel plated rack. 3 rack positions with 2 3/4" between rack positions. Large oven features long life, 30,000 BTU cast iron "H" pattern oven burner. Special "V" shaped baffle directs heat for excellent air circulation.

CONTROLS: Includes 500° thermostat, 100% safety shut off, automatic standing pilot and brass top burner valves. Pressure regulators are set at the factory for the gas specified. Optimal pressures are 4" WC for natural gas and 10" WC for propane. Manifold size is 3/4" NPT. All controls are tested and confirmed in good working order. Calibration and adjustments are the responsibility of the buyer.

GRIDDLE PLATE: 12" increments have 24,000 BTU cast iron burners replacing front to back open burner pairs. 3/4" thick griddle plate is standard. SS splash guards tapering to 4". Front grease trough and large capacity grease catch.

CHAR-BROILER: 12" increments have 30,000 BTU cast iron burners replacing front to back open burner pairs. Flare up reducing cast-iron top grades and radiance for superior heat retention. Front grease trough and large capacity grease catch. SS splash guards tapering to 4". Char-broilers are approved for use in non-combustible locations only. Char-broilers on ranges come standard with a low back.

STORAGE SPACE: Model F3430-24-2RB features (1) small open cabinet used for storing pans. The storage cabinet is 10" wide.

ACCESSORIES & OPTIONS: Convection fan, casters, extra racks, pizza decks, FD oven thermostats, chrome griddles, 1" thick griddle plates, griddle thermostats, safety pilot griddles, hose and quick disconnects, and low backs are some of the standard options available.

| Model # | Width | Depth | Height | Oven Width | Storage Space |
|--------------|-------|-------|--------|------------|---------------|
| F3430-24-2RB | 48" | 30.5" | 46" | 31.5" | 10" W |



*See website for details



WARNING: This product can expose you to certain chemicals, which are known to the State of California to cause cancer or birth defects or other reproductive harm. For more information go to: www.P65Warnings.com

NOTICE: In an ongoing effort of product development & improvement, Comstock-Castle reserves the right to change specifications and product design without notice. Such modifications do not entitle the buyer to corresponding changes or replacements for previously purchased equipment.



Comstock-Castle Stove Co.
Tel.: 217-223-5070

119 W. Washington St.
Fax: 217-223-0007

Quincy, IL. 62301
www.castlestove.com

