

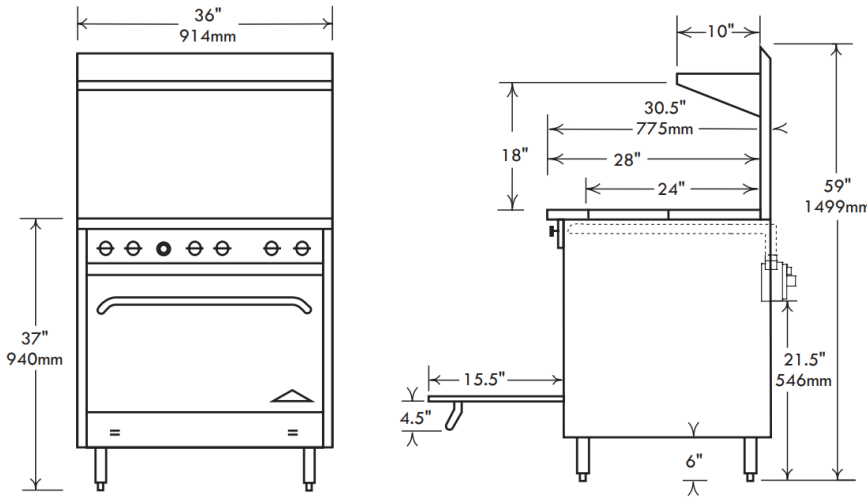

# Model # F330-36

## 36" WIDE RANGE W/ GRIDDLE



Model F330-36

\*Picture shown with optional casters



**WARNING:** This product can expose you to certain chemicals, which are known to the State of California to cause cancer or birth defects or other reproductive harm. For more information go to: [www.P65Warnings.com](http://www.P65Warnings.com)



\*See website for details

## Standard Features, Benefits & Options

**OVEN:** 31.5" w x 22" d x 14" h for superior baking characteristics and results. Heavy insulation for fuel efficiency. Easy cleaning porcelain and aluminized linings with one nickel plated rack. 3 rack positions with 2 3/4" between rack positions. Long life, 30,000 BTU cast iron "H" pattern oven burner combined with special "V" shaped baffle directs heat for excellent air circulation.

**CONSTRUCTION:** Easy cleaning, corrosion resistant stainless steel finish, welded with aluminized inner framing. Sturdy 6" heavy duty stainless pipe legs with adjustable feet. Double wall construction with heavy insulation for operation. Installation clearances for non-combustible surfaces are 0" on sides and 0" in the rear, combustible surface clearances are 2" and 2".

**GRIDDLE PLATE:** Model F330-36 is an all flat top griddle, featuring a 36" wide, 3/4" thick griddle plate with manual controls. Rated at 72,000 total BTU's, the griddle features 4" tapered SS splash guards, front grease trough and large capacity grease catch.

**CONTROLS:** Includes 500° thermostat, 100% safety shut off. Pressure regulators are set at the factory for the gas specified. Optimal pressures are 4" WC for natural gas and 10" WC for propane. Manifold size is 3/4" NPT. All controls are tested and confirmed in good working order. Calibration and adjustments are the responsibility of the buyer.

**ACCESSORIES & OPTIONS:** Convection fan, casters, extra racks, pizza decks, FD oven thermostats, chrome griddle plates, 1" thick griddle plates, griddle thermostats, safety pilot griddles, grill scrapers, cleaning supplies, hose and quick disconnects, control protection bars, storage base in lieu of oven and high back with shelf are some of the standard options and accessories available.

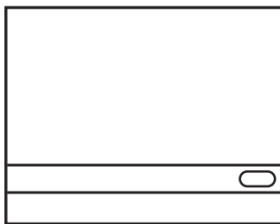

\*Actual cook top configuration shown



Model #	Top	Base	Total BTU	Approx. Wgt. Kg. / Lbs.
F330-36	36" griddle	- w/ (1) 31.5" oven	102,000	580

This chart is intended to be a guide. Adjustments may be made to accommodate the cooking demands of various establishments.

NOTICE: In an ongoing effort of product development & improvement, Comstock-Castle reserves the right to change specifications and product design without notice. Such modifications do not entitle the buyer to corresponding changes or replacements for previously purchased equipment.



Comstock-Castle Stove Co. • 119 W. Washington St. • Quincy, IL. 62301  
 Tel.: 217-223-5070 • Fax: 217-223-0007 • [www.castlestove.com](http://www.castlestove.com)

