

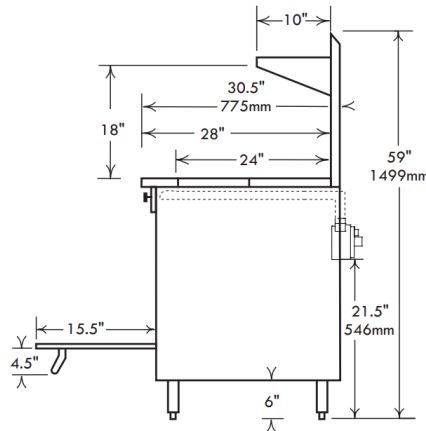

Model # F330-1RB

36" WIDE RANGE W/ CHAR-BROILER

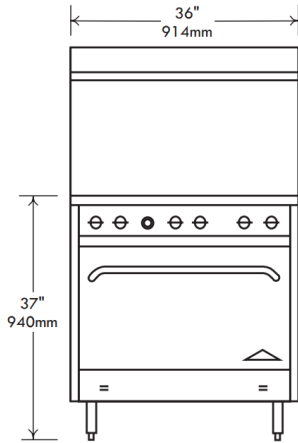

*Drawing not exact



Model F330-1RB

*Picture shown with optional casters



*See website for details

WARNING: This product can expose you to certain chemicals, which are known to the State of California to cause cancer or birth defects or other reproductive harm. For more information go to: www.P65Warnings.com

Standard Features, Benefits & Options

OVEN: 31.5" w x 22" d x 14" h for superior baking characteristics and results. Heavy insulation for fuel efficiency. Easy cleaning porcelain and aluminized linings with one nickel plated rack. 3 rack positions with 2 3/4" between rack positions. Long life, 30,000 BTU cast iron "H" pattern oven burner combined with special "V" shaped baffle directs heat for excellent air circulation.

COOK TOPS: Model F330-1RB features (4) "star" pattern top burners, (front burners are 24,000 BTU's) & 12" wide char-broiler, rated at 30,000 BTU. The large 7" flame spread offers a more efficient burn pattern for small to large pots. Full width crumb trays catch all spillage. Top grates are 12" x 12" cast iron with spillover bowl that also reflects heat for added efficiency. Designed for easy movement of pots across top sections. Stainless steel bullnose-rail is safely flush with the cook tops and functional to straddle pots, skillets and plates and also serves as control protection.

CONSTRUCTION: Easy cleaning, corrosion resistant stainless steel finish, welded with aluminized inner framing. Sturdy 6" heavy duty stainless pipe legs with adjustable feet. Double wall construction with heavy insulation for operation. Installation clearances for non-combustible surfaces are 0" on sides and 0" in the rear, combustible surface clearances are 2" and 2". Ranges with char-broilers come standard with low/stub backsplash & no over shelf for sanitation purposes.

CHAR-BROILER: This model features a 12" wide char-broiler, rated at 30,000 total BTU's. Flare up reducing cast-iron top grates and radiants for superior heat retention. Front grease trough and large capacity grease catch. SS splash guards tapering 4". Char-broilers are approved for use in non-combustible locations only.

CONTROLS: Includes 500° thermostat, 100% safety shut off, automatic standing pilot and brass top burner valves. Pressure regulators are set at the factory for the gas specified. Optimal pressures are 4" WC for natural gas and 10" WC for propane. Manifold size is 3/4" NPT. All controls are tested and confirmed in good working order. Calibration and adjustments are the responsibility of the buyer.

ACCESSORIES & OPTIONS: Convection fan, casters, extra racks, pizza decks, FD oven thermostats, chrome griddle plates, 1" thick griddle plates, griddle thermostats, safety pilot griddles, grill scrapers, cleaning supplies, hose and quick disconnects, control protection bars, storage base in lieu of oven and high back with shelf are some of the standard options and accessories available.

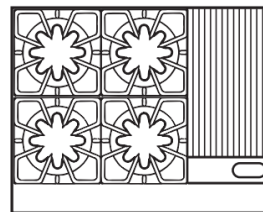

*Actual cook top configuration shown



Model #	Top	Base	Total BTU	Approx. Wgt. Kg. / Lbs.
F330-1RB	(4) open burners 12" char-broiler	- w/ (1) 31.5" Oven	168,000	580

This chart is intended to be a guide. Adjustments may be made to accommodate the cooking demands of various establishments.

NOTICE: In an ongoing effort of product development & improvement, Comstock-Castle reserves the right to change specifications and product design without notice. Such modifications do not entitle the buyer to corresponding changes or replacements for previously purchased equipment.



Comstock-Castle Stove Co. • 119 W. Washington St. • Quincy, IL. 62301
Tel.: 217-223-5070 • Fax: 217-223-0007 • www.castlestove.com

