

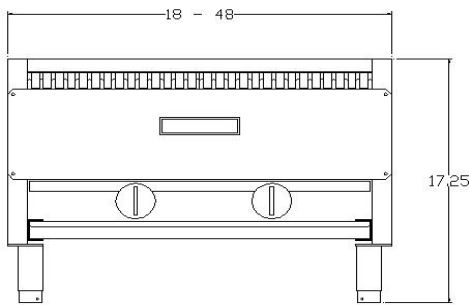

# LAVA BROILER

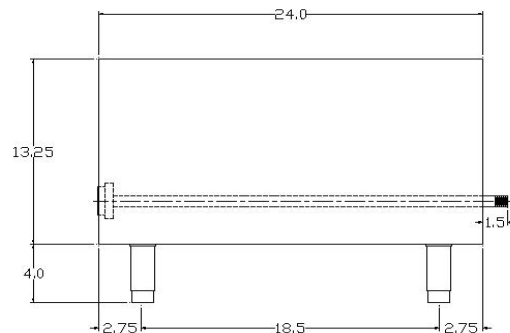

FRONT VIEW



SIDE VIEW

## Standard Features, Benefits & Options

**CONSTRUCTION:** 48" wide x 24" deep x 17¼" tall. Easy cleaning corrosion resistant stainless steel finish. Double wall construction, insulated for energy efficiency.

**CONTROLS:** Model ELB48 char-broiler is equipped with brass gas valves, adjustable standing pilots and pressure regulators.

**BURNERS:** 4, efficient straight burners each rated at 30,000 BTU's. Heavy cast iron bottom grates hold lava rock.

**COOK TOP:** Heavy cast iron top grates each measuring 3" wide x 20¼" deep. Grates feature a cast in trough to channel grease to the front trough to reduce flare-up.

**TESTING:** Optimal pressure is 4" WC for natural gas, 10" WC for propane. ETL design & ETL Sanitation (ANSI-NSF4) certified.



Model #	Width x Depth		Burners ----- Total BTU	Ship Wgt.	
	in.	mm		lbs.	kg.
ELB48	48"	1219	4 ----- 120,000	360	164
	x 24"	X 610			



Comstock-Castle Stove Co. • 119 W. Washington St. • Quincy, IL 62301  
Tel.: 217-223-5070 • Fax.: 217-223-0007 • Web: www.castlestove.com

