

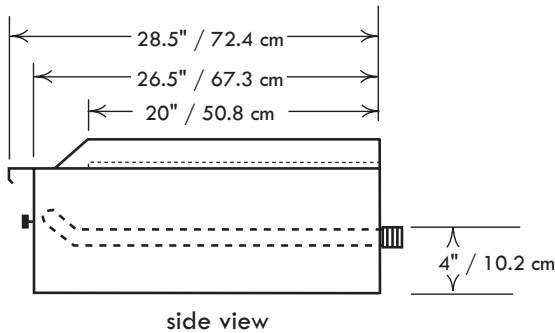

JOB _____ ITEM # _____

Manual Control GRIDDLES

E Series: 20" Cook Depth

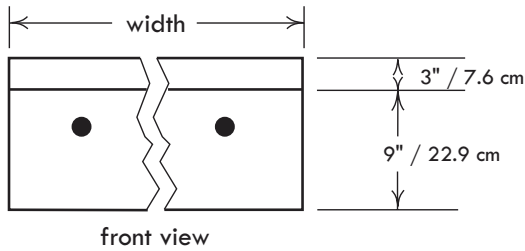

Model EG24



Model EG36



Standard Features, Benefits & Options

CONSTRUCTION: Easy cleaning, stainless steel finish. 3" wide stainless steel bull nose landing across the front is a functional work area for service plates and work utensils as well as control protection. Heavy gauge welded frame construction. Installation clearances for non-combustible surfaces are 0" on the sides and 0" in the rear, combustible surfaces are 4" on the sides and 5" in the rear.

GRIDDLE PLATE: Highly polished to minimize food sticking. 5/8" thick plate is standard, 3/4" and 1" thick is available. 3" high splash guard is standard. Higher and lower sides are also available. 20" deep cooking surface with 4" front, cold zone grease trough. Grease drain slot is 3.5" x 1" and feeds into a seamless, deep, removable grease drawer.

CONTROLS: Equipped with brass gas valves and automatic standing pilots. Pressure regulators are set at the factory for the gas specified. Optimal pressures are 4" WC for natural gas and 10" WC for propane. Manifold size is 3/4" NPT. All controls are tested and confirmed in good working order. Calibration and adjustments are the responsibility of the owner.

BURNERS: 12" incremental griddles feature 25,000 BTU burners, one for each 12" increment. 18", 30" and 42" models feature 2, 4 and 6 burners respectively, each rated at 16,000 BTU.

MATCH-UP: E Series griddles are designed to match up with E char-broilers.

ACCESSORIES & OPTIONS: Sturdy 2 1/2" or 4" heavy duty legs with adjustable feet, thermostats, 3/4" and 1" thick plates, chrome & grooved griddle plates, safety pilot controls, gas hoses, grill scrapers, spatulas, cleaning supplies, carrying handles, knob protectors and matching equipment stands.

SPECIFICATIONS

Model Number	Width in./mm.	Sq.in. surface	Total BTU	Approx. kg/lbs
EG12	12/305	240	25K	48 / 105
EG18	18/457	360	32K	57 / 125
EG24	24/610	480	50K	68 / 150
EG30	30/762	600	64K	80 / 175
EG36	36/914	720	75K	91 / 200
EG42	42/1069	840	96K	107 / 235
EG48	48/1219	960	100K	125 / 275
EG60	60/1524	1200	125K	152 / 335
EG72	72/1829	1440	150K	205 / 450

Thermostat control models available.

NOTICE: In an ongoing effort of product development & improvement, Comstock-Castle reserves the right to change specifications and product design without notice. Such modifications do not entitle the buyer to corresponding changes or replacements for previously purchased equipment.



Comstock-CastleStoveCo. • 119W. Washington St. • Quincy, IL. 62301
Tel.: 217-223-5070 • Fax: 217-223-0007 • www.castlestove.com

