

Model # F3430-12-2RB

48" WIDE RANGES



Model F3430-12-2RB

*image not exact

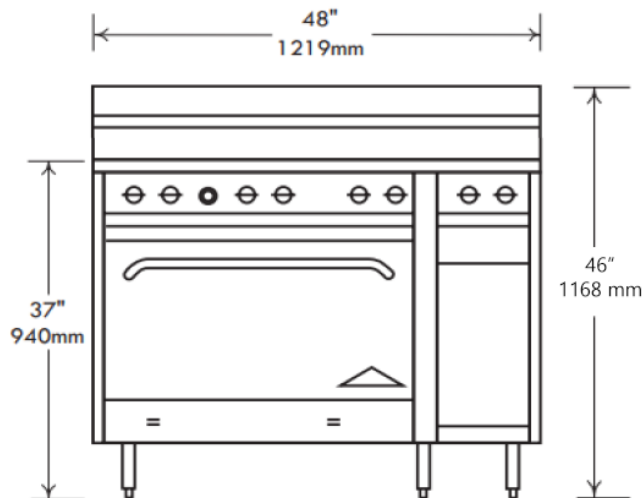

*See website for details

Standard Features, Benefits & Options

OVENS: Large oven measures 31.5" w x 22" d x 14" h for superior baking characteristics and results. Small ovens measure 19.5" w x 22" d x 14" h. Heavy insulation for fuel efficiency. Easy cleaning porcelain and aluminized linings with one nickel plated rack. 3 rack positions with 2 3/4" between rack positions. Large oven features long life, 30,000 BTU cast iron "H" pattern oven burner.

COOKTOPS: Model F3430-12-2RB features (2) open top "star" pattern burners. Front burners are rated at 24,000 BTU's and rear burners are rated at 30,000 BTU's. The large 7" flame spread offers a more efficient burn pattern for small to large pots. Full width crumb trays catch all spillage. Top grates are 12" x 12" cast iron with spillover bowl that also reflects heat for added efficiency. Designed for easy movement of pots across top sections. Stainless steel bullnose-rail is safely flush with the cook tops and functional to straddle pots, skillets and plates and also serves as control protection.

CONTROLS: Includes 500° thermostat, 100% safety shut off, automatic standing pilot and brass top burner valves. Pressure regulators are set at the factory for the gas specified. Optimal pressures are 4" WC for natural gas and 10" WC for propane. Manifold size is 3/4" NPT. All controls are tested and confirmed in good working order. Calibration and adjustments are the responsibility of the buyer.

GRIDDLE PLATE: Model F3430-12-2RB features a 12" wide griddle plate rated at 24,000 BTU's with cast iron burners. 3/4" thick griddle plate is standard. SS splash guards tapering 4". Front grease trough and large capacity grease catch.

CHAR-BROILER: Model F3430-12-2RB features a 24" wide char-broiler rated at 60,000 BTU's. Cast iron burners with flare up reducing cast iron top grates & radiants for superior heat retention. SS splash guards tapering 4". Char-broilers on ranges come standard with a low back and are approved for use in non-combustible locations only.

STORAGE SPACE: Model F3430-12-2RB features (1) small open cabinet used for storing pans. The storage cabinet is 10" wide.

ACCESSORIES & OPTIONS: Convection fan, casters, extra racks, pizza decks, FD oven thermostats, oven spark pilots, chrome griddle plates, 1" thick griddle plates, griddle thermostats, safety pilot griddles, lift off griddles, grill scrapers, cleaning supplies, hose and quick disconnects, control protection bars, storage base in lieu of oven and low backs are some of the standard options and accessories available.

| Model # | Width | Depth | Height | Oven Width | Storage Space |
|--------------|-------|-------|--------|------------|---------------|
| F3430-12-2RB | 48" | 30.5" | 46" | 31.5" | 10" W |



WARNING: This product can expose you to certain chemicals, which are known to the State of California to cause cancer or birth defects or other reproductive harm. For more information go to: www.P65Warnings.com

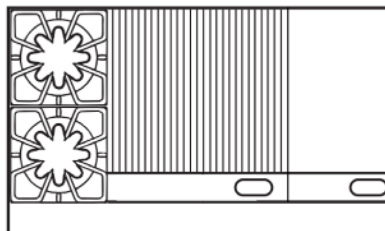

*Actual cook top configuration shown



NOTICE: In an ongoing effort of product development & improvement, Comstock-Castle reserves the right to change specifications and product design without notice. Such modifications do not entitle the buyer to corresponding changes or replacements for previously purchased equipment.

