



HAND BLENDER XM-32

Professional immersion blender. 0.54 Hp / 400 W.



DYNAMIC PREPARATION
COMMERCIAL HAND BLENDERS

SALES DESCRIPTION

- ✓ Fixed speed motor block.
- ✓ 14.41" detachable arm.
- ✓ Designed for continuous use in recipients of up to 48 qt.

All-in-one

- ✓ Professional hand blender designed for carrying out different preparations without the need for add-on tools.
- ✓ Professional Y-blade, made from tempered steel and with a long-duration cutting edge.
- ✓ Fixed speed.
- ✓ Designed to work in recipients of up to 45 l.

Exclusive TiltStop system

- ✓ Your hand blender will stop in case of a fall or excessive tilt from the vertical position.
- ✓ Moreover, it won't initiate unless it's in the correct usage position.
- ✓ This ensures optimal operation and increases the operator's safety at the workplace.

Maximum comfort for the user

- ✓ Compact design: logical and manageable size.
- ✓ Ergo-design & bi-mat-grip: external casing made in two materials for an ergonomic hold. Anti-slip grip. Optimum inclination of handle, minimising fatigue.
- ✓ Click-on-arm: detachable arm with fast and secure closure.
- ✓ Hood designed to avoid splashes.
- ✓ Intuitive use: very simple operation. LED warning light in two colours to indicate the status of the machine.
- ✓ Possibility of continuous operation.

Built to last

- ✓ Professional performance: capable of carrying out prolonged work without the casing overheating.
- ✓ Life-plus: equipped with a motor which has passed all of the most demanding usage tests.

- ✓ Studied geometry: casing designed to avoid rolling and falling.
- ✓ Ultra-durable arms designed to stand high temperatures in operation.
- ✓ Easy to clean: the arm can be washed under the tap or in the dishwasher.
- ✓ Approved by NSF: guaranteed safety and hygiene.

INCLUDES

- ✓ Fixed speed motor block.
- ✓ MA-32 mixer arm.
- ✓ Wall mount.

OPTIONAL

- MA-31 mixer arm.
- MA-33 mixer arm.
- "Quick fix" clamp.
- Clamp sliding frame.

ACCESSORIES

- Motor unit MM-30
- Mixer arms MA-30
- Quick-Fix bowl clamp

SPECIFICATIONS

Total loading: 0.54 Hp / 400 W
 Maximum recipient capacity: 48 qt
 Motor speed: 12000 rpm
 Blade diameter: 2.17"
 Blade guard diameter: 3.6"

Length

Liquidising arm length: 14.41"
 Total length: 26.54"
 Net weight: 7.85 lb
 Noise level (1m.): <80 dB(A)
 Crated dimensions
 17.9 x 18.7 x 4.6 "
 Gross weight: 10.0 lbs.

AVAILABLE MODELS

3030797 Immersion blender XM-32 120/50-60/1

* Ask for special versions availability





HAND BLENDER XM-32

Professional immersion blender. 0.54 Hp / 400 W.



DYNAMIC PREPARATION
COMMERCIAL HAND BLENDERS

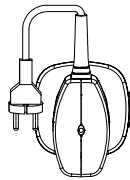
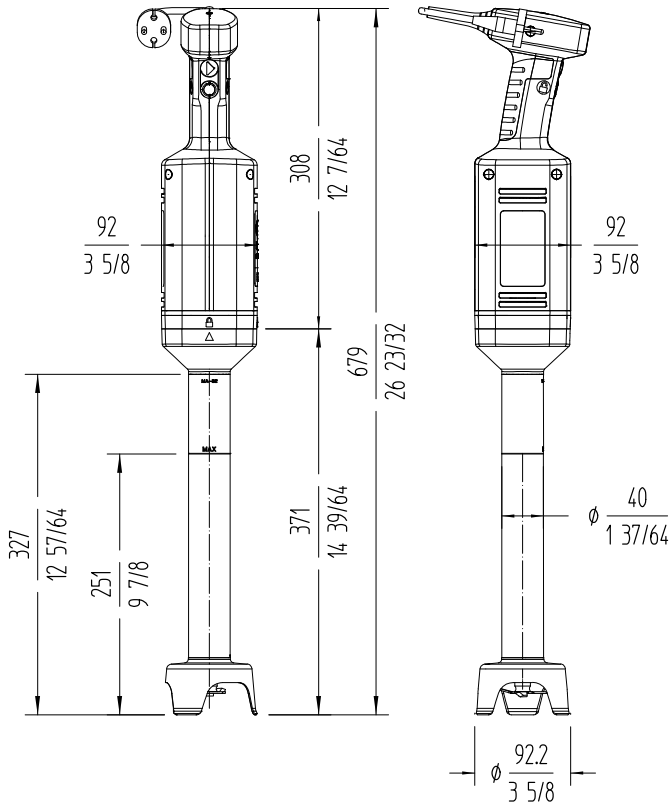

sammic | sammic.us
 Food Service Equipment Manufacturer

usa@sammic.com phone +1 (224) 307-2232
 1225 Hartrey Avenue toll free +1 844 275 3848
 60202-1056 Evanston, IL



Project	Date
Item	Qty
Approved	

product sheet
updated 22/01/2026