



BLENDER B-20

Professional beater. 0.41 Hp / 300 W.



DYNAMIC PREPARATION
COMMERCIAL HAND BLENDERS

SALES DESCRIPTION

- ✓ Variable speed motor block.
- ✓ Whisk with capacity for 2 to 30 egg whites.

Professional performance

- ✓ Vario-speed: variable speed.
- ✓ Smooth Control: smart speed control. The new SmoothControl system provides a faster response and better stability to the machine. It also improves the start-up under load and limits over-acceleration when removing the machine and in no-load situations.
- ✓ Beater with capacity for 2 to 30 egg whites.

Maximum comfort for the user

- ✓ Compact design: logical and manageable size.
- ✓ Ergo-design & bi-mat-grip: external casing made in two materials for an ergonomic hold. Anti-slip grip. Optimum inclination of handle, minimising fatigue.
- ✓ Click-on-arm: detachable arm with fast and secure closure.
- ✓ Intuitive use: very simple operation. Warning light when the machine is connected to the mains.

Built to last

- ✓ Professional performance: capable of carrying out prolonged work without the casing overheating.
- ✓ Life-plus: equipped with a motor which has passed all of the most demanding usage tests.
- ✓ Studied geometry: casing designed to avoid rolling and falling.
- ✓ Easy to clean: detachable, dishwasher safe whisks.

- ✓ Approved by NSF: guaranteed safety and hygiene.

INCLUDES

- ✓ Variable speed motor block.
- ✓ Whisk BA-20.
- ✓ Wall mount.

OPTIONAL

- MA-21 mixer arm.
- MA-22 mixer arm.

ACCESSORIES

- Motor unit MM-20V
- Whisk BA-20
- Mixer arms MA-20

SPECIFICATIONS

Total loading: 0.41 Hp / 300 W
 Motor speed: 200 - 1800 rpm
 Capacity (egg whites): 2 - 30
 Length
 Revolving arm length: 12.05"
 Total length (with revolving arm): 22.44"
 Net weight: 5.77 lb
 Noise level (1m.): <80 dB(A)
 Crated dimensions
 17.3 x 14.8 x 4.1 "
 Gross weight: 7.3 lbs.

AVAILABLE MODELS

3030770 Beater B-20 120/50-60/1

* Ask for special versions availability



SAMMIC, S.L. · Basarte, 1
 20720 AZKOITIA (Gipuzkoa) · SPAIN

Intertek

product sheet
 updated 05/02/2026



BLENDER B-20

Professional beater. 0.41 Hp / 300 W.



DYNAMIC PREPARATION
COMMERCIAL HAND BLENDERS

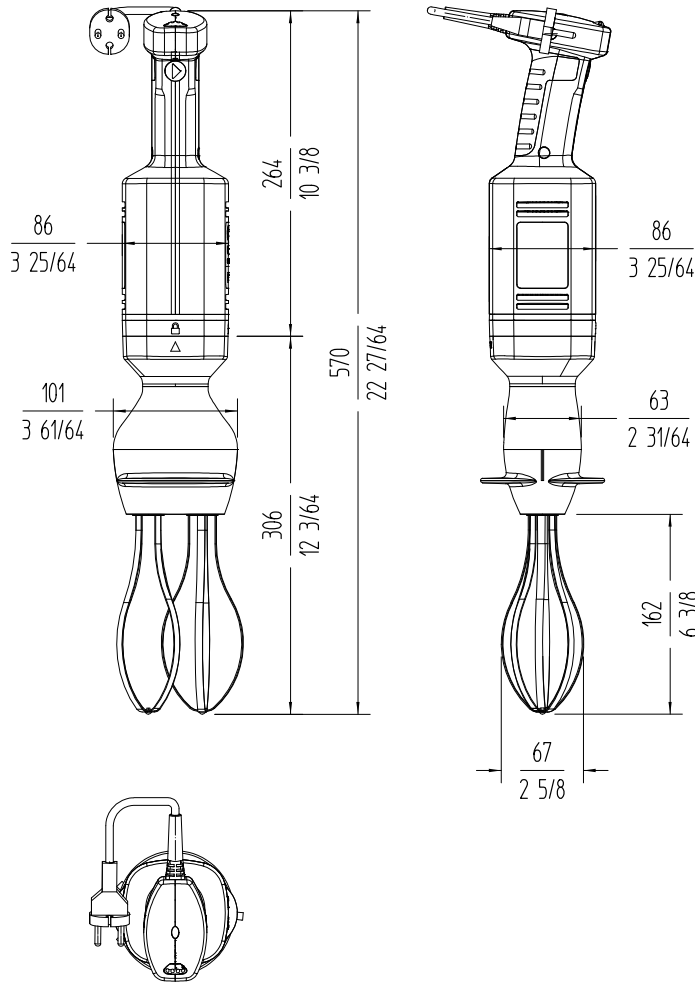

sammic | sammic.us
Food Service Equipment Manufacturer

usa@sammic.com phone +1 (224) 307-2232
 1225 Hartrey Avenue toll free +1 844 275 3848
 60202-1056 Evanston, IL



Project	Date
Item	Qty
Approved	

product sheet
updated 05/02/2026