



HAND BLENDER XM-22

Professional immersion blender. 0.41 Hp / 300 W.



DYNAMIC PREPARATION
COMMERCIAL HAND BLENDERS

SALES DESCRIPTION

- ✓ Variable speed motor block.
- ✓ 11.8" detachable arm.
- ✓ Designed for continuous use in recipients of up to 16 qt.

All-in-one

- ✓ Professional hand blender designed for carrying out different preparations without the need for add-on tools.
- ✓ Professional Y-blade, made from tempered steel and with a long-duration cutting edge.
- ✓ Vario-speed: variable speed.
- ✓ Smooth Control: smart speed control. The new SmoothControl system provides a faster response and better stability to the machine. It also improves the start-up under load and limits over-acceleration when removing the machine and in no-load situations.
- ✓ Designed to work in recipients of up to 15 l.

Maximum comfort for the user

- ✓ Compact design: logical and manageable size.
- ✓ Ergo-design & bi-mat-grip: external casing made in two materials for an ergonomic hold. Anti-slip grip. Optimum inclination of handle, minimising fatigue.
- ✓ Click-on-arm: detachable arm with fast and secure closure.
- ✓ Hood designed to avoid splashes.
- ✓ Intuitive use: very simple operation. Warning light when the machine is connected to the mains.

Built to last

- ✓ Professional performance: capable of carrying out prolonged work without the casing overheating.
- ✓ Life-plus: equipped with a motor which has passed all of the most demanding usage tests.
- ✓ Studied geometry: casing designed to avoid rolling and falling.

- ✓ Ultra-durable arms designed to stand high temperatures in operation.
- ✓ Easy to clean: detachable, dishwasher safe arm.
- ✓ Approved by NSF: guaranteed safety and hygiene.

INCLUDES

- ✓ Variable speed motor block.
- ✓ MA-22 mixer arm.
- ✓ Wall mount.

OPTIONAL

- MA-21 mixer arm.
- Whisk BA-20.

ACCESSORIES

- Motor unit MM-20V
- Whisk BA-20
- Mixer arms MA-20

SPECIFICATIONS

Total loading: 0.41 Hp / 300 W
 Maximum recipient capacity: 16 qt
 Motor speed: 1500 - 15000 rpm
 Blade diameter: 2"
 Blade guard diameter: 3.23"

Length

Liquidising arm length: 11.8"
 Total length: 22.2"
 Net weight: 5.26 lb
 Noise level (1m.): <80 dB(A)
 Crated dimensions
 17.3 x 14.8 x 4.1 "
 Gross weight: 7.2 lbs.

AVAILABLE MODELS

3030758 Immersion blender XM-22 120/50-60/1

* Ask for special versions availability





HAND BLENDER XM-22

Professional immersion blender. 0.41 Hp / 300 W.



DYNAMIC PREPARATION
COMMERCIAL HAND BLENDERS

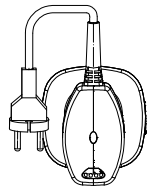
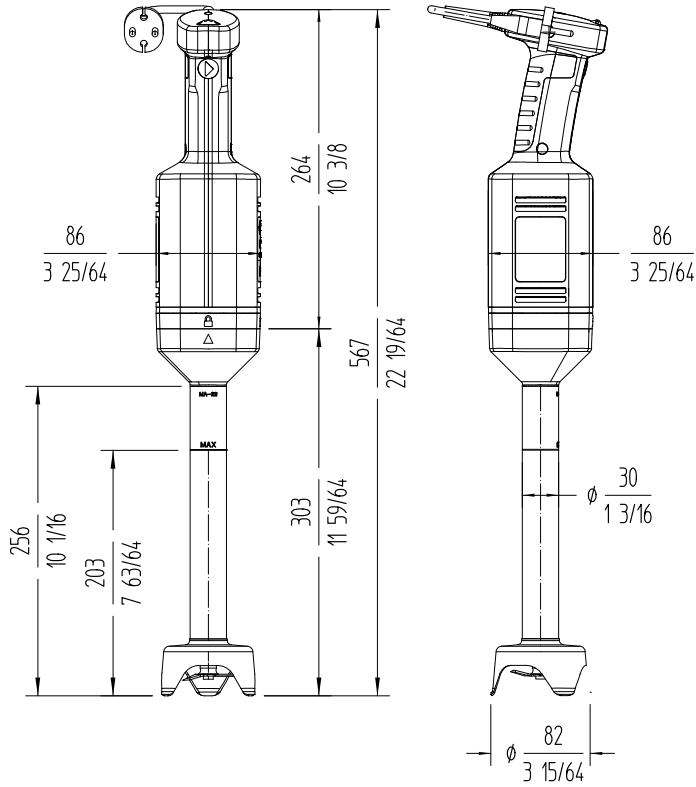

sammic | sammic.us
Food Service Equipment Manufacturer

usa@sammic.com phone +1 (224) 307-2232
1225 Hartrey Avenue toll free +1 844 275 3848
60202-1056 Evanston, IL



Project	Date
Item	Qty
Approved	

product sheet
updated 22/01/2026