



HAND BLENDER XM-12

Compact immersion blender. 0.33 Hp / 240 W.



DYNAMIC PREPARATION
COMMERCIAL HAND BLENDERS

SALES DESCRIPTION

- ✓ The most delicate preparations, airy blendings, smooth purees with no need of add-on tools.
- ✓ Designed for continuous use.
- ✓ Ideal for mise en place.
- ✓ Maximum comfort of use in recipients of up to 10.6 qt.

All-in-one

- ✓ Versatility without add-on tools.
- ✓ Tri-blade, professional, made of tempered steel and equipped with a long lasting cutting edge.
- ✓ Vario-speed: adjustable speed.
- ✓ Smooth Control: smart speed control. The new SmoothControl system provides faster response and better stability to the machine. It also improves the start-up under load and limits over-acceleration when removing the machine and in no-load situations.
- ✓ Ideal for mise-en-place and support in service.
- ✓ Designed to work with maximum comfort in recipients of up to 10 l of capacity.
- ✓ In option: shorter MA-11 mixarm.

Maximum comfort for the user

- ✓ Compact design: logical and manageable size.
- ✓ Ergo-design & bi-mat-grip: the external casing, in two materials, allows an ergonomic hold with an anti-slip grip and the handle features optimum inclination to minimise fatigue.
- ✓ Click-on-arm: detachable arm with quick and safe locking.
- ✓ Hood designed to avoid splashes during work.
- ✓ Intuitive use: very simple operation. Includes warning light when the machine is connected to the mains.

Designed to last

- ✓ Professional performance: it is capable of carrying out prolonged work without overheating.

- ✓ Life-plus: equipped with a motor which has passed all of the most demanding usage tests.
- ✓ Studied geometry: casing designed to avoid rolling and falling.
- ✓ Ultra-durable arms designed to stand high temperatures in operation.
- ✓ Easy to clean: the arm can be washed under the tap or in the dishwasher.
- ✓ Approved by NSF: guaranteed safety and hygiene.

INCLUDES

- ✓ Variable speed motor block.
- ✓ MA-12 mixer arm.

OPTIONAL

- MA-11 mixer arm.
- Emulsionizer PRO 1.0.

ACCESSORIES

- Motor unit MM-10V
- Emulsionizer PRO 1.0
- Mixer arms MA-10

SPECIFICATIONS

Total loading: 0.33 Hp / 240 W
 Maximum recipient capacity: 10.6 qt
 Motor speed: 1500 - 15000 rpm
 Blade diameter: 1.75"
 Blade guard diameter: 2.56"

Length

Liquidising arm length: 8.8"
 Total length: 17.6"
 Net weight: 3.33 lb
 Noise level (1m.): <80 dB(A)
 Crated dimensions
 19.5 x 3.1 x 7.1 "
 Gross weight: 4.3 lbs.

AVAILABLE MODELS

3030740 Immersion blender XM-12 120/50-60/1

* Ask for special versions availability





HAND BLENDER XM-12

Compact immersion blender. 0.33 Hp / 240 W.



DYNAMIC PREPARATION
COMMERCIAL HAND BLENDERS

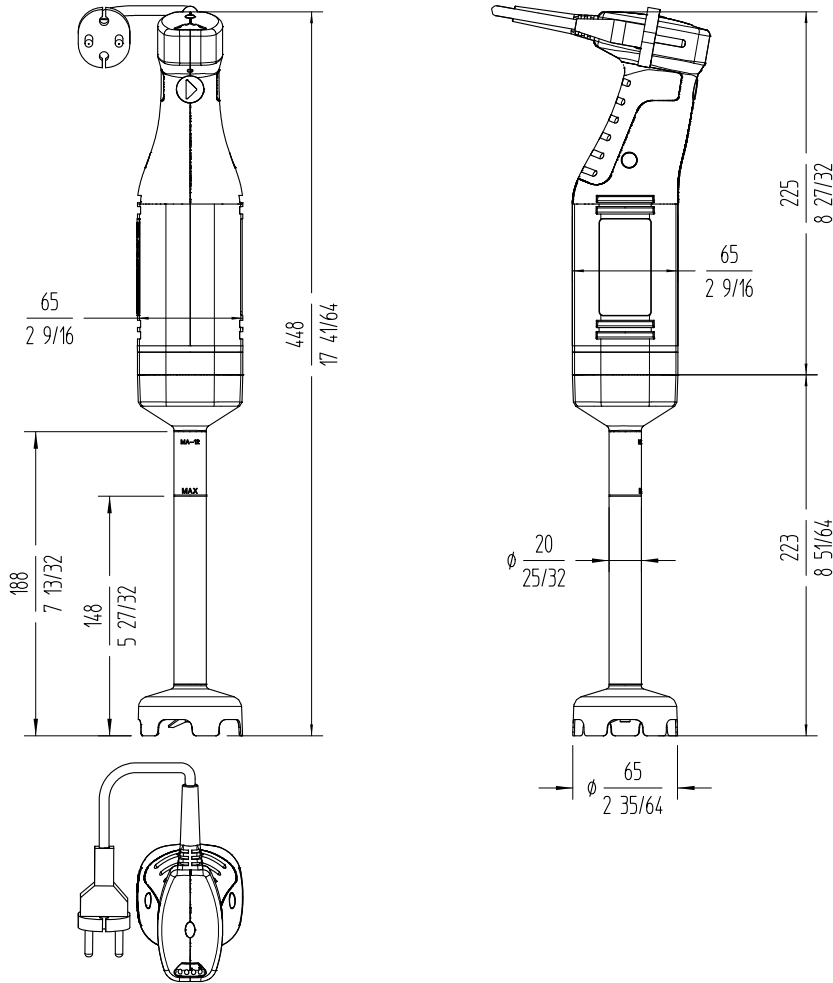

sammic | sammic.us
Food Service Equipment Manufacturer

usa@sammic.com phone +1 (224) 307-2232
 1225 Hartrey Avenue toll free +1 844 275 3848
 60202-1056 Evanston, IL



Project	Date
Item	Qty
Approved	

product sheet
updated 22/01/2026