

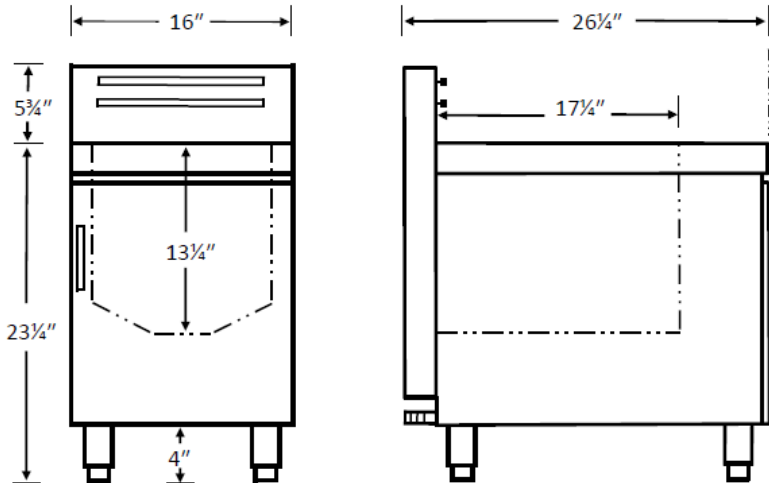

CORN DOG FRYER



Standard Features, Benefits & Options

model CDFL-C-1

CONSTRUCTION: Easy cleaning, corrosion resistant stainless steel finish, rugged welded inner framing. Double wall construction with heavy insulation combined with a special flue design for efficient operation. Adjustable 4" stainless steel legs for easy leveling. Hinged front door protects controls. Fry basket hanger bars are built onto the tank below the flue top for safe basket hanging to prevent oil from dripping into the flue when using optional baskets.

CONTROLS: Reliable non-electric snap action thermostat maintains consistent frying temperatures. The sensing elements are located low in the tank for more accurate temperature controlling especially as heat rises in the oil to assure proper frying temperatures for the entire length of the corn dogs. A safety pilot valve is standard to shut down gas flow in the unlikely event the pilot goes out. A double safety, "hi-limit" control will shut down the fryer in the improbable event the thermostat malfunctions. Gas pressure regulator is included. Optimal gas pressures are 10" WC for LP/propane gas or 4" for natural gas. The manifold size is 3/4" NPT. All controls are tested and confirmed in good working order. Calibration and adjustments are the responsibility of the user.

BURNERS: Powerful jet burners rated at 80,000 BTU's total for very fast frying and recovery to deliver a perfectly fried, golden corn dog.

TANK: Easy cleaning all stainless steel is 13 1/4" deep to accommodate foot long corn dogs. A 3/4" drain valve for rapid draining is located behind the door panel. Tank holds 60 lbs. of shortening.

ACCESSORIES: 2 each, 6 - clip skewers are included with each fryer. Additional 6 - clip skewers are available. Optional accessories include a tank insert to allow fry baskets to be used. Fry baskets are also available.

SPECIFICATIONS		
Model	CDFL-C-1	CDFL-F-1
Width	16"	16"
Depth	26 1/4"	26 1/4"
Height to flue top	29"	42"
Height to tank top	23 3/4"	36"
Ship weight	120 lbs.	155 lbs.
Ship dimensions	29" x 19" x 38"	29" x 19" x 45"
Uncrated weight	90 lbs.	115 lbs.
Total BTU	80,000 BTU's	80,000 BTU's
Tank depth	13 1/4"	13 1/4"
Tank width	13"	13"
Tank front to back	18"	18"
Fat capacity, gallons	7 1/2 - 9 gallons	7 1/2 - 9 gallons
Fat capacity, pounds	60 - 70 lbs.	60 - 70 lbs.

Comstock-Castle Stove Co.
 Quincy, IL. USA • 217-223-5070
www.castlestove.com