

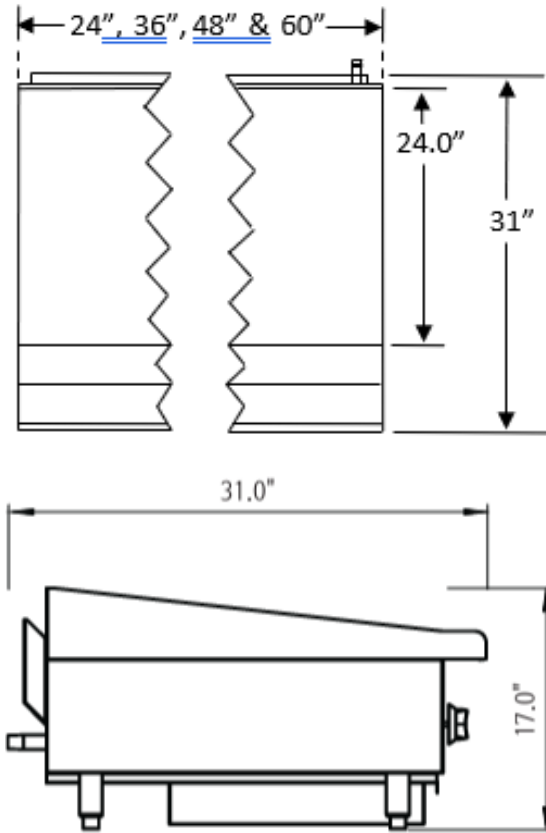

# CHROME GRIDDLES

24" Deep Cook Surface, Thermo Control  
24", 36", 48" & 60" widths  
CCTG31-C Series



Model CCTG3148-C-1



See website for detail

## Standard Features, Benefits & Options

**CONSTRUCTION:** 24", 36", 48" & 60" wide models available. Easy cleaning, corrosion resistant stainless steel finish. Double wall construction. Bull-nose landing. 4" tall adjustable legs. High capacity stainless steel grease drawer.

**CONTROLS:** Thermostat control, 1 every 12" for precision temperature control. Front accessible automatic standing pilots and pressure regulators.

**BURNERS:** Durable & efficient cast iron "H" shaped burners are rated at 30,000 BTU's each provide even heating across the cooking surface. 1 burner per 12" increment.

**GRIDDLE PLATE:** High polish carbon alloy steel with reflective chrome plated cook surface, 1" thick by 24" deep griddle plate.

**TESTING:** Optimal pressure is 5" WC for natural gas, 10" WC for propane. ETL design & ETL Sanitation (ANSI-NSF4) certified.

Model #	Width x Depth		Burners Total BTU	Ship Wgt.	
	in.	mm		lbs.	kg.
CCTG3124-C-1	24" x 31"	610 x 787	2 ----- 60,000	290	132
CCTG3136-C-1	36" x 31"	914 x 787	3 ----- 90,000	400	182
CCTG3148-C-1	48" x 31"	1219 x 787	4 ----- 120,000	520	260
CCTG3160-C-1	60" x 31"	1524 x 787	5 ----- 150,000	690	314



Comstock-Castle Stove Co. • 119 W. Washington St. • Quincy, IL. 62301  
Tel.: 217-223-5070 • Fax.: 217-223-0007 • Web: [www.castlestove.com](http://www.castlestove.com)

