

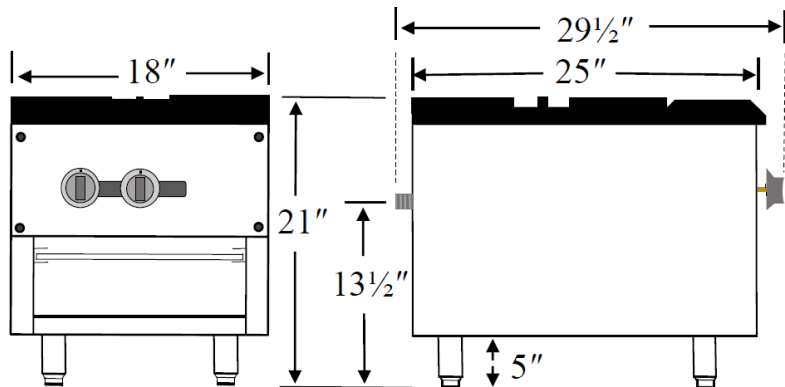

Est.1838 • Commercial Cooking Equipment

STOCK POT STOVES

CCSP Series



Model CCSP-1

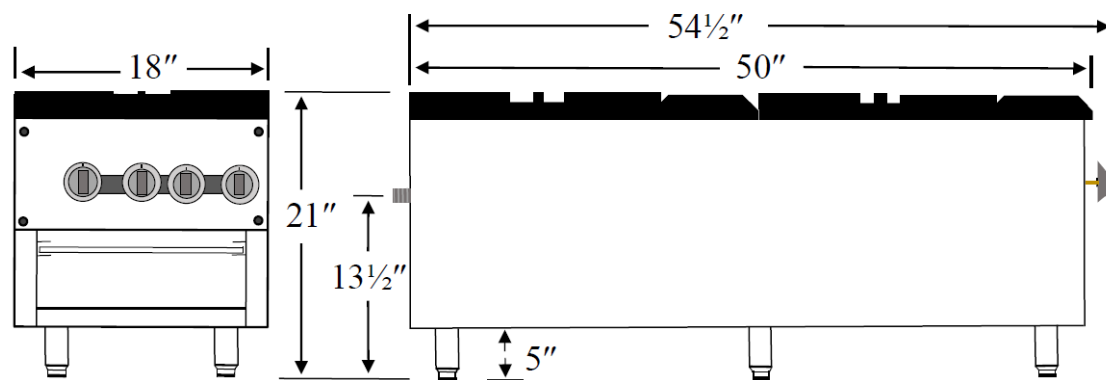

Standard Features, Benefits & Options

CONSTRUCTION: Heavy gauge frame for rugged usage. Easy cleaning stainless steel finish. 5" heavy duty stainless legs with adjustable feet up to an additional 2". Cast iron top grate with 6 3/4" cast-in bullnose landing accommodating 14" to 24" diameter pots.

CONTROLS: CCSP models are equipped with high BTU gas valves, automatic standing pilots, pressure regulators and cool to the touch control knobs. Double venturi, cast iron burners rated up to a total of 110,000 BTU's per 18" x 25" section.

TESTING: 3/4" gas lines are factory tested before shipment. Optimal pressure is 4" WC for natural gas, 10" for propane gas.

ACCESSORIES & OPTIONS: Gas hoses, wok rings and set screw knobs.

SPECIFICATIONS:				
Model	Width x Depth	Total Gas BTU		Ship Weight
		Natural	LP	
CCSP-1	18" x 25"	110,000	90,000	150 lbs.
CCSP-2	18" x 50"	220,000	180,000	285 lbs.



Comstock-Castle Stove Co. • 119 W. Washington St. • Quincy, IL. 62301
 Tel.: 217-223-5070 • Fax.: 217-223-0007 • Web: www.castlestove.com

