

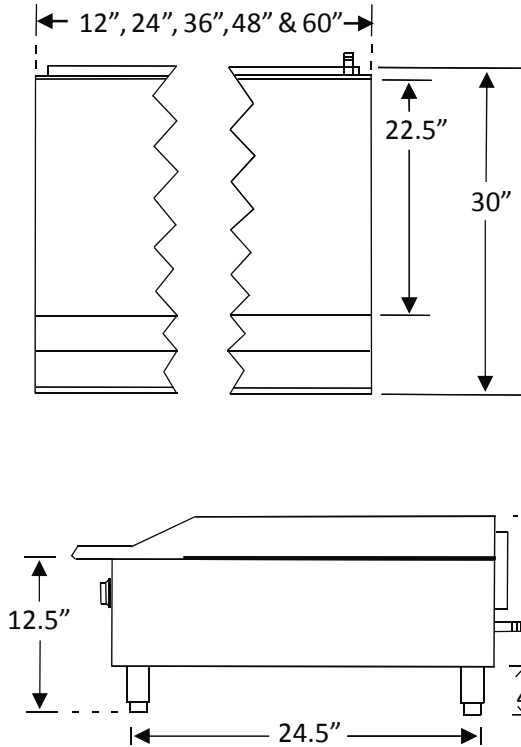

# GRIDDLES

Thermostat Control CCHG-T Series  
12", 24", 36", 48" & 60" widths



Model CCHG24T-1



## Standard Features, Benefits & Options

**CONSTRUCTION:** 24", 36", 48" & 60" wide models available. Easy cleaning, corrosion resistant stainless steel finish. Double wall construction. 3¼" bull-nose landing. 4" tall adjustable legs. High capacity stainless steel grease drawer.

**CONTROLS:** Thermostat control from 200° - 450° every 12" for accurate temperature control. Front accessible automatic standing pilots and pressure regulators. 3/4" manifold connection.

**BURNERS:** Efficient stainless steel "U" shaped burners are rated at 30,000 BTU's each provide even heating across the cooking surface. 1 burner per 12" increment.

**GRIDDLE PLATE:** High polish cold roll steel, 1" thick by 22.5" deep plate, 12" model is ¾" thick. 3" grease trough. Plate seams are welded to prevent gap seepage.

**TESTING:** Optimal pressure is 5" WC for natural gas, 10" WC for propane. ETL design & ETL Sanitation (ANSI-NSF4) certified.

Model #	Packing inches ----- millimeters	Burners ----- Total BTU	Net Wgt. lbs. / kg.	Gross Wgt. lbs. / kg.
CCHG-12T	35 x 18 x 20 89 x 46 x 52	1 ----- 30,000	100 / 45	130 / 59
CCHG-24T-1	35 x 35 x 20 89 x 89 x 52	2 ----- 60,000	220 / 100	275 / 125
CCHG-36T-1	42 x 35 x 20 107 x 89 x 52	3 ----- 90,000	310 / 141	380 / 173
CCHG-48T-1	53 x 35 x 20 134 x 89 x 52	4 ----- 120,000	420 / 191	500 / 227
CCHG-60T-1	65 x 35 x 20 164 x 89 x 52	5 ----- 150,000	520 / 236	610 / 277



Comstock-Castle Stove Co. • 119 W. Washington St. • Quincy, IL. 62301  
Tel.: 217-223-5070 • Fax.: 217-223-0007 • Web: [www.castlestove.com](http://www.castlestove.com)

