

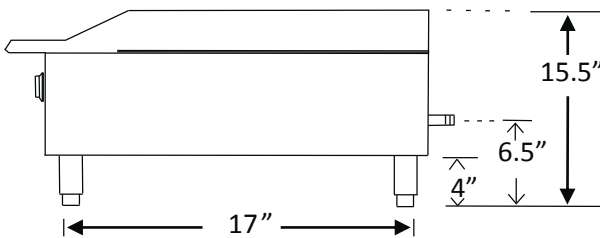

# BROILERS

Lava Style CCELB Series  
16", 24", 36", 48" & 60" widths

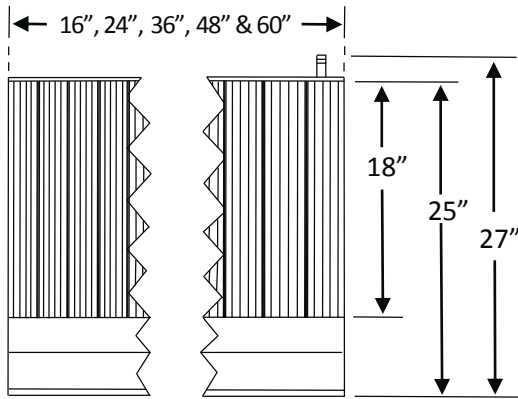

Model CCELB24



## Standard Features, Benefits & Options

**CONSTRUCTION:** 16", 24", 36", 48" & 60" wide models available. Easy cleaning, corrosion resistant G90 galvanized finish. Double wall construction. 4" bull-nose landing. 4" tall adjustable legs. 3" grease trough. Full width drip tray.

**CONTROLS:** Castle char-broilers are equipped with brass gas valves, front accessible automatic standing pilots, pressure regulators and cool to the touch control knobs. 3/4" manifold connection.

**BURNERS:** Efficient stainless steel "U" shaped burners are rated at 30,000 BTU's each provide even heating across the cooking surface.

**BROILER:** Heavy 6" wide cast iron tilt-able top grates. Heavy cast iron bottom grates to hold lava stones.

**TESTING:** Optimal pressure is 4" WC for natural gas, 10" WC for propane. ETL design & sanitation certified.

Model #	Packing inches ----- millimeters	Burners ----- Total BTU	Net Wgt. lbs. / kg.	Gross Wgt. lbs. / kg.
CCELB16	19 x 30 x 20 49 x 78 x 50	1 30,000	85 / 39	105 / 48
CCELB24	28 x 30 x 20 70 x 78 x 50	2 60,000	124 / 56	150 / 68
CCELB36	39 x 30 x 20 98 x 78 x 50	3 90,000	163 / 74	210 / 95
CCELB48	50 x 30 x 20 128 x 78 x 50	4 120,000	235 / 107	290 / 132
CCELB60	63 x 30 x 20 161 x 78 x 50	5 150,000	290 / 132	385 / 175



Comstock-Castle Stove Co. • 119 W. Washington St. • Quincy, IL. 62301  
Tel.: 217-223-5070 • Fax.: 217-223-0007 • Web: [www.castlestove.com](http://www.castlestove.com)

