

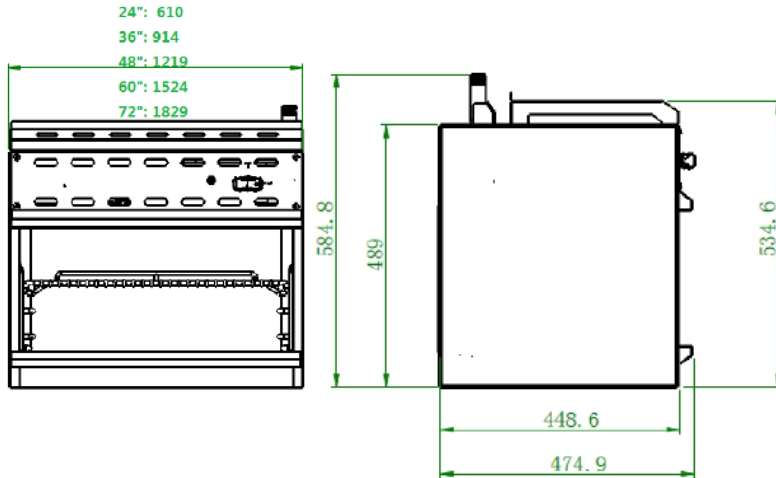

# CHEESE-MELTERS

CCCM Series



Model CCCM-36



## Standard Features & Benefits

**CONSTRUCTION:** Heavy gauge welded framing, stainless steel front, top, sides & crumb / drip tray, insulated side panels. Welded & polished corners.

**BURNER & CONTROLS:** Instant on-off / high-low infra-red burners for fast heating, rated at 10,000 BTU's for each 12" width increment. ETL certified brass gas valves. 3/4" gas connection.

**MELTING CAVITY:** Easy sliding heavy duty 12" deep nickel plated wire rack with 3 rack positions. Safety stop mechanisms prevent rack from falling out & food from falling off the back of rack. All rack widths are 3" narrower than the appliance. Minimum & maximum rack clearances are 4" & 8 1/4".

**TESTING:** Optimal pressure is 5" WC for natural gas, 10" WC for propane. ETL design & ETL Sanitation (ANSI-NSF4) certified.

### Specification Chart

Model #	Packing Size Centimeters ----- Inches w. x d. x h.	BTU Rating	Net Wgt. Lbs. / Kg.	Gross Wgt. Lbs. / Kg.
CCCM-24	77 x 64 x 77 ----- 30 x 25 x 30	20,000	101 / 46	145 / 66
CCCM-36	108 x 64 x 77 ----- 43 x 25 x 30	30,000	140 / 64	196 / 89
CCCM-48	138 x 64 x 77 ----- 54 x 25 x 30	40,000	185 / 84	251 / 114
CCCM-60	168 x 64 x 77 ----- 66 x 25 x 30	50,000	222 / 101	293 / 133



Comstock-Castle Stove Co. • 119 W. Washington St. • Quincy, IL. 62301  
Tel.: 217-223-5070 • Fax.: 217-223-0007 • Web: [www.castlestove.com](http://www.castlestove.com)

