

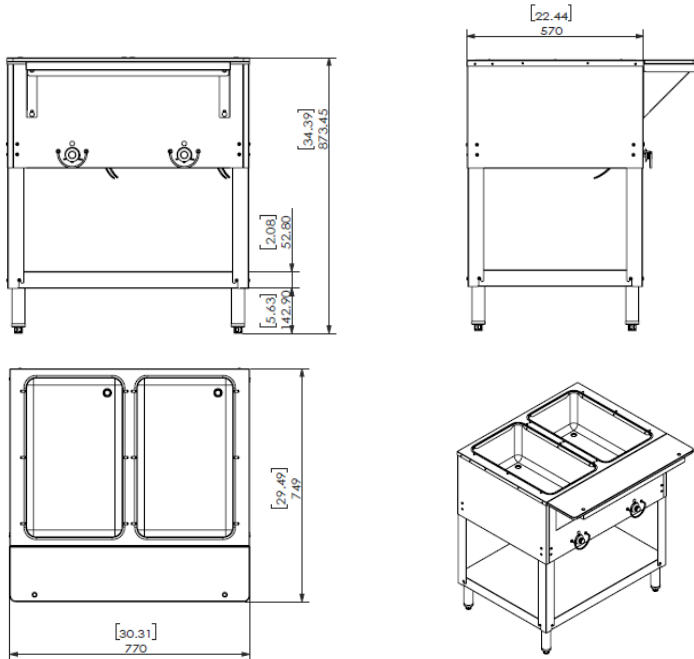

Est.1838 • Commercial Cooking Equipment

Electric Hot Food Table Sealed Well



Model CC-EHFT-SW-2-120



WARNING: This product can expose you to certain chemicals, which are known to the State of California to cause cancer or birth defects or other reproductive harm. For more information go to: www.P65Warnings.com



Standard Features, Benefits & Options

CONSTRUCTION: 30", 44", 58" & 72" wide models available. Easy cleaning, corrosion resistant stainless steel finish. Stainless steel legs and undershelf. 7" deep poly cutting board. Adjustable leveling bullet feet. Shipped KD.

TESTING: UL design & NSF Sanitation certified.

WELLS: Each stainless steel well is fully sealed and insulated. Sealed well hot food tables do not require any separate water pans so water can be added directly to the well. Individual well water drain valves.

ELEMENTS & CONTROLS: Each well features separate thermostatic controlled 120 volt heating elements with cool to the touch control knobs. A 6' cord with a NEMA 515P plug is included.

Model	Wells	Voltage	Watts	Hz	Phase	Package Size			Ship Weight	
						Width	Depth	Height	lbs.	Kg.
CC-EHFT-SW-2-120	2	120	1000	60	1	30.3"	29.5"	33.3"	90	41
CC-EHFT-SW-3-120	3	120	1500	60	1	45.7"	29.5"	33.3"	114	80
CC-EHFT-SW-4-120	4	120	2000	60	1	59.8"	29.5"	33.3"	145	65.5
CC-EHFT-SW-5-208	5	208	3750	60	1	74.0"	29.5"	33.3"	175	79

NOTICE: In an ongoing effort of product development & improvement, ComstockCastle reserves the right to change specifications and product design without notice. Such modifications do not entitle the buyer to corresponding changes or replacements for previously purchased equipment.



Comstock Castle Stove Co. • 119 W. Washington St. • Quincy, IL. 62301

