

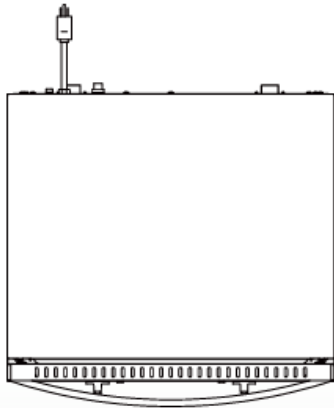

America's Oldest Stove Company
(Est. 1838)

CONVECTION OVEN

COUNTERTOP – HALF SIZE

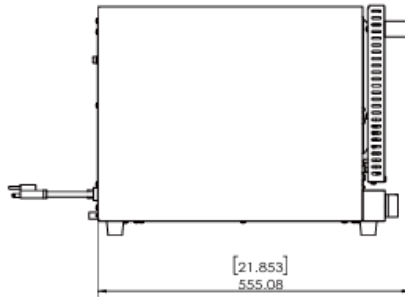
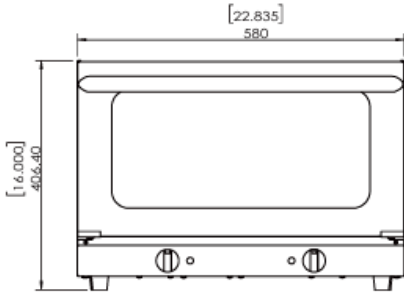

See website
for details

California Proposition



WARNING: This product contains chemicals known to the State of California to cause cancer and birth defects or other reproductive harm.

For more information visit: www.P65Warnings.ca.gov



NEMA
5-15P

Standard Features, Benefits & Options

CONSTRUCTION: Stainless steel construction for strength, durability and easy cleaning. 3, 13" x 18" chrome plated wire racks are included with capacity for 4 racks with 1 1/4" clearance between rack positions. 1" footers raise oven off countertops to allow insulating air underneath to reduce heat transfer. 1.5 Cu. Ft. oven capacity.

CONTROLS: Heat settings from 150-550°F. Fast preheat times. Durable fan circulates hot air evenly throughout the cooking chamber for consistent & even cooking results, ideal for small batches of baked goods, pizzas, hors d'oeuvres and other snack foods. NEMA 5-15P plug, 6' power cord.

DOOR: Double pane window for food product viewing. Vented door framing facilitates the cool to the touch door handle and control panel. High heat-resistant door gasket seals door frame for heat retention.

TESTING: cETLus Design certified. & ETL Sanitation listed complies to ANSI-NSF4 standards.

Model #	Frame Size: W x L x H
CC-O-E-CT-HS-120	23" wide x 22" x 16" tall

Model #	Voltage	Amps	Watts	Hz	Phase	Un-skidded Package Size			Ship Weight
						Width	Depth	Height	
CC-O-E-CT-HS-120	120	14.00	1600	60	1	26"	26"	19"	60 lbs.

NOTICE: In an ongoing effort of product development & improvement, Comstock-Castle reserves the right to change specifications and product design without notice. Such modifications do not entitle the buyer to corresponding changes or replacements for previously purchased equipment.



Comstock-Castle Stove Co. • 119 W. Washington St. • Quincy, IL. 62301
Tel.: 217-223-5070 • Fax.: 217-223-0007 • Web: www.castlestove.com





CC-O-E-CT-HS-120 schematic

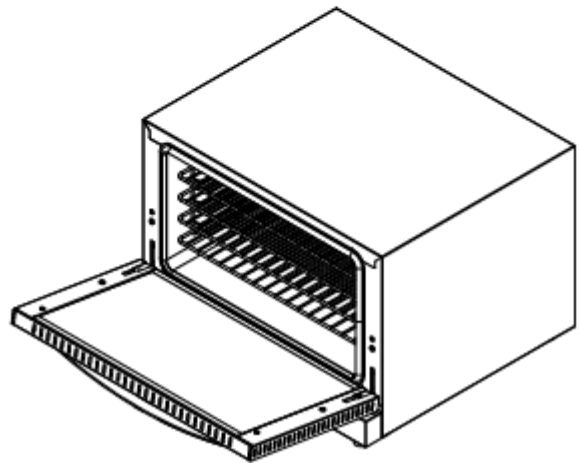
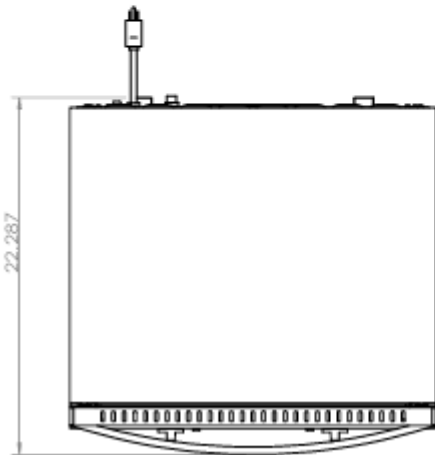
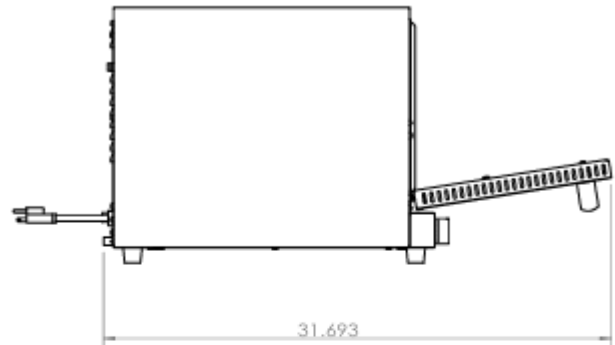
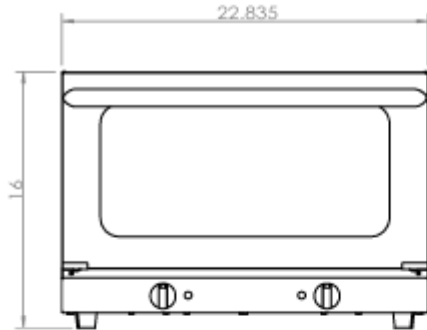

California Proposition



65 Warning

WARNING: This product contains chemicals known to the State of California to cause cancer and birth defects or other reproductive harm.

For more information visit: www.P65Warnings.ca.gov



NEMA
5-15P



Comstock-Castle Stove Co. • 119 W. Washington St. • Quincy, IL. 62301
Tel.: 217-223-5070 • Fax.: 217-223-0007 • Web: www.castlestove.com

