



Shallow Fryer

flat bottom



Model CC-2923



See website for details



California Proposition



65 Warning
WARNING: This product contains chemicals known to the State of California to cause cancer and birth defects or other reproductive harm.
 For more information visit: www.P65Warnings.ca.gov

Standard Features, Benefits & Options

CONSTRUCTION: Easy cleaning, corrosion resistant stainless steel front, side panels and tank. Adjustable legs for leveling. Special flue design reuses exhaust heat for efficiency.

FRY TANK: Stainless steel flat bottom fry vat spreads oil across a large horizontal surface area to create perfect conditions for floating food product like funnelcakes, doughnuts, beavertails, fried dough and churros as well as fried foods that require large surface areas like fish filets, tempura, samosas, bacalaito and chicharrones. 1" diameter grease drain valve with drain-pipe extension. 20" wide x 20" long wire lifting screen. Model CC-2923 features 20 to 30 lbs. fat capacity. An accompanying stainless steel tank cover doubles as a side drain board.

BURNERS: CC-2923 fryers feature (2) efficient steel burners each rated at 25,000 BTU's.

CONTROLS: 200° - 400° F Snap Action thermostat control for precise temperature control and faster recovery. Combination safety valve, pressure regulator. Double safety hi-limit control. Thermopile pilot system. ½" rear gas connection with ¾" adapter if needed.

TESTING: Optimal pressure is 4" WC for natural gas, 10" WC for propane. ETL design & ETL Sanitation (ANSI-NSF4) certified.

SPECS			
Model #	Frame Size W x L x H	Tank Size W x L	Ship Wgt.
CC-2923	23" x 27¾" x 19¾"	20" x 20"	150 lbs.

NOTICE: In an ongoing effort of product development & improvement, Comstock-Castle reserves the right to change specifications and product design without notice. Such modifications do not entitle the buyer to corresponding changes or replacements for previously purchased equipment.



Comstock-Castle Stove Co. • 119 W. Washington St. • Quincy, IL. 62301
 Tel.: 217-223-5070 • Fax.: 217-223-0007 • Web: www.castlestove.com





America's Oldest Stove Company
(Est. 1838)

CC-2923 schematic

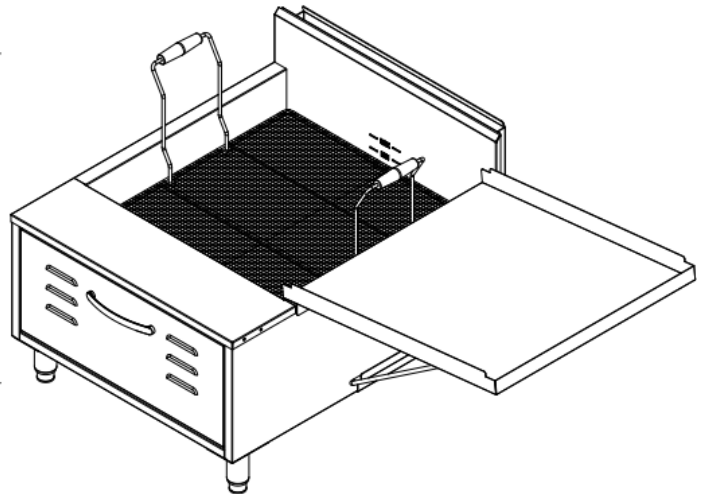
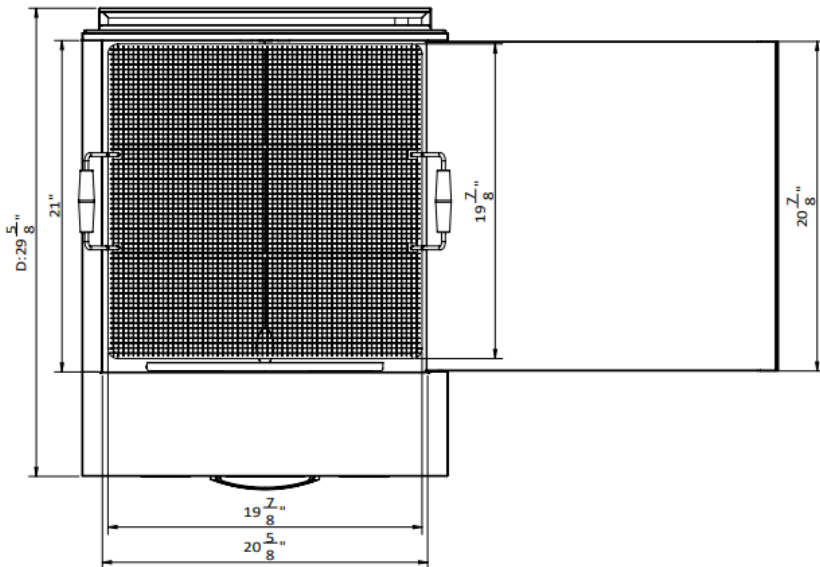
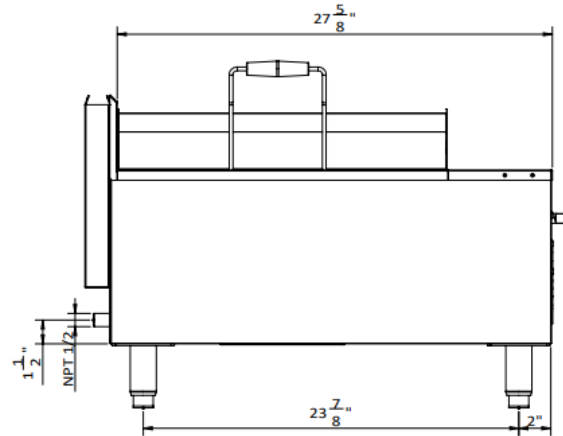
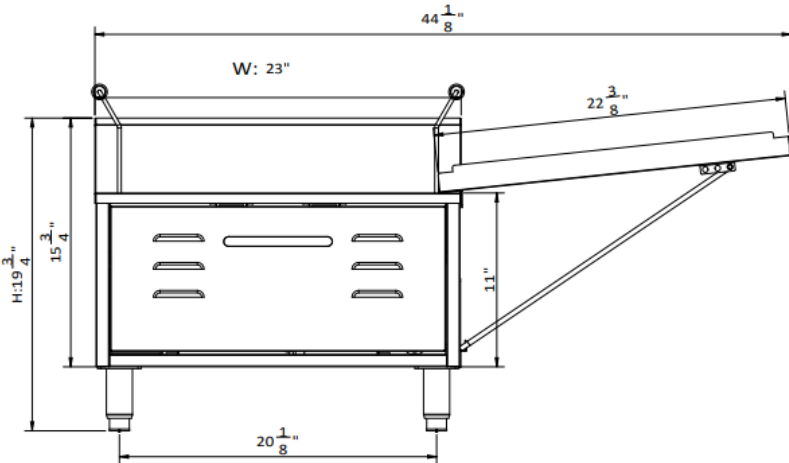

Comstock-Castle Stove Co. • 119 W. Washington St. • Quincy, IL. 62301
Tel.: 217-223-5070 • Fax.: 217-223-0007 • Web: www.castlestove.com

