



### Unit Information

Limited 2 Year Warranty  
 60Hz - 3.5 Amps  
 Hamilton Beach 901, 908 & 909  
 Jars Can Be Used On This Unit



## NuBlend 44 oz. Blender BB180X

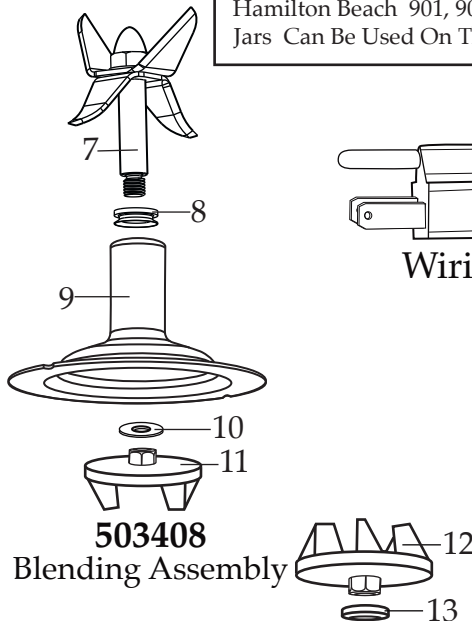
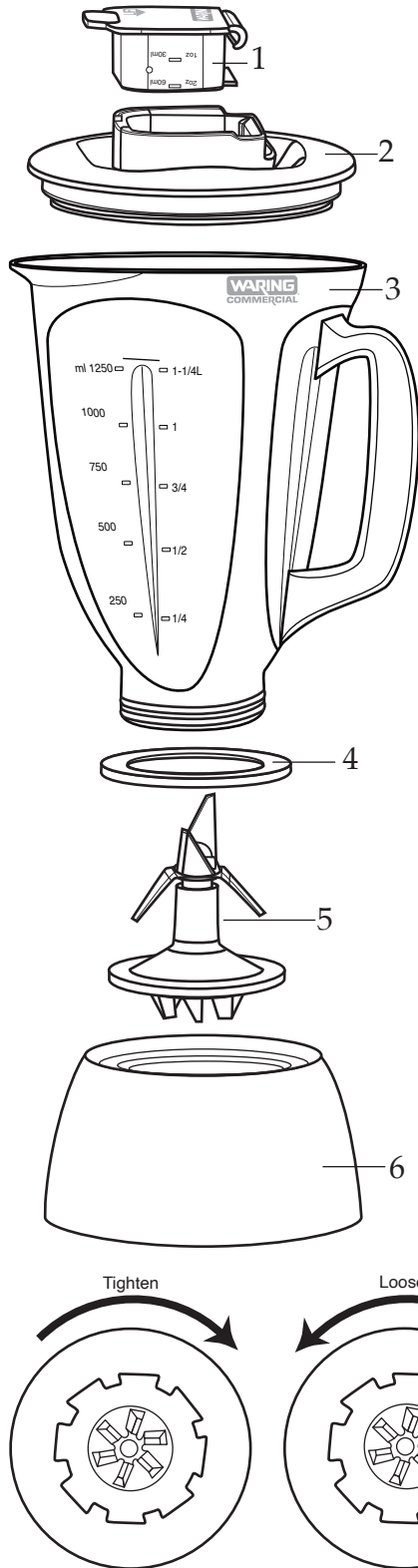

**503408**  
Blending Assembly



**013304**  
NSF Seal

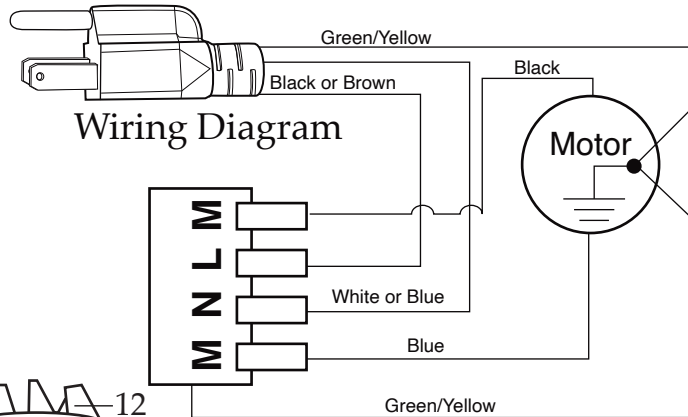
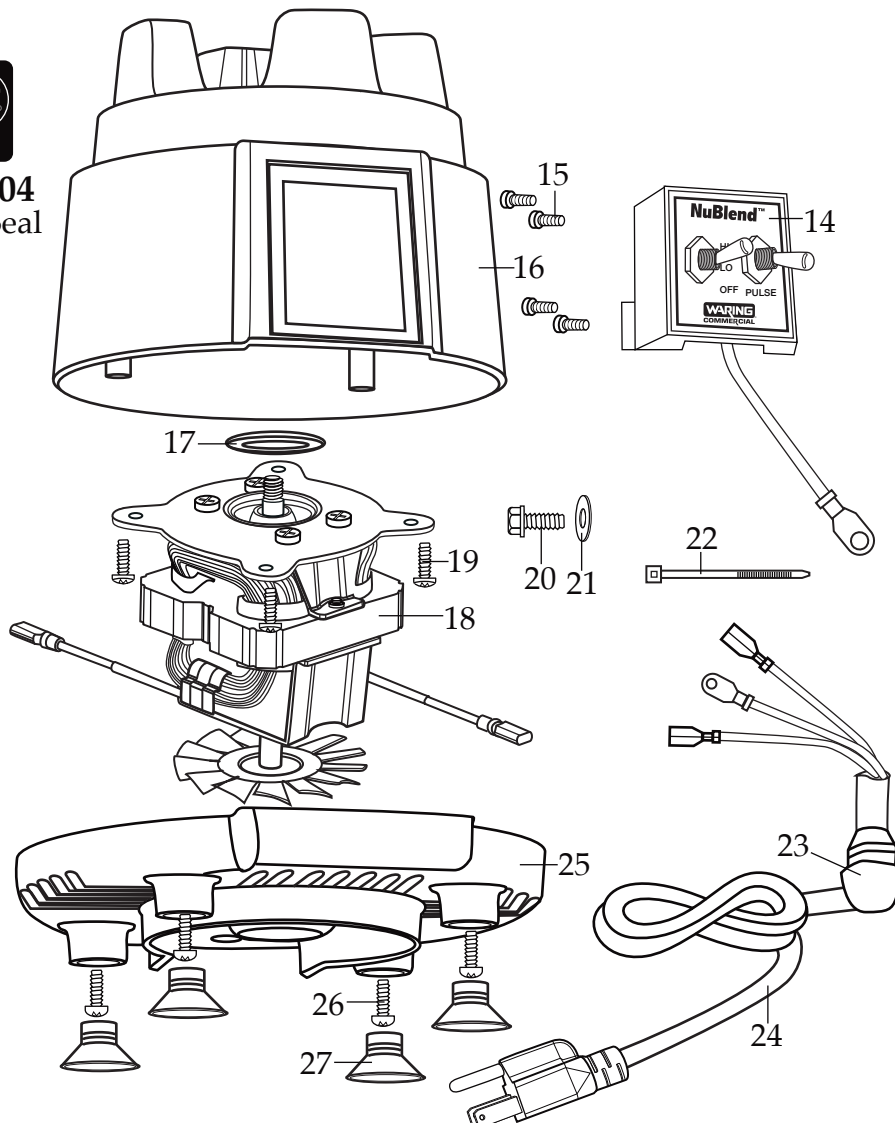

Jar Upside Down with Jar Bottom Facing You

Graphic by: Sandra A. Montysko

Revised August 12, 2021 Approved 8/12/2021

Page 1 of 2

Illustration#	Part#	Description
1	026282-E	Cover Lid
2	026281-V	Jar Lid
3	026280-E	44 oz. Eastman Container
4	026284	Jar Seal
5	503408	Blending Assembly
6	026285	Jar Bottom
7	503407	Blade Assembly
8	027716	V Seal
9	503358	Stainless Steel Bearing Holder
10	030426	Nylon Washer
11	032453	Coupling
12	032453	Coupling
13	035756	Cap Washer
14	503608 028209	Switch Assembly <i>(on units after 8/10/2021)</i> Switch Assembly
15	026267	Screw (4 required)
16	028212	Upper Housing
17	026269	Upper Motor Mount
18	035656	Chiaphua Motor with MTP
19	032611	Screw (4 required)
20	027278	Ground Screw
21	002943	Lock Washer (2 required)
22	013731	Cable Tie (2 required)
23	013680	Strain Relief
24	502835	Cord Set
25	028580-X	Bottom Housing
26	026276	Screw (4 required)
27	026278	Suction Cup Foot (4 required)