

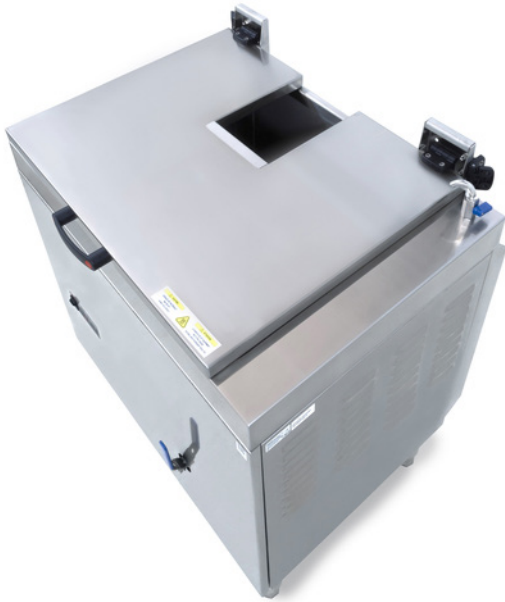

P/N. 1180414



## SALES DESCRIPTION

Large capacity tank with integrated hinged lid: maximum efficiency. Connected to and controlled by SmartVide XL.

Connected to and controlled by SmartVide XL to reach the set temperature faster.

- ✓ Connected to and controlled by SmartVide XL immersion circulator.
- ✓ Intelligent interaction allows for optimization of heating times.
- ✓ This is specially useful to cook very cold or frozen products.
- ✓ Stainless steel made.
- ✓ Complete with filling tap and drain key.
- ✓ The integrated hinged lid reduces steam emissions and improves energy consumption due to thermal management.

\* Please note: SmartVide immersion circulator must be ordered separately.

## SPECIFICATIONS

### Temperature

Display precision: 0.1°F

Range: 41°F - 203°F

### Time

Resolution: 1'

Cycle duration: 1' - 99 h

### General features

Maximum recipient capacity: 30 gal

Loading (120/60/1): / 3000 W

Loading (208-240/60/1): 3 Hp / 3000 W

### External dimensions (W x D x H)

External dimensions (W x D x H): 29.1" x 24.8" x 36.9-38.9"





# HEATED TANK 120P LID 208-240/50-60/1 · 120 L / 30 GAL



P/N. 1180414

FOOD PRESERVATION AND SOUS-VIDE  
SMARTVIDE SOUS-VIDE COOKERS

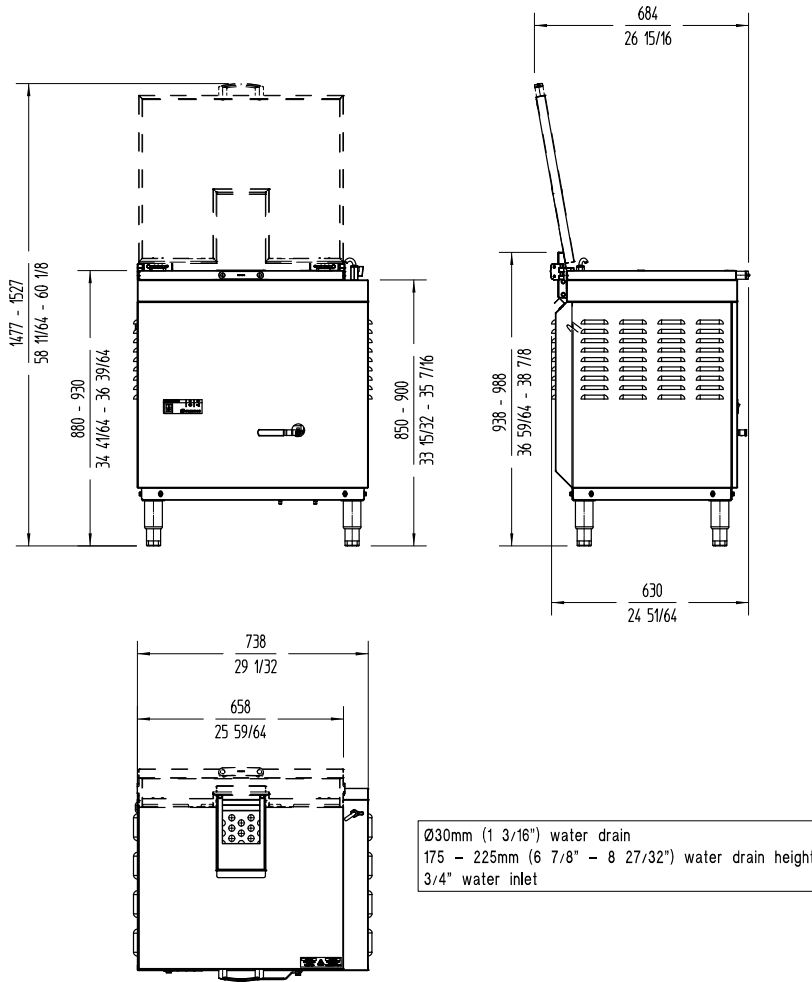

**sammic** | www.sammic.us  
Food Service Equipment Manufacturer

usa@sammic.com  
1225 Hartrey Avenue  
60202-1056 Evanston, IL

phone +1 (224) 307-2232  
toll free +1 844 275 3848



Project	Date
Item	Qty
Approved	

product sheet  
updated 01/14/25