



Model 35C+ & 45C+ Economy Tube Fired Gas Fryers



STANDARD ACCESSORIES

- Cabinet - stainless steel front, door
- Galvanized sides and back
- Tank - stainless steel
- Built-in integrated flue deflector
- Two nickel plated oblong, wire mesh baskets
- One nickel-plated tube rack
- One drain extension
- One drain line clean-out rod
- Removable basket hanger for easy cleaning
- 6" (15.2 cm) adjustable legs

AVAILABLE OPTIONS & ACCESSORIES

- Triple baskets
- Covers
- Fryer cleaner
- Casters

Project _____

Item No. _____

Quantity _____

STANDARD SPECIFICATIONS

CONSTRUCTION

- Welded tank with an extra smooth peened finish ensures easy cleaning.
- Long-lasting, high-temperature alloy stainless steel heat baffles are mounted in the heat exchanger tubes to provide maximum heating and combustion efficiency.
- Standing pilot light design provides a ready flame when heat is required.
- Cabinet front and door are constructed of stainless steel with galvanized sides and back.

CONTROLS

- Thermostat maintains selected temperature automatically between 200°F (93°C) and 400°F (190°C-CE).
- Integrated gas control valve acts as a manual and pilot valve, automatic pilot valve, gas filter, pressure regulator (MAX ½ PSI SUPPLY), and automatic main valve.
- Gas control valve prevents gas flow to the main burner until pilot is established and shuts off all gas flow automatically if the pilot flame goes out.
- Temperature limit switch safely shuts off all gas flow if the fryer temperature exceeds the upper limit.

OPERATIONS

- Front 1-1/4" (3.2 cm) NPT drain for quick draining.
- Standing pilot and thermostat maintain temperature automatically at the selected temperature (between 200°F (93°C) and 400°F (190°C-CE)).

Please note: 35C+ is only model "CE" approved

Model 35C+ & 45C+ Economy Tube Fired Gas Fryers



Model 35C+ and 45C+ Gas Fired Fryers

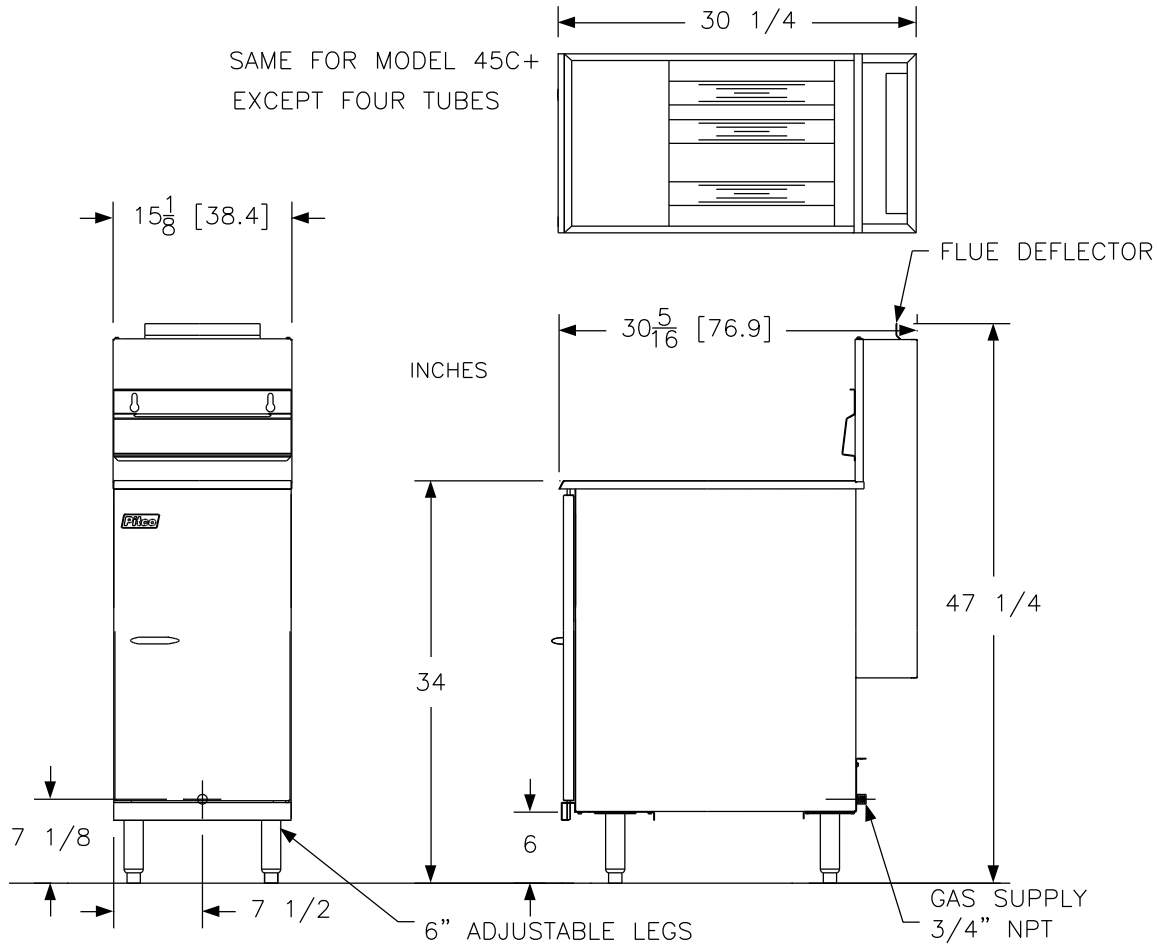

ELECTRICAL		OIL CAPACITY	
No Electrical options available		35-40 lbs (15.9 - 18.1 kg)- Model 35C+	
		42-50 lbs (19.1 - 22.7 kg)- Model 45C+	
SHIPPING INFORMATION (Approximate)			
161 lbs (73 kg) / 17.0 cubic feet (0.48 cubic meters) Model 35C+			
181 lbs (82 kg) / 17.0 cubic feet (0.48 cubic meters) Model 45C+			
GAS CONSUMPTION		PERFORMANCE CHARACTERISTICS	
90,000 BTU's/Hour (26.3 kW)		Cooks 50.2 lbs. (22.7 KG) of fries per hour.-Model 35C+	
122,000 BTU's/Hour (35.7 kW)		Cooks 66.2 lbs. (30.0 KG) of fries per hour.-Model 45C+	
Available in Natural or Propane Gas. For other Fuel types contact your Dealer/Distributor.			
Gas requirement for Incoming Pressure	NATURAL	PROPANE	
	7 - 9 inches	11 - 12 inches	
SHORT FORM SPECIFICATION			
Provide Pitco 35C+, or 45C+ tube-fired gas fryer. Fryer shall have an atmospheric burner system combined with three stainless steel tubes (Model 45C+ has four tubes) utilizing high temperature alloy stainless steel baffles. Fryer shall have a deep cool zone; minimum 20% of total oil capacity. Fryer cooking area shall be 14" x 14" (35.7 x 35.7 cm) with a cooking depth of 2-3/4" (7.00 cm). Model 45C+ has cooking depth of 4" (10.16 cm). Heat transfer area shall be a minimum of 588 square inches (3794 sq cm) for 35C+. Heat transfer area shall be a minimum of 785 square inches (5058 sq cm) for 45C+. Provide accessories as follows:			
TYPICAL APPLICATION			
Frying a wide variety of foods in a limited amount of space. Frying that requires a high volume production rate.			

