



JOB \_\_\_\_\_ ITEM # \_\_\_\_\_

# Step-Up Ranges



Model FSU330  
(shown with optional casters)

## Standard Features, Benefits & Options

**CONSTRUCTION:** Easy cleaning, stainless steel finish, sturdily welded with angle iron and corrosion resistant aluminized steel framing. High back splash and shelf is standard. Sturdy 6" stainless steel pipe legs with adjustable feet. Double wall construction with heavy fiberglass insulation assures heat retention for daily money saving fuel efficiency and offers the best installation clearances in the industry. Non-combustible surfaces are 0" on the sides and 0" in the rear, combustible surfaces are 2" on the sides and 2" in the rear.

**OPEN BURNERS:** 24,000 BTUH "star" pattern burners without gaskets is standard. The large 7" flame spread offers a more efficient burn pattern for small to large pots. Crumb trays catch all spillage. Top grates are 12" x 12" cast iron with a spillover bowl that also reflects heat for added efficiency. Stainless steel bullnose-rail is safely flush with the cook tops and functional to straddle pots, skillets and plates and also serves as control protection. The back burners are raised 4" above the front burners for easy skillet access to the back burner areas. Front burner height from the floor is approximately 36", the rear burners are approximately 40" from the floor.

**CONTROLS:** 500° thermostat, 100% safety oven shut off, automatic standing pilot and durable brass burner valves. Pressure regulators are set at the factory for the type of gas specified. Optimum pressures are 4" WC for natural gas and 11" WC for propane. Manifold size is 3/4" NPT. All controls are tested and confirmed in good working order. Calibration and installation adjustments are the responsibility of the buyer.

**OVENS:** 3 widths from which to choose; 31½", 26½" & 19½" All ovens measure 20½" deep x 14" high. One heavy duty chrome plated wire rack is standard with 3 rack positions spaced approximately 2¾" apart with 5¾" between the top rack position and the ceiling. Easy cleaning porcelain coated and aluminized steel oven linings are standard. The ovens feature a durable cast iron "H" pattern burner; 31½" & 26½" ovens are rated at 30,000 BTUH, the 19½" oven is rated at 25,000 BTUH. A special designed baffle directs heat for superior air circulation. Convection option is available, add prefix "C" to the model number.

**ACCESSORIES & OPTIONS:** Convection fan, extra oven racks, casters, pizza decks, safety pilot controls, lift off griddles, gas hoses and quick disconnects.





Comstock-CastleStoveCo. • 119W. Washington St. • Quincy, IL 62301  
Tel.: 217-223-5070 • Fax: 217-223-0007 • [www.castlestove.com](http://www.castlestove.com)

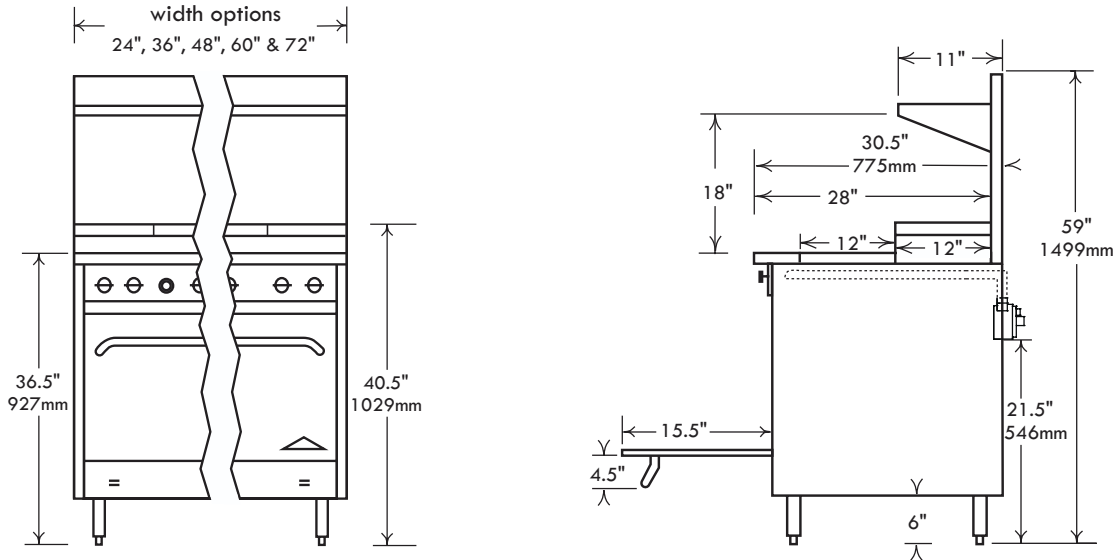

## STEP-UP RANGES MEASUREMENTS

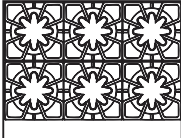

### Step-Up Ranges (Popular models shown below. Call factory for other model details.)

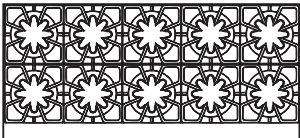
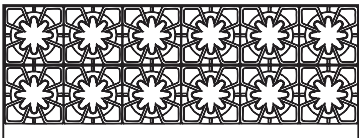
Cooktop Configuration	Model#	Description		Total B.T.U.	Approx. Wgt. Kg./Lbs.
		Top	Base		
	SUF318	(4) Open Burners	- w/ (1) 19.5" Oven	121,000	159 / 350
	SUF32	(4) Open Burners	- w/ (1) cabinet base	96,000	136 / 300
	SUF330	(6) Open Burners	- w/ (1) 31.5" Oven	174,000	227 / 500
	SUF33	(6) Open Burners	- w/ (1) cabinet base	144,000	193 / 425
	SUF3218	(8) Open Burners	- w/ (2) 19.5" Ovens	242,000	309 / 680
	SUF3430	(8) Open Burners	- w/ (1) 31.5" Oven	222,000	291 / 640
	SUF3226	(10) Open Burners	- w/ (2) 26.5" Ovens	300,000	418 / 920
	SUF33032	(10) Open Burners	- w/ (1) 31.5" Oven - & 22" storage space	270,000	355 / 780
	SU2F330	(12) Open Burners	- w/ (2) 31.5" Ovens	348,000	455 / 1000
	SUF33033	(12) Open Burners	- w/ (1) 31.5" Oven - & 34" storage space	318,000	373 / 820

Gas connection location as you look from the front: 21" from the floor, 3" from the left side.

NOTICE: In an ongoing effort of product development & improvement, Comstock-Castle reserves the right to change specifications and product design without notice. Such modifications do not entitle the buyer to corresponding changes or replacements for previously purchased equipment.

