



INSTALLATION • OPERATION MANUAL
for
COMSTOCK-CASTLE FOOD SERVICE EQUIPMENT

FOR YOUR SAFETY

Do not store or use gasoline or other flammable vapors or liquids in the vicinity of this or any other appliance.

WARNING

Improper installation, adjustment, alteration, service, operation or maintenance can cause property damage, injury or death. Read the installation, operating and maintenance instructions thoroughly before installing, operating or servicing this equipment.

NOTICE

Instructions must be posted in a prominent location that will provide the user of this equipment with procedures, in the event he/she smells and/or detects gas. This information must be obtained by consulting the local gas utility.

READ CAREFULLY AND KEEP FOR FUTURE REFERENCE!



NOTE: The equipment for which this Installation • Operation Manual is provided may be certified, have certification pending or not be certified under the standards of one or more of the following organizations: Intertek Testing Services (ETL) Please refer to the chart on page 3 for the status of each specific unit.

| CONTENTS: | PAGE NO. |
|---|-----------------|
| Definitions and Shipping Damage | 3 |
| General Information | 3-4 |
| Installation | 4-5 |
| Gas Connection & Conversion Procedure | 5 |
| Lighting Instructions | 5-8 |
| Calibration and Adjustments | 6-7 |
| Thermostat Calibration | 8-9 |
| Manual Pilot and Thermocouple..... | 9-13 |
| Preparation..... | 13 |
| Griddle Plate/Broiler Option | 13-15 |
| Lava or Radiant Broiler Option..... | 15 |
| Maintenance and Service Instructions | 15 |
| Drawings | 16-33 |
| Troubleshooting Chart..... | 34 |
| Comstock-Castle Warranty | Back Cover |

Comstock-Castle Stove Co. suggests that the user read this Installation/Operation Manual in its entirety before installing this equipment.

REMEMBER

Follow the instruction manual steps for installation.

Use a qualified gas technician for installation.

Check the unit every time you move for loose fittings and for being level.

Call the factory if you have any questions about installation or need the name of a qualified service/installation agent.

COMSTOCK-CASTLE STOVE COMPANY
 119 WEST WASHINGTON
 QUINCY, ILLINOIS 62301
 217-223-5070 (Voice)
 217-223-0007 (Fax)

www.castlestove.com

IN THE EVENT YOU SMELL GAS: Turn off gas supply. Open Windows, Do Not Touch Electrical Switches, Extinguish All Open Flame, and IMMEDIATELY CALL Your Gas Utility.

DEFINITIONS

QUALIFIED AND/OR AUTHORIZED OPERATING PERSONNEL

Qualified or authorized operating personnel are those who have carefully read this manual and are familiar with the functions of the equipment. Those who have had previous experience with the functions and operations of similar equipment should also read this manual to acquaint themselves with the unique characteristics of this equipment.

QUALIFIED INSTALLATION OR SERVICE PERSONNEL

Qualified Installation and/or Service Personnel are defined as those who, either in person or through a representative, are engaged in and are responsible for:

The installation or replacement of gas piping from the outside of the meter, (or service regulator when a meter is not provided), and the connection, installation, repair, or servicing of the equipment. Qualified personnel must be experienced in such work, be familiar with all precautions required, and be able to comply with all requirements of state or local authorities having jurisdiction. Reference: National Fuel Gas Code ANSI Z223.1-latest edition (NFPA Code 54).

SHIPPING DAMAGE CLAIM PROCEDURE

UNPACKING:

Inspect the crating for possible damage. Carefully remove the gas appliance from the crate and inspect the unit for concealed damage. (Perform applicable steps.)

1. Remove top grates and the range griddle plate if applicable.
2. Open oven door, remove rack(s), and oven bottom.
3. All packing material and burner tie down wire, if applicable, must be removed.
4. If stainless steel, remove the protective covering.
5. Properly install the legs or casters on the range.

NOTE: For proper operation and combustion, the legs or casters MUST be installed. 10 series, 11 series, & CFHP FHP1-2-3-4. SUFHP counter units do not have legs.

6. Locate the oven door handle and associated screws. Before mounting handle, clear the insulation around the mounting holes on the oven door. Using the two screws, mount handle to oven door.

Upon receipt and during installation of your new Comstock-Castle equipment, inspect it thoroughly for damage that may have incurred during shipment. If damage is evident, contact the carrier immediately.

FOR YOUR PROTECTION, IF SHIPMENT ARRIVES DAMAGED:

NOTE: FILE CLAIM FOR DAMAGES IMMEDIATELY, regardless of the extent of the damage. Time limits are in effect.

1. **VISIBLE LOSS OR DAMAGE** - Be certain this is noted on the freight bill or express receipt and signed by the person making the delivery.

2. **CONCEALED LOSS OR DAMAGE** - If damage is unnoticed until merchandise is unpacked, notify transportation company or carrier immediately, and file a "concealed damage" claim with them. This should be done within 15 days of the date delivery is made to you. Be sure to retain container for inspection.

Comstock-Castle cannot assume responsibility for damage or loss incurred in transit. Comstock-Castle will, however, be glad to assist you and furnish you with any necessary documentation to support your claim.

GENERAL INFORMATION

TO AVOID POSSIBLE INJURY, FIRE, and/or EXPLOSION, the following precautions must be read, understood, and followed explicitly.

CERTIFICATION STATUS * MINIMUM CLEARANCE

| Model | Combustible | | Non-combustible | |
|---------------------------|-------------|------|-----------------|------|
| | Back | Side | Back | Side |
| OVENS & RANGES | | | | |
| F3 Series (ETL) | 2" | 2" | 0" | 0" |
| FK4 Series (ETL) | 6" | 6" | 0" | 0" |
| P Series (ETL) | 6" | 6" | 0" | 0" |
| B Series (ETL) | 6" | 6" | 0" | 0" |
| HOT PLATES | | | | |
| FHP Series (ETL) | 5" | 4" | 0" | 0" |
| SUFHP Series (ETL) | 6" | 6" | 2" | 2" |
| KFHP Series (ETL) | 6" | 6" | 2" | 2" |
| CSP Series (ETL) | 6" | 6" | 4" | 0" |
| SP Series (ETL) | 6" | 6" | 4" | 0" |
| GRIDDLES | | | | |
| FHP Series (ETL) | 5" | 4" | 0" | 0" |
| 10 Series (ETL) | 6" | 6" | 0" | 0" |
| 9 Series | 6" | 6" | 0" | 0" |
| BROILERS | | | | |
| FHP Series (ETL) | 5" | 4" | 0" | 0" |
| 9 Series (ETL) | 6" | 6" | 0" | 0" |
| FRYERS | | | | |
| 2932SF (ETL) | 6" | 6" | 6" | 2" |
| J01HG (ETL) | 6" | 6" | 6" | 2" |
| 2616HG (ETL) | 6" | 6" | 6" | 2" |
| H Series | 6" | 6" | 6" | 2" |

All F3 and FK4 Series Ranges of this series are suitable for installation on combustible floors. Counter equipment is for use on non-combustible counters.

NOTE: The Model No. KFHP Series Hot Plates are not ETL Certified Designs.

All FHP Series, STFHP Series, and KFHP Series Hot Plates are for use in combustible and non-combustible locations when installed on a non-combustible counter.

The BTU input rating on all equipment is calibrated for elevations up to 2,000 feet above sea level. All orifice drill sizes are referenced for operation at or below this altitude. For operation at elevations above 2,000 feet, the BTU rating must be reduced 4% for each 1,000 feet of elevation or the orifice drill size must be changed appropriately. For high altitude drill sizes, call your local gas company or **Factory Authorized Service Center**.

All units are equipped with fixed orifices and cannot be adjusted. If converting the gas appliance from natural to propane, or vice versa, all orifices and the regulator must be changed. The correct type of gas, for which the unit is configured, is noted on the name plate. The type of gas specified **MUST** be used. For proper conversion, contact a qualified service technician or your **Factory Authorized Service Center**.

When installed with casters, adequate means of restraint must be provided to limit the movement of the appliance without depending on the connector and the quick disconnect device or its associated piping to limit the units movement. The restraint should be securely fastened to the back of the unit. If disconnection of the restraint is necessary, the restraint must be reconnected after the appliance has been returned to its original installation position.

For a gas appliance that is equipped with casters, the installation shall be made with a connector that complies with the Standard for Connectors for Moveable Gas Appliances, ANSI Z21.69 -1987, and addenda Z21.69a -1989, and a quick disconnect device that complies with the Standards for Quick Disconnect Devices for Use With Gas Fuel, Z21.69 latest edition and Z21.41 - latest edition.

Provisions shall be made in the design of the kitchen, to ensure an adequate fresh air supply for proper ventilation and combustion.

Do not obstruct the flow of combustion gases or ventilation air.

Never enclose the bottom of the unit with a raised curb and /or any other construction that would obstruct the air flow into unit.

One of the most important considerations in the installation of this unit is ventilation. A commercial gas appliance must be installed so that the products of combustion are efficiently removed. However, the kitchen ventilation system must not produce a draft that would interfere with the proper operation of the burners.

The area around this and any other appliance must always be kept free and clear of combustibles such as: grease, food particles, fuel, solvents, cleaning fluids, gasoline, mops, rags, and etc.

During installation, use thread compound sparingly. Always use a compound that is impervious to chemical reaction with propane gases. **NEVER** put any of the compound on the first two outer threads. This will minimize the possibility of the compound breaking free and clogging the pilots, burner orifices, and controls.

When a commercial gas appliance is first installed, the gas pressure must be checked with a manometer by a qualified service technician. This will ensure that the existing gas facilities will deliver the BTU's of gas required on the rating plate.

WARNING - If the appliance is configured for LP Gas, never connect the equipment directly to the pressure tank. Damage will result to the appliance if the tank pressure is not properly regulated. The regulator supplied with your unit is a low pressure (1/2 PSI max.) appliance regulator. For proper pressure regulation specifications, consult your local **Factory Authorized Service Agency** or an LP Gas Distributor.

INSTALLATION

THIS APPLIANCE IS INTENDED FOR OTHER THAN HOUSEHOLD USE

All Comstock-Castle commercial gas appliances are manufactured by skilled craftsman using the finest quality materials. PROPER installation by qualified personnel is essential for safe, efficient, and trouble-free operation of the unit. Any alteration and/or tampering, without proper knowledge, tools, and test equipment, is **DANGEROUS and will void all warranties.**

The installation must conform with local codes, or in the absence of local codes, with the National Fuel Gas Code, ANSI Z223.1 - latest edition.

PRESSURE TESTING:

FAILURE TO INSTALL PRESSURE REGULATOR WILL VOID WARRANTY. (Most units have a convertible regulator.)

The appliance and its individual shut-off valve must be disconnected from the gas supply piping system during any pressure testing of that system at test pressure in excess of 1/2 psig (3.45 kPa).

The appliance must be isolated from the gas supply piping system by closing its individual manual shut-off valve during any pressure testing of the gas supply piping system at test pressures equal to or less than 1/2 psig (3.45 kPa).

NOTICE

The proper installation of this gas appliance is the total responsibility of the end user.

It is the responsibility of the purchaser to determine that the installer is qualified in installation procedures. Conversion, connecting gas lines, calibrating thermostats, burners, lighters, setting gas pressure with manometer, and etc., is all part of normal installation and will not be paid for under warranty. If a warranty technician is called out and finds the unit improperly installed, the end user may be subject to billing.

FOR MAINTENANCE, SERVICE, REPAIRS, OR INSTALLATION - Contact your dealer or the factory, for your local **Factory Authorized Service Agency**.

INSTALLING THE BACKSPLASH OR HIGH SHELF:

To install a backsplash or high shelf on a Comstock-Castle Range, proceed as follows:

1. Ensure back of unit is easily accessible.
2. If mounting low back (backsplash), slide into supports on back of unit, and secure with #10 x 5/8" sheet metal screws.
3. If mounting high shelf, mount shelf to high back using #24 x 3/4" machine screws with nut and washer.
4. Slide backsplash into the side-supports on back of unit, and secure with #10 x 5/8" sheet metal screws. (Fig. 1)

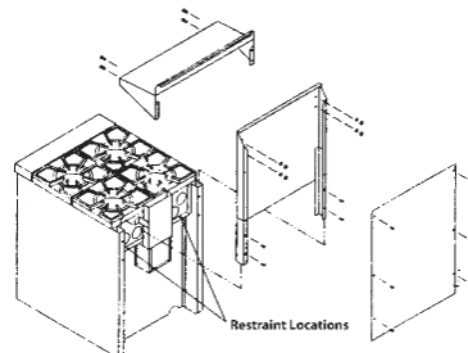

Figure 1

HOOK-UP PROCEDURE FOR COMBINATION UNITS:

Units prefixed with a "2" may be shipped separately. For connection, set the units side by side. Install backslash. Install hook-up strip in the front center of the two units. Ensure that everything is aligned properly. Install and tighten all screws.

GRIDDLE PLATE INSTALLATION:

Griddle plate front trim must be placed under the plate rest to prevent plate from moving. Rear of plate must be lifted to allow front edge under the plate rest. If unit is equipped with thermostat, sensing bulbs need to be installed under the plate prior to placing front trim under plate rest.

GAS CONNECTION & CONVERSION PROCEDURE

GAS CONNECTION:

The size of the gas line is extremely important. If the line is too small, the gas flow in the manifold will be low. This inadequate flow will cause slow recovery and delayed ignition. If in doubt about the proper size of your service line, consult your local gas utility company.

DO NOT connect appliance before testing the pressure of the gas service supply piping system.

FOR NATURAL GAS - Fixed orifices are set at 4" W.C. (water column). If a pressure regulator is supplied, it must be installed when the unit is connected to the gas supply.

FOR PROPANE GAS - Fixed orifices are set at 10" W.C. (water column). If a pressure regulator is supplied, it must be installed when the unit is connected to the gas supply.

Pressure regulator must be tested in a full condition (all valves "ON"). A condensation/paniculate trap must be provided in the supply line, with a separate shut-off valve upstream of the regulator. These items are customer installation responsibilities.

Your Comstock-Castle appliance is equipped with a 3/4" NPT entrance pipe. Level the appliance under station exhaust hood and connect the gas line from the service gas shut-off valve to the inlet side of the gas pressure regulator using 3/4" pipe. DO NOT use a domestic type gas flexible connector. If a flexible or semi-flexible connector is used, an AGA Certified Flexible Connector with an inside dimension equal to 3/4" must be used. Always avoid sharp bends that could restrict the gas flow to the appliance. All piping must be installed in accordance with local codes, or in the absence of local codes, with the National Fuel Gas Codes: ANSI Z223.1 latest edition - NFPA No. 54.

IMMEDIATELY CHECK the plumbing with a concentrated soap solution or an approved gas detector. Coat all joints associated with the gas distribution system. Bubbles indicate leaks and the appliance MUST NOT be operated until the leak is corrected. NEVER use an open flame to test for leaks. Be sure to check all gas connections with the main burner "ON" and "OFF". Check and, if necessary, adjust the manifold pressure.

GAS CONVERSION:

A qualified service technician must be used to safely convert the appliance from natural gas to propane gas, or vice versa. The regulator, burner orifices, pilot orifices, and possibly the pilot lighter bar orifice, if applicable, must be converted. The appliance must be retested for proper alignment, calibration, and gas pressure.

Caution: Never attempt conversion when the unit is hot! For all manually and thermostatically controlled equipment:

If a regulator has been shipped with the unit, it MUST be installed properly. If not factory installed, connect regulator with arrow pointing in the direction of gas flow. Use thread compound sparingly. **NOTE: DO NOT APPLY** thread compound to the female threads of any part.

Some larger models may have two gas inputs for the manifold system. If this is the case, all gas inputs to the unit MUST have a factory approved regulator.

IMPORTANT NOTICE FOR UNITS WITH CONVERTIBLE PRESSURE REGULATORS

PROPANE GAS CONVERSION INSTRUCTIONS

A griddle is equipped with fixed orifice hoods and shipped from the factory for use on natural gas. To convert to propane gas, install the propane burner orifice hoods supplied as follows:

1. Remove the griddle plate by lifting with two people and set aside.
2. Slide the burners back off of the valve orifice hoods a couple of inches and let it rest.
3. Remove the natural gas orifice hoods with a 1/2" wrench.
4. Apply a very little bit of pipe dope on the threads of the valve. DO NOT APPLY PIPE DOPE INTO ORIFICE HOOD.
5. Attach the supplied propane burner orifice hoods with a 1/2" wrench.
6. Convert the pressure regulator from Natural to Propane gas by inverting the snap-in device beneath the cap on the regulator. This will require a fair amount of pressure. Do not remove the spring. When replacing the cap make sure the snap-in insert goes down on top of the middle of the spring. (Fig. 2)
7. Test for proper pressure; 10" W.C. (water column) using a manometer.
8. Slide burners back onto the orifice hoods.
9. Apply the Propane "Notice" sticker to the front of the unit for future reference.

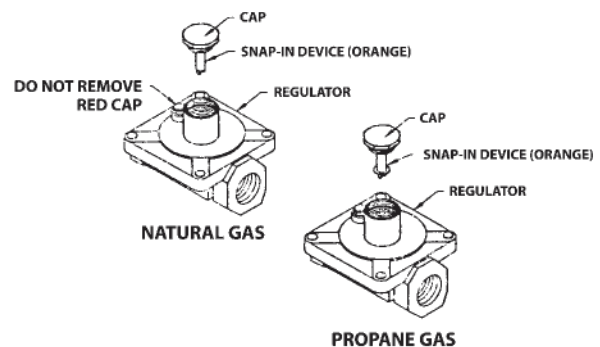

Figure 2

LIGHTING INSTRUCTIONS

NOTE: While lighting a manual pilot system, sufficient time must be allowed for the proper pilot flame to heat the thermocouple that will hold the safety valve open. If lighting for the first time, allow some time for air to be purged from the gas distribution system.

TO LIGHT THE CHINA HAT PILOTS: (OPEN TOP BURNERS)

1. The main gas valve should be "OFF" for at least five minutes to allow any accumulated gas to escape the combustion chamber.
2. Remove spider rings, open top grates, and locate the pilots.
3. Turn supply gas "ON" and hold match close to the pilot head. The pilot should light.
4. Turn the manual gas control to the "ON" position. The main burners should light.

TO TURN THE CHINA HAT PILOTS OFF:

1. Turn the supply gas control to the "OFF" position and ensure all burners are off.

NOTE: Pilots cannot be shut off unless the main gas supply to the appliance is shut off.

TO LIGHT THE OVEN PILOT:

Remove the lower kick panel below the oven door. Open oven door and remove the oven rack. Remove oven bottom.

1. The Robertshaw Grayson TS11J safety valve or BASO H15HR-2 should be closed for at least five minutes to allow any accumulated gas to escape the combustion chamber.
2. Turn the thermostat to the lowest possible setting.
3. Depress and hold down the red button while lighting the pilot. Hold the button down for about 45 seconds.
4. Release the red button. The pilot should stay lit.
5. Set the thermostat to the desired temperature. The main burners should light.

TO TURN OFF THE OVEN PILOT: (See Fig. 3)

1. Turn the thermostat to the lowest possible setting.
2. Blow out pilot. The safety valve will automatically shut off the gas supply system.

TO LIGHT THE GRIDDLE: (Thermostatically Controlled Griddles)(Optional)

For units that are equipped with a thermostatically controlled griddle, proceed as follows:

1. The Robertshaw Grayson TS1U and BASO H43A safety valve should be closed for at least five minutes to allow any accumulated gas to escape the combustion chamber.
2. Turn the thermostat to the lowest possible setting.
3. Depress and hold down the red button while lighting the pilot through the pilot hole. Hold the button down for about 45 seconds.
4. Release the reset button. The pilot should stay lit.
5. Set the thermostat to the desired temperature. The main burners should light.

TO TURN THE GRIDDLE OFF:

1. Turn the thermostat to the lowest possible setting.

2. Blow out pilot. The safety valve will automatically shut off the gas supply system.

TO LIGHT A STANDING PILOT: (Manually Controlled Griddles)

1. The main gas control valve should be "OFF" for at least five minutes to allow any accumulated gas to escape the combustion chamber.
2. Sight pilot head through the pilot sight hole on front of apron.
3. Turn on the main gas and hold a match close to the pilot head. The pilot should light.
4. Turn the manual gas control to the "ON" position. The main burners should light.

TO TURN THE STANDING PILOT OFF:

1. Turn the manual gas control to the "OFF" position and ensure all burners are off.

NOTE: Pilots cannot be shut off unless the main gas supply to the units is shut off.

CALIBRATION AND ADJUSTMENTS

IMPORTANT: Calibration and adjustments are part of normal installation and are NOT subject to billing under warranty.

TO CHECK AND ADJUST THE MANIFOLD PRESSURE:

All units must be tested for proper manifold pressure at the time of installation.

Proceed as follows:

NOTE: MUST be performed ONLY by qualified service personnel. Contact your **Factory Authorized Service Agency**. Call the factory for the nearest agent.

1. Ensure the gas control and the main gas line is in the "OFF" position.
2. Locate and remove the NPT pressure tap plug.
3. Insert the proper fitting for a gas pressure measuring device into the tap hole and connect the measuring device to the fitting. (Manometer preferred).
4. Turn on gas and light all burners. With all burners operating, monitor the gas pressure reading for the correct pressure. For proper and efficient operation, the pressure reading must be 4" W.C. for natural gas; 10" W.C. for propane gas.
5. If necessary, remove the cap on the regulator and adjust the manifold pressure for the correct pressure as indicated on the pressure measuring device on units with adjustable Reg.

NOTE: Turning the adjustment screw clockwise will increase the output pressure and counterclockwise will decrease the output pressure. Not all units have adjustable Reg.

6. ALWAYS ensure the cap is replaced on the regulator.
7. Turn the gas and the unit "OFF" and reinstall the pressure tap test plug.
8. Ensure the top of the regulator is kept clear of dust and fluids as these will clog the regulator vent port.

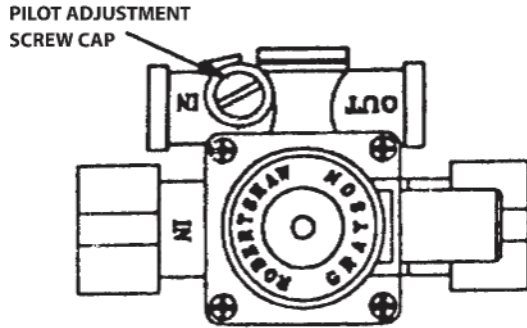

Figure 3
Robertshaw Grayson TS11J Safety Valve

APPLICATION

The H43 valve is designed to provide safe lighting and complete shutoff of pilot and main burner gas. An interlock between the manual valve handle and the reset button allows gas flow only to the pilot during pilot lighting. The control shuts off both main and pilot gas if the pilot flame is extinguished. The manual valve controls both main and pilot gas.

H43 valves are suitable for use with natural gas, Liquefied Petroleum (LP) gas, and LP gas-air mixtures at pressures up to 35 mbar (0.5 psi). Models H43_A with a standard power unit are suitable for operation over a temperature range of 0 to 80°C (32 to 175°F). Models H43_B with a high temperature power unit are suitable for operation over a temperature range of 0 to 120°C (32 to 250°F).

DESCRIPTION

The H43 valve contains a plug valve with multiple drillings, which allows it to serve as both the main burner valve and pilot valve. The valve handle indicates the operating position. Safe lighting is accomplished by a positive interlock between the valve handle and reset button, which allows for resetting the valve to the pilot position only. The handle incorporates a lock button to prevent accidentally turning off the valve. The lock button must be lifted to permit turning the plug valve to the Off position. The main burner may be throttled between the On and Pilot position through the use of the handle.

In the event of pilot flame outage, gas is shut off both to the main burner and pilot burner. The handle must be turned to the Pilot position to reset the valve and light the pilot burner. The pilot outlet is located on the right-hand side of the valve casting, when looking into the inlet of the control with the reset button up. The pilot connection is 1/4 cc. It flows toward the inlet of the control and is regulated with a pilot adjustment screw. The pilot connection is also available with the flow toward the outlet of the control. (Contact BASO Gas Products.)

MOUNTING

H43 valves may be mounted in any convenient position with the reset button and manual valve handle accessible.

DIMENSIONS

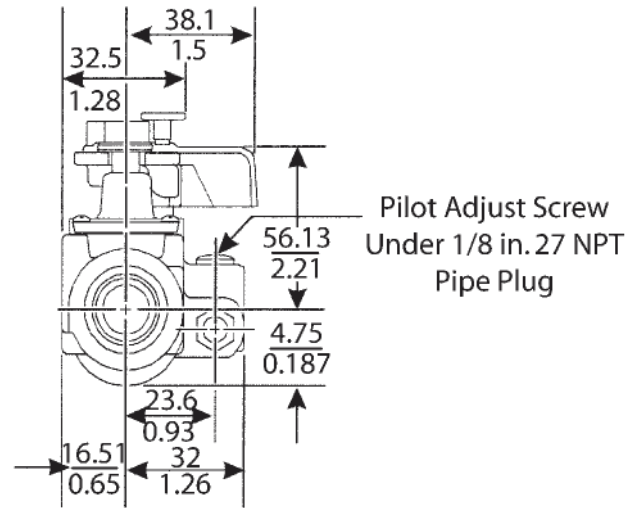
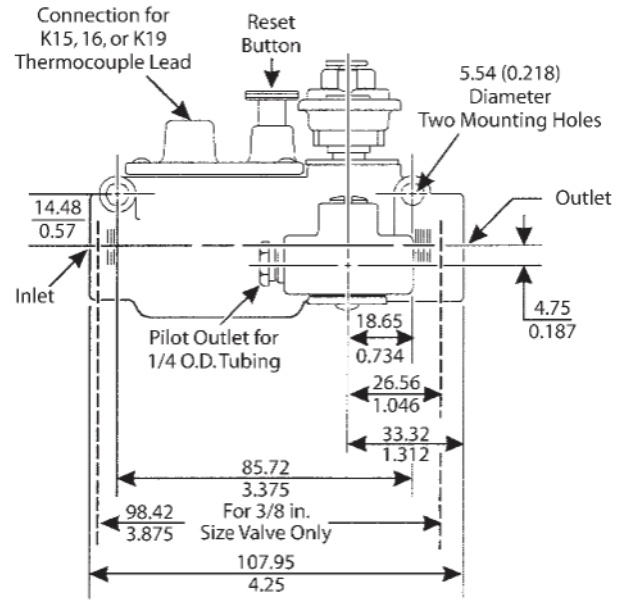

Dimensions, mm (in.)

PILOT ADJUSTMENT:

SAFETY PILOT ADJUSTMENT PROCEDURE: (Fig. 4)

NOTE: All Comstock-Castle appliances that are designed with safety valves, are equipped with a pilot adjustment key.

For use with ovens and thermostatically controlled griddles:

1. Remove knobs, control panel, oven rack(s), and the oven bottom.
2. Locate the pilot adjustment screw cap on the safety valve and remove the cap.
3. Turn the slotted pilot key to provide the proper size pilot. (See Fig. 3, TS11J Safety Valve or BASO H43A).
4. Replace the pilot adjustment cap.
5. If equipped with BASO H15HR-2 the pilot adjustment is made with a fitting in the Back-out Pipe.

STANDING & CHINA HAT PILOT ADJUSTMENT
PROCEDURE: (Fig. 5)

NOTE: Caution must be exercised during the initial installation and/or conversion of standing or china hat pilots to ensure that the pilot valves are not wide open.

1. The main gas valve should be "OFF" for at least five minutes to allow any accumulated gas to escape the combustion chamber.
2. Gently remove the control knobs and the front apron panel to the unit.
3. Remove spider rings, open top grates, and locate the pilots.
4. Follow the pilot feed tube back to the manifold and locate the pilot adjustment valve.
5. With a small flat-tipped screwdriver adjust the valve to its minimum position, (maximum clockwise)
6. Ensure that the thermostat or manually operated controls are in the "OFF" position.
7. Turn on the gas. While holding a match close to the pilot head, slowly open the pilot valve (counter-clockwise) until the pilot head lights.
8. Properly adjust pilot flame for the correct height.
(See Fig. 5)

NOTE: A properly adjusted pilot will NOT cause pilot/burner infringement, flame lift, or excessive carbon.

9. Properly adjust all the pilot valves. Ensure all pilots will easily ignite each burner.
10. Replace the front apron panel and knobs.
11. Replace top grates, spider rings, and proceed with "BURNER ADJUSTMENT".

Safety pilot

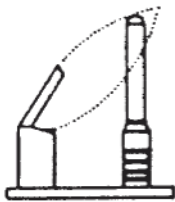

Figure 4
(Robertshaw 2C-1)



Figure 5
(Pilot)

BURNER ADJUSTMENT:

(For oven, griddle, and open top burners)

NOTE: All Comstock-Castle appliances are equipped with fixed orifices and the burners cannot be adjusted for gas flow. The only adjustment necessary is the primary air adjustment. A blue flame is necessary for proper combustion and maximum efficiency. Check for proper operation after cleaning the unit. It is recommended this adjustment be done at least once or twice a year.

1. Ensure the unit is shut off and cooled down.
2. Remove all knobs and the front apron panel from the unit.
3. Loosen screw on the air mixer which is located on the venturi section of the burner.
4. Light the burner and set control for maximum "ON". Allow the burner to burn at least five minutes.
5. Open air mixer until flame starts to float from the main burner ports.
6. Slowly close air mixer until the flame settles softly on the burner ports. The flame should now be a well-defined blue with no yellow tips.
7. Carefully tighten the screw and ensure the flame has not changed.
8. Replace apron and knobs, proceed to "THERMOSTAT CALIBRATION".

THERMOSTAT CALIBRATION

NOTE: When Comstock-Castle griddles are equipped with a Robertshaw thermostat, they are carefully calibrated at the factory. If calibration is needed, it is recommended that ONLY a qualified service technician perform the adjustment.

BY-PASS ADJUSTMENT: (minimum burner flame)

When the cooking area reaches the temperature to which the thermostat dial is set, the control will cut down the flow of gas that is needed to keep is at the selected temperature. The control must always by-pass enough gas to keep the entire burner lit. The by-pass must always be carefully and accurately adjusted to maintain the minimum flame.

NOTE: If the by-pass is in need of adjustment, it is recommended the ONLY a qualified service technician perform the adjustment.

1. Light and adjust the pilot. Check and, if necessary, adjust the manifold pressure.
2. Turn the dial completely "ON", to light the burner.
3. Wait five minutes, turn and set the dial to a point slightly below the first mark on the dial.
4. Carefully remove the dial and the bezel.
5. Locate the by-pass adjustment screw and monitor the burner flame height. With a screwdriver, turn the by pass adjustment screw counter-clockwise to increase the height of the flame and clockwise to decrease the height of the flame. The adjustment must maintain a minimum flame over the entire burner. The minimum flame should be approximately 1/8" in height.
6. Replace the bezel and the dial, rotate the thermostat dial unit it locks in the "OFF" position.

THERMOSTAT CALIBRATION: (See Fig. 6)

NOTE: Once the appliance is properly installed, all thermostats associated with the equipment must be checked for proper calibration. The thermostat is a precision instrument and is carefully calibrated at the factory. Field calibration is seldom needed and should not be attempted unless a considerable amount of experience proves that the control is not maintaining the dial set temperature. If calibration is needed, it is recommended that **ONLY** a qualified service technician perform the adjustment.

NOTE: Always ensure the by-pass flame is properly adjusted prior to any attempt to recalibrate.

To check for proper temperature during test or recalibration, always use an accurate test instrument with the proper sensing device. This will ensure the correct temperature is being recorded. On all griddle plates, use a disc probe and drop a few drops of oil on the plate. Place the disc probe into the oil flat against the griddles surface.

When placing the sensing probe in the oven, always ensure the oven probe hangs freely approximately at the center of the oven. Do not permit the probe to touch the sides or the racks of the oven.

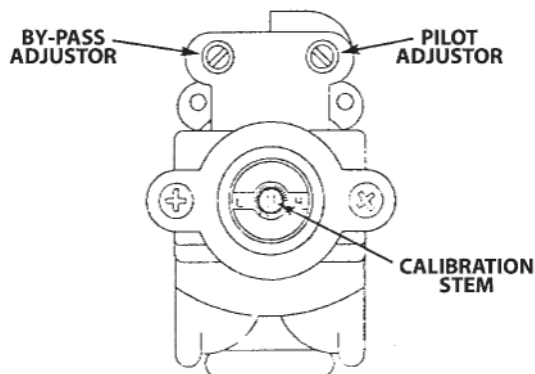

Figure 6
Robertshaw BJWA Thermostat

CALIBRATION STEPS:

1. Remove the thermostat dial and pull out the metal insert.
2. Replace the thermostat dial and set the dial to the 350 degree mark. Light unit.
3. Light oven and allow a sufficient amount of time for the temperature to stabilize (approximately 15 minutes).
4. Check temperature at five minute intervals until two successive temperature readings are within 5 degrees of each other.

NOTE: If the control does not read within 10 degrees of the dial setting (350 degrees), the control should be recalibrated. For recalibration proceed as follows:

5. Hold thermostat dial firmly, insert a screwdriver through the center of the dial and push on the calibration stem. **CAUTION:** DO NOT turn the stem.

6. While firmly holding the calibration stem in, turn the dial to the actual temperature shown on the test instrument. Release the pressure on the calibration stem and remove the screwdriver. Replace the dial insert.
7. Set the temperature control dial to 400 degrees. Once again, check the temperature as instructed in steps 3 & 4. If the temperature is not within 10 degrees with a dial setting of 400 degrees, then the sensing element is inoperative and the control should be replaced.

Fryer Thermostat Calibration

1. Remove front cover of valve with Phillips screwdriver.

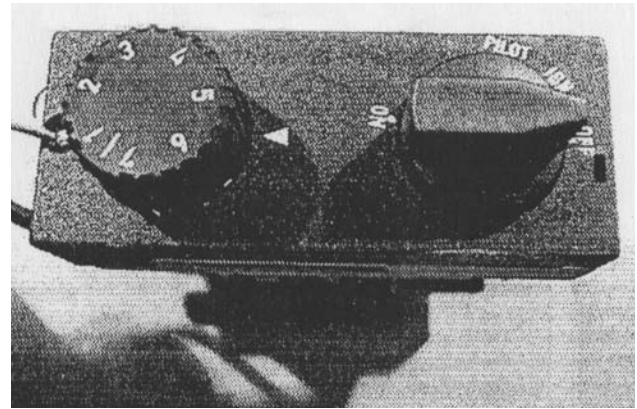

2. Remove knob by using flat screwdriver.

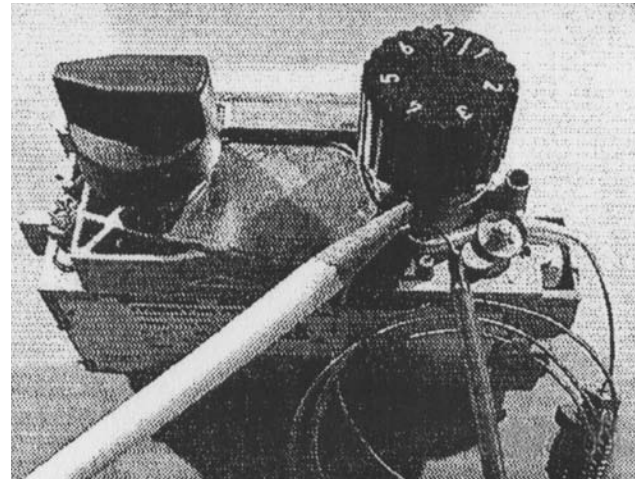

3. To increase temperature, turn brass knob counterclockwise. Turn knob slowly until burner kicks on and wait for it to shut off, check temperature, adjust until temperature reaches approx. 395 at #7.

MANUAL PILOT SYSTEM

When heat is applied to the thermocouple, a voltage is produced that will energize the magnetic head in the safety valve. When the pilot flame is extinguished, the voltage produced by the thermocouple will decrease. Thus, both the pilot and the main gas will be shut off at the safety valve.

TROUBLESHOOTING THE MANUAL PILOT SYSTEM

PROBLEM: (Pilot will not stay lit.)

1. Check for drafts that could blow out the pilots.
 2. Ensure the pilot has a sharp blue flame. If not, clean pilot orifice. **CAUTION:** Be careful not to enlarge or distort the pilot orifice when cleaning.
 3. Make sure thermocouple is properly seated in the safety valve (finger tight plus 1/4" turn with a wrench).
- NOTE:** DO NOT over-tighten, damage could result to the safety valve.
4. Check pilot adjustment, adjust if necessary.
 5. Have a qualified service technician properly test pilot system to determine and correct the problem.

TO REMOVE AND REPLACE THE THERMOCOUPLE:

1. Remove all items needed to gain easy access to the pilot head assembly.
2. Unscrew thermocouple lead in pilot head.
3. Unscrew thermocouple lead from safety valve and remove the thermocouple.
4. To replace the thermocouple - reverse the above procedure and test.

THERMOCOUPLE VOLTAGE RANGE: Comstock-Castle equipment may be configured with the following. In the event of a failure, replace with an identical component only!

Robertshaw thermocouple part #T46. Manufacturer suggested operational voltage range, 18 to 24 milivolts.

NOTE: DO NOT over-tighten (finger tight plus 1/4" turn with a wrench).

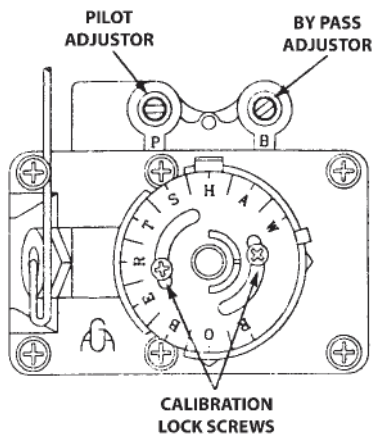

Figure 7
Robertshaw FD Thermostat

TO CALIBRATE THE ROBERTSHAW FDH, FDL, & FDO OVEN THERMOSTAT FOR FRYERS, PIZZA AND BAKE OVENS:

1. Place the sensing probe of the test instrument in the middle of the oven.
2. Light main burner and set the temperature dial to 400 degrees. Allow the oven to heat until the burner flame cuts down to by-pass. Check temperature on the test instrument. If temperature does not read within 10 degrees of the dial setting, recalibrate as follows:
3. Without turning, pull dial straight off.
4. Hold the calibration plate and loosen the calibration lock screws until the plate can move independently of the control.
5. Turn the calibration plate so that the reading on the test instrument is in line with the indicator mark. Hold plate firmly and tighten screws.

Safety Warning Instructions

FOR MERTIK MAXITROL GV30 SERIES GAS COMBINATION CONTROLS

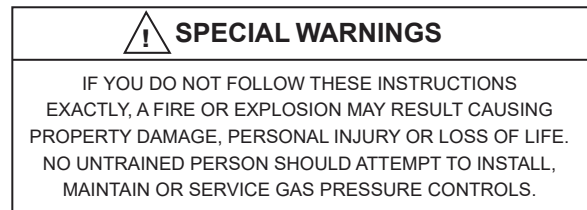

To minimize the possibility of FIRE, EXPLOSION, and OTHER HAZARDS.

1. All products, including gas pressure controls, used with combustible instructions of the manufacturer, with government codes and regulations, and plumbing codes and practices.
2. Do not use a gas combination control if it appears to have been subjected to high temperatures, damaged in any way, or to have been taken apart or tampered with. Any of these may be signs of possible potentially dangerous combustion problems.

3. Installation

- a. Turn off gas supply before starting installation.
- b. Install the control properly so gas will flow as indicated by the arrow on the casting.
- c. Make sure markings or wording on control are not painted over or obliterated.

Mounting positions (see diagrams below)

- d. The gas control can be mounted horizontally 0 to 90 degrees in any direction from the upright position, i.e. from the position when the knobs are on top. It can also be mounted in a vertical position.

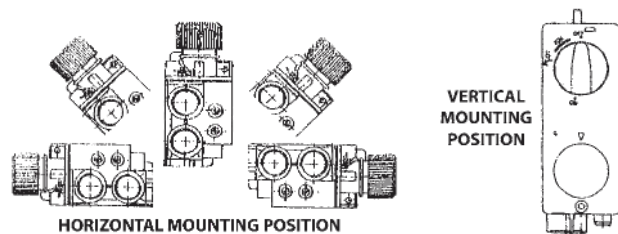

Main gas NPT connections (inlet or outlet)

- e. Use joint compound/thread sealant, properly threaded pipes and careful assembly procedure so that there is no cross threading, etc., which can cause damage or leakage.

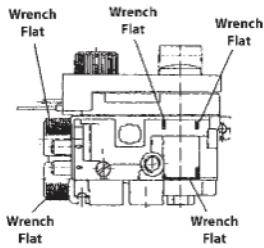

Figure 1

- f. Apply light pressure only at wrench flats (see Figure 1) to avoid damage to control body, which can result in leakage or malfunction of control. Do not apply pressure to top casting or plastic cover.

Main gas (outlet only) and/or *side outlet tubing connection

- g. Square off end of tubing and remove burrs.
- h. Slip gland and ferrule over tubing.
- i. Insert tubing into the outlet until it bottoms, slide ferrule and gland into place and turn finger tight. Do not use joint compound.
- j. Use a wrench to tighten gland about one turn beyond finger tight. (*if side outlet model, do not rotate outlet in its threads to avoid possible leakage.)

Pilot gas connection (tubing only)

- k. Square off the end of tubing and remove burrs.
- l. Slip compression fitting over tubing. Insert tubing into pilot outlet connection until it bottoms, slide fitting into place and turn finger tight. Do not use joint compound.
- m. Use a wrench to tighten fitting about 1-1/2 turn beyond finger tight.
- n. Connect other end of tubing to pilot burner according to the manufacturer's instructions.

| |
|--|
|  CAUTION |
| DO NOT BEND TUBING AT GAS CONTROL AFTER COMPRESSION FITTING HAS BEEN TIGHTENED, AS THIS MAY RESULT IN GAS LEAKAGE AT THE CONNECTION. |

Thermocouple connection

- o. The gas control has an electrical thermocouple connection and must therefore be kept clean and dry; joint compound should never be applied to it. Tighten only 1/4 turn beyond finger tight in order to make a good electrical connection. When mounting the thermocouple tubing, do not bend it too sharply (min.radius 25 mm).

Bulb Location and Mounting

- p. Temperature sensing element is to be located and mounted by the OEM and is not to be changed without consulting factory or qualified serviceman. The temperature sensing element should be placed in a location representative of desired temperature. Never place directly in flame.

- 4. Check carefully for gas leaks immediately after the control has been installed and the gas turned on. **Do this before attempting to operate the appliance or other gas burning device.** Use a rich soap solution (or other accepted leak tester) to check all flanges, knobs, joints, and piping connections. Wipe clean with a damp rag. It is a good practice to periodically check for leakage during use of the appliance. **Absolutely no leakage should occur, otherwise there is a danger of fire or explosion depending upon conditions. Never use if leakage is detected.**

| |
|--|
|  CAUTION |
| NEVER CONNECT CONTROL DIRECTLY TO THE PROPANE SUPPLY SOURCE. LP APPLICATIONS REQUIRE AN EXTERNAL REGULATOR (NOT SUPPLIED). INSTALL THE EXTERNAL REGULATOR BETWEEN THE PROPANE SUPPLY SOURCE AND MERTIK MAXITROL CONTROL. |

- 5. Adjustments and Final Checkout

| |
|---|
|  WARNING |
| ADJUSTMENTS MUST BE MADE BY QUALIFIED PERSONS ONLY. BEFORE ADJUSTMENTS CAN BE MADE, THE COVER SHOULD BE REMOVED. IF THE APPLIANCE MANUFACTURER SUPPLIES CHECKOUT AND/OR SERVICE AND MAINTENANCE INSTRUCTIONS, CAREFULLY FOLLOW THEM. IF THESE INSTRUCTIONS ARE NOT PROVIDED THEN USE THE FOLLOWING PROCEDURE. |

Removing cover

- a. Unscrew the cover at the side of the thermostat knob.
- b. Put a small screw driver in the slotted hole at the side of the operation knob and lift the cover.

Pilot flame adjustment

- c. Combination control is shipped with pilot flow at maximum.
- d. Refer to the pilot burner manufacturer's instruction for recommended size of pilot flame.
- e. If adjustment is required, turn the pilot adjustment screw clockwise to decrease or counterclockwise to increase pilot flame.

Outlet pressure adjustment (a gauge capable of reading inches w.c. is required for any outlet pressure adjustments)

- f. Remove cover to expose pressure regulator adjustment screw.
- g. Bring unit to high fire (all burners on maximum). Slowly turn adjustment screw with a small screwdriver until the required burner pressure is recorded on the pressure gauge. Turn adjustment screw clockwise to increase or counterclockwise to decrease gas pressure to main burner.

*Side-outlet manual valve minimum flow adjustment

- h. Combination control is shipped with the side-outlet manual valve set at maximum flow. If adjustment is required perform step g., and then set the manual valve knob (knob-C, Figure 2) to the minimum position. Turn side-outlet manual valve minimum adjustment screw (Figure 2) clockwise to decrease flow.

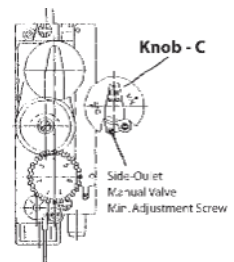

Figure 2
(Shown with cover)

(*Do not rotate side outlet in its threads to avoid possible leakage.)

- i. Replace cover.

Final checkout of the installation

After any adjustment, set appliance in operation. Observe several complete cycles to ensure that all burner components function correctly.

6. Operation

Basic operation

Knob-A (Figure 3) for manual pilot, on-off function, and piezo activation. Knob-B (Figure 3) for temperature level selection with intergrated thermostat providing snap action(on-off) and modulation control for minimum to maximum flow.

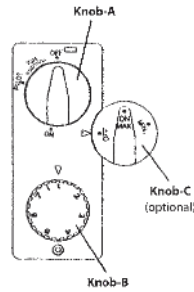

Figure 3
(Shown with cover)

Ignition intrlock

The interlock device prevents the re-establishment of gas flow – when no pilot flame is present – until the thermocouple has cooled sufficiently.

Adjusting temperature

Turn knob-B (Figure 3) toward higher numbers to increase temperature, toward lower numbers to decrease. Remote control versions contain a motor that activates this knob, or it can also be operated manually.

Optional side-outlet control for 2-burner operation

Additional side-mounted manual valve (knob-C, Figure 3) primarily for 2-burner gas fireplace applications.

Lighting procedure

- a. Turn knob-A (Figure 4) slightly left towards the 'IGN' position until reaching stop, press down and hold for five seconds (only pilot gas flows).
- b. Continue pressing down while turning further left to activate piezo, continue to hold down for 10 seconds after pilot burner has been lit. If pilot does not light, steps a. and b. can be immediately repeated. (See Note below)
- c. Upon lighting, release knob and turn further left to 'ON' position (both pilot and main gas flows).

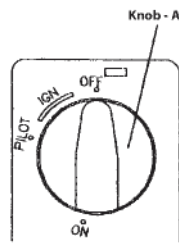

Figure 4

Note: If pilot flame is not established, equipment manufacturer (OEM) will determine the number of additional attempts to light – and with continued failure the purge time.

Shut off procedure

- a. Turn knob-A (Figure 4) right until reaching stop.
- b. Press down slightly and continue turning right from 'PILOT' position to the 'OFF' position.

When the thermocoupler has cooled sufficiently (time will vary based on themocouple type used), pilot lighting procedure can be repeated. (See Ignition interlock.)

7. Very high pressure surges in the gas supply line (or as a result of exposing the system to high pressure) may result in serious internal damage and cause leakage or affect control operation. If you suspect tht a Mertik Maxitrol control has been exposed to more than 1-1/2 times its maximum inlet pressure, turn off the gas and have the system checked by an expert.

8. The outlet pressure of the control **must** be measured to make sure it is in accordance with intended usage.

9. Caution should be used to guarantee that there is sufficient inlet pressure to achieve the desired outlet pressure and no readjustment of the outlet pressure setting should be made unless the inlet pressure is within the proper limits for the control. Failure to follow this may result in overfiring of the appliance or other gas burning device.

10. A Mertik Maxitrol combination control must be used within its ambient temperature range, and not in excess of its maximum inlet pressure. The control can be used with all fuel gases.

11. In case of any doubt, please contact the Service Manager, Maxitrol Company, Southfield, MI. Phone: 248/356-1400.

12. Specifications

Maximum Operating Inlet Pressure

1/2 psig (34.5 mbar)

Ambient Temperature (Control)

32° to 176° F (0 to 80° C), or 32° to 225° F (0° to 107° C) for "T" Models

Control Range

Capacity: 10,000 – 85,000 BTU/hr
 Outlet Pressure: 3" w.c. to 5" w.c. (7.5 to 12 mbar)
 8" w.c. to 12" w.c. (20 to 30 mbar)

*Piezo & Cable

Min/Max Spark Gap: 3/4 mm
 Min/Max Operating Temperature: -4° to 392° F (-20° to 200° C)
 Min/Max Lead Lengths: 150/1000 mm

(*Piezo wire **should not** be drawn down parallel against lengths of metal –this can result in reduction or loss of power to ignitor. When placing the ignition cable/piezo wire, care should be taken not to stretch it too tightly. If possible, **avoid** contact with the appliances's metal parts, especially those with sharp edges.)

Maximum Ambient Temperature (Sensor)

Control Range 55° – 95° F: Sensor 122° F (50° C)
 Control Range 60° – 120° F: Sensor 160° F (71° C)
 Control Range 85° – 175° F: Sensor 230° F (110° C)
 Control Range 210° – 640° F: Sensor 715° F (380° C)

Hardwired Wall Switch

Use 24 gauge wire or larger for a maximum run of 100 feet

Ultrasonic Remote Control and Receiver

Receiver wire to combination control is rated at 350° F
 Optimal remote operating distance 20 feet
 (For best results use fully charged ALKALINE batteries in ambient temperatures less than 125° F)



WARNING

USE CAUTION WHEN LEAVING AN OPERATING
MOTORIZED CONTROL UNATTENDED.
ALTHOUGH UNLIKELY, RANDOM SONIC SOUNDS
COULD SIGNAL THE ULTRASONIC RECEIVER AND
ACTIVATE THE VALVE — LOWER KNOB 'B' COULD
ROTATE AND CAUSE THE MAIN BURNER TO COME ON,
OR THE FLAME HEIGHT TO ADJUST.

PREPARATION

Transite Stone Break-In Procedure:

If the oven is configured as a Pizza Oven, the racks used are called transite stones. These stones will naturally draw moisture, and will crack if not properly treated.

WARNING: DO NOT clean stones with high abrasion brushing or water as they may crack! Liquids should NEVER come in contact with the stones! Wipe clean with a dry rag!

INSTALLING THE TRANSITE SHELVES:

1. Once the oven has been properly installed, slide the stone into the guide.
2. To minimize warpage and maximize the life of the stones, it is strongly recommended that they be predried. First, preheat the stones with the pilot burner on for one hour. Then over a five hour period gradually increase the temperature 100 degrees an hour to achieve baking temperature, then allow one hour to elapse to complete the procedure.
3. A slight odor and outgassing may occur during the initial heat up. This is normal as the stones are adjusting to their environment.
4. The stones should be reversed periodically to equalize wear.
5. DO NOT wedge stones together! The stones must be installed un-restrained with approximately 1/8" joint space for every 24" of deck to allow for expansion. Mechanically fastened stones or those installed tightly are subject to cracking!

GRIDDLE PLATE/BROILER OPTION

BREAK-IN PROCEDURE:

IMPORTANT: A rust inhibitor has been coated on the griddle surface to protect it during shipment and storage. This rust inhibitor MUST be removed from the griddle plate prior to placing the unit in service.

1. Wash thoroughly with a mild detergent and rinse with ample clean water.
2. Thoroughly dry the griddle plate with a soft rag, then place it securely on the body, with front of trough under plate rest on F Series.
3. Cover plate with table salt and saturate with cooking oil.

4. Light burners. Adjust the flame to the lowest setting possible. Maintain a low flame setting for one hour.
5. Allow the plate to cool, then wipe off residue with a clean cloth.

GRIDDLE OPERATING SUGGESTIONS & CAUTIONS:

- Always allow sufficient time to ensure that the temperature of the plate is up to the desired temperature before using.
- NEVER over heat the griddle plate and always reduce the temperature during idle periods.
- Always clean griddle plate after use and coat plate with a light coat of cooking oil.
- For cleaning, griddle pads and griddle bricks may be used on steel plates ONLY.
- As a sanitary and safety precaution, always keep the grease drawer clean and empty.
- If griddle plate is placed in storage, cover and store in a dry location. If stored for any length of time, saturate plate with a coat of lard to prevent rusting.

OPEN TOP BURNER OPERATION:

9 & 10-11 SERIES (Non-Certified Equipment)

If your new Comstock-Castle Counter Griddle contains an open top burner section, the unit is referred to as a "Combination Griddle". This unit will be configured with a cast iron burner base that incorporates a stainless steel or aluminum burner ring.

FOR PROCEDURES REFERENCE THESE SECTIONS:

- STANDING PILOT LIGHTING
- STANDING PILOT ADJUSTMENT
- BURNER ADJUSTMENT

BROILER OPERATION - 9 & 10-11 SERIES (Non-Certified)

If your new Comstock-Castle Counter Griddle contains a Broiler/Griddle combination, the unit is referred to as a "Combination Griddle". This appliance is identified by the letter "B" following the model number. Unlike the standard griddle model, this unit will be equipped with one or more burners fitted with a specially designed flame spreader. This flame spreader directs heat down for broiling purposes.

MANUALLY OPERATED BROILER/GRIDDLE:

When broiling is desired, turn the manual control completely counter-clockwise for initial power up. Always reduce the setting, to a lower operating temperature after the initial high heat setting. Operating the unit at this high heat setting for longer than 15 minutes could discolor the griddle top.

Always remember when heat is applied to the broiler, heat is also being applied to the griddle plate.

ALL BROILER VALVES WILL NEED TO BE REGREASED DUE TO HIGH OPERATING TEMPERATURES.

FRYER LIGHTING INSTRUCTIONS

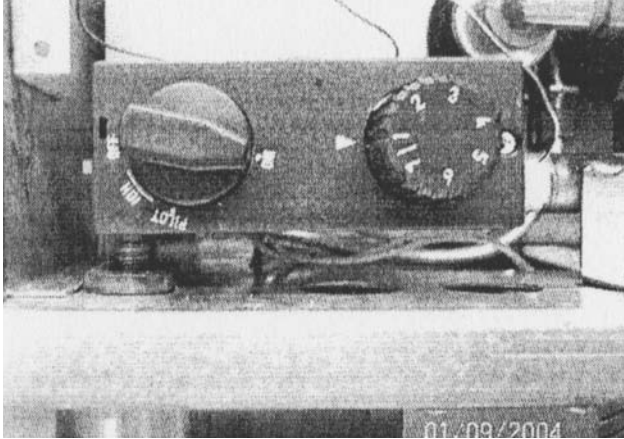

NOTICE: When turning on the gas at the propane tank, turn gas on very slowly. Turn valve just a small amount. This allows the gas to get into the lines without shutting the tank regulator down. The regulator on the tank should have a safety feature that is designed to sense a leak. After lighting pilot, open tank valve a few turns.

1. Turn knob to pilot position.
2. Push knob in.
3. Light pilot while holding knob in.
4. Hold knob in for 30-60 seconds while thermocouple heats up. (May take longer at initial set up to purge lines.)
5. Release knob, check to see if pilot stays on.
6. Turn knob to ON position.

APPROXIMATE TEMPERATURE FOR KNOB SETTINGS

| | |
|------------|-----|
| #1 Setting | 240 |
| #2 | 260 |
| #3 | 286 |
| #4 | 315 |
| #5 | 335 |
| #6 | 361 |
| #7 | 397 |

SPECIAL INSTRUCTIONS FOR SHALLOW FRYER

Comstock-Castle's model 2923SF, 2932SF and 2941SF is designed as a shallow, large surface area fryer. This fryer is designed for use in permanent locations operating on natural or LP gas.

Model 2923SF, 2932SF and 2941SF can be used in mobile operations, but, due to the nature of these types of operations, special consideration should be given. Please follow the installation manual supplied. if you have any installation questions at all, please call us at 217-223-5070. Follow the pilot lighting and thermostat calibration instructions in the manual. Many people think they can successfully install gas appliances because they have a pipe wrench and make a leak-free connection - this is not the case.

There are many other factors to keep in mind, more so in a mobile operation. Many people think they do not need a pressure regulator on the appliance as well as on the tank. This is not true! There should always be a tank regulator on the tank and an appliance regulator on each gas appliance due to each appliance's distinctive operation pressure. Giving an appliance too much or too little gas pressure can cause operation and performance problems.

When installing, you should use a manometer to check and set the appliance to the designed operation pressure. Model 2923SF, 2932SF, 2941SF is designed to operate at ten (10) inches water column (WC) for LP gas. Make sure you fill the tank with oil or water whenever you run the burners. four (4) inches water column when operation on natural gas.

For adjustments, if needed, follow instructions 1 and 2 .

1. Pilot Flame Adjustment

Combination control is shipped with pilot flow at maximum. Refer to the pilot burner manufacturer's instruction for recommended size of the pilot flame. If adjustment is required, turn the pilot adjustment screw clockwise to decrease or counterclockwise to increase pilot flame.

2. Outlet Pressure Adjustment (a gauge capable of reading inches W.C. is required for any Outlet Pressure Adjustments)

Remove cover to expose pressure regulator adjustment screw. Bring heater to high fire (all burners on maximum). Slowly turn adjustment screw with a small screwdriver until the required burner pressure is recorded on the pressure gauge. Turn adjustment screw clockwise to increase or counterclockwise to decrease gas pressure to main burner.

Once you have set the unit at 10 inches W.C., turn off all the appliances and shut off the gas supply. Remove the manometer. When you install the pressure regulator, it is preferable to use pipe sealer on the threads. Do not get sealer on the last few threads. This keeps the sealer from drying, then breaking off inside the pipe and plugging fittings and controls.

Whenever the equipment is moved or shut down, make sure you follow the lighting instructions. If the thermostat or regulator is struck, they may be knocked out of adjustment and need to be recalibrated.

In a mobile operation, please keep in mind that every time the unit is moved, you should check the pilot and, of particular importance, check that the unit is as level as possible. If you are in a trailer, perhaps you can make adjustments to the trailer for each site. The legs on the 2323SF, 2932SF, 2941SF have adjustable feet and can be used to level the unit. You want the unit to be slightly higher in the back than in the front. This allows combustion air to more easily be drawn in the front and exhausted by the rear flue. If the unit is out of level with the front higher than the back, the combustion may flue out the front and destroy the safety valve and makes for less operator comfort.

Do not place a fan so the air blows directly at the front of the unit or down the flue. Also, avoid locations that have natural draft blowing into the unit or down the flue. These drafts will cause pilot

problems and when the pilot goes out, The entire unit shuts down and must be relit. Never place anything on top of the flue!! the 2923SF, 2932SF, 2941SF is designed to operate with the front door in place. The front door is removeable for cleaning, servicing and draining, but should be kept on during operation.

Keep the interior of the unit as clean as possible. Keeping the controls and burners clean and free of grease will allow them to burn clean and perform as required.

LAVA OR RADIANT BROILER OPTION

During initial installation, cover the bottom of the broiler firebox with one or two layers of volcanic rock. For cooking, turn the valves full on and preheat the unit for about 15 minutes. Then adjust the burner flame height as desired for broiling. Broiling with volcanic rock is like broiling with charcoal. Various meat densities and sizes will require different temperature settings and cooking times. This can be affected by adjusting the valves. Install radiants with smaller on outside of firebox, than large-small-large...across width of firebox.

Residual grease on the radiant grates and/or volcanic rock should be burned off after use or prior to next use. Turn the valves on full for 15 minutes or until all the grease is burned off from the previous broiling. Never cover top grate with pans when heating.

MAINTENANCE AND SERVICE INSTRUCTIONS

Like any other piece of equipment, the unit must be cleaned on a regular basis.

CAUTION: FOR YOUR PROTECTION: This is commercial cooking equipment. It should be kept in mind that when in operation, the surface temperature will exceed that of equipment designed for household use. Always maintain the proper clearance as specified in the table cited under General Information.

If the unit is restrained, the operator should be aware of how the unit is restrained. The operator should be familiar with how to connect and disconnect the restraints. If the restraint is removed for service or maintenance, the restraint must be reconnected prior to putting the unit back into service.

NEVER attempt to move or slide the unit when hot. ALWAYS let the unit cool down and empty the grease drawer prior to any attempt to relocate or move the unit. NEVER move or transport the unit when the unit is hot.

TO CLEAN THE EXTERIOR: (Stainless Steel)

1. Let it cool down. Normal daily soil can be removed with a mild detergent or soap solution applied with a damp cloth. Rinse and dry thoroughly.
2. To remove baked-on grease, apply a cleanser in the direction of the polish lines on the metal. NEVER rub in a circular motion. Scotch Brite or Stainless Steel scouring pads may be used on tough or burnt-on deposits that do not respond to the procedure above.

TO CLEAN THE OVEN/BROILER INTERIOR:

1. Allow the oven/broiler interior to cool, completely. Use a nonalkaline based cleaning agent, following the recommendations of the manufacturer. DO NOT use abrasives. Oven cleaner may be used on surfaces which have porcelain enameling.
2. Rinse thoroughly with cool, clean water. Dry thoroughly. Clean daily or as needed.
3. Should the pilot be extinguished, follow the Lighting Instructions.

To reduce down time and for maximum efficiency, have your appliance serviced once or twice a year, depending on the amount of usage. Have a technician:

- Examine the appliance venting system at least twice a year.
- Clean and adjust burners, lighters, regulators, and etc. twice a year.
- Check and calibrate the thermostats and the manifold pressure at least once a year.
- Regrease manual control valves. Call factory for service bulletin.

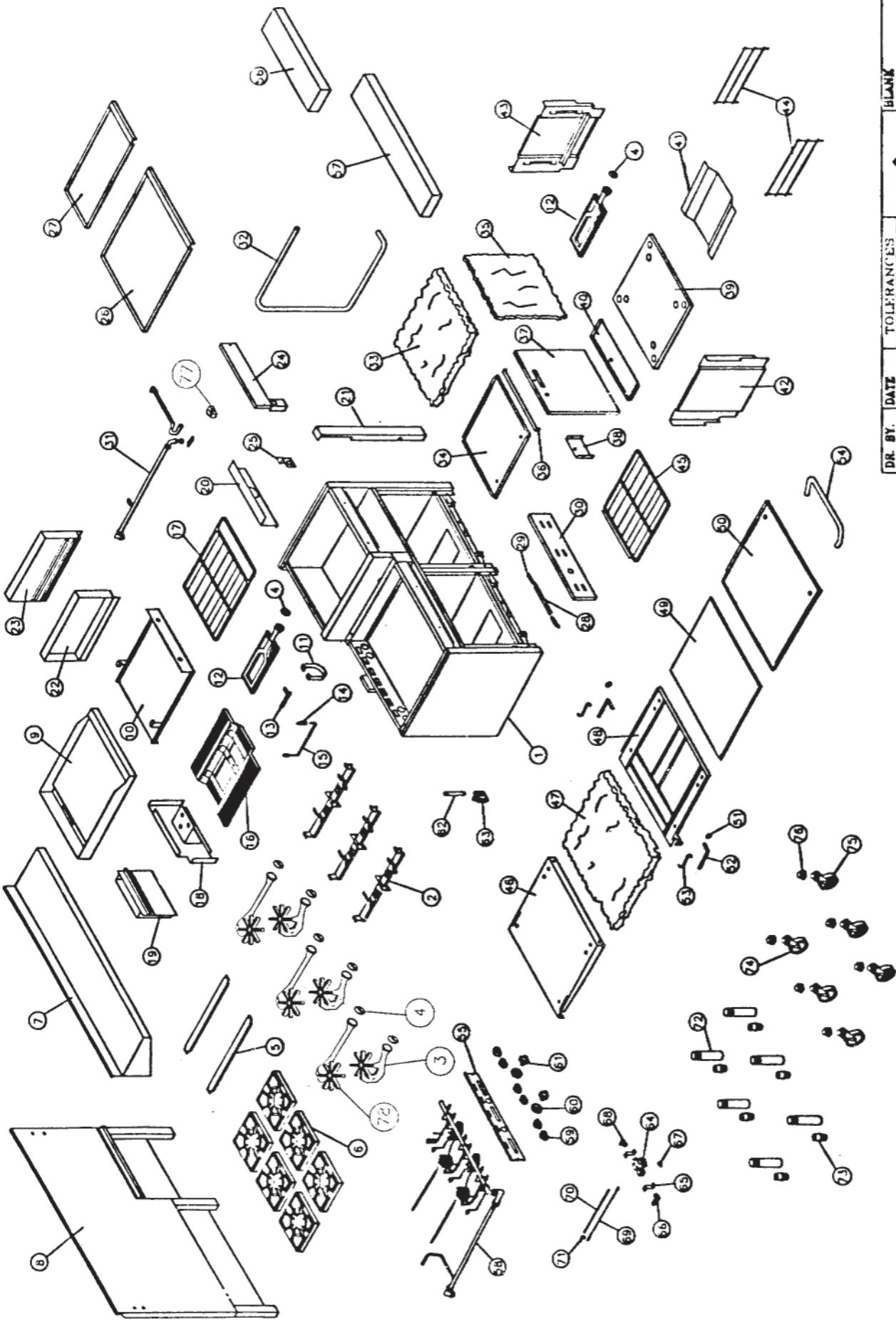

| | | | | |
|---------|-------|---|--|----------|
| DR. BY. | DATE | TOLERANCES UNLESS OTHERWISE NOTED |  COMSTOCK CASTLE STOVE CO. DEPARTMENT OF ENGINEERING 119 W WASHINGTON QUINCY ILL. 62301 | BLANK |
| MCD | 10/98 | ANGLES ± .3° XXX ± .030 XXXX ± .016 | | GAGE |
| CHK | DATE | | | MATL |
| APPR. | DATE | | | WEIGHT |
| SCALE | NTS | | TITLE | PART NO. |
| | | | F SERIES RANGE F3226B ASSY. | F3226B |

| | | | |
|------|----------|------------------|--------|
| 3/01 | B | CHGD. FOR MANUAL | MCD |
| DATE | REV. NO. | REVISIONS | CHK BY |

F3226-24B PARTS LIST

| ITEM # | PART # | DESCRIPTION | QTY. | ITEM # | PART # | DESCRIPTION | QTY. |
|--------|-----------|----------------------------------|------|--------|-------------|-----------------------------------|------|
| 1 | F3226-24B | F3226-24B BODY ASSY. | 1 | 44 | 21005 | RACK, OVEN SIDE LINING | 4 |
| 2 | FR84-A | ASSY., F SER. BURNER SUPPORT | 3 | 45 | 21020 | RACK, F3226 OVEN WIRE LOCKING | 2 |
| 3 | 16022 | BURNER , SHORT STAR | 3 | 46 | FZ31-AE | LINING, F3226 DOOR - ENAMELED | 2 |
| 4 | 16000 | MIXER, AIR - ROUND | 9 | 47 | 27010 | INSULATION, 16" x 32" x 2", F.G. | 2 |
| 5 | FR83 | RAIL, F SER. TOP GRATE SUPPORT | 2 | 48 | FZ32-A | ASSY., F3226 INNER DOOR | 2 |
| 6 | 16040 | GRATE, F SER. TOP - CAST IRON | 6 | 49 | 27043 | INSUL., 16" x 27" x 1/16", MILBD. | 2 |
| 7 | FZ69W | SHELF, F3226 | 1 | 50 | FZ30 | DOOR, F3226 MAIN | 2 |
| 8 | FZ70-A | ASSY., F3226B BACK SPLASHER | 1 | 51 | 13030 | WASHER, FIBER 1/4" | 4 |
| 9 | F24RD-PA | ASSY., 24" REAR DRAIN PLATE | 1 | 52 | FR32P | PIN, F SER. OVEN HINGE | 4 |
| 10 | FR28-24A | ASSY., 24" BROILER STEAK PAN | 1 | 53 | FR30H | HOOK, OVEN "S" DOOR | 4 |
| 11 | FR68-3 | CLAMP, BROILER FLAME SPREADER | 1 | 54 | 23017 | HANDLE, F3226 OVEN DOOR | 2 |
| 12 | 16013 | BURNER, "H" LARGE - CAST IRON | 3 | 55 | FY60 | APRON, F330 RANGE | 1 |
| 13 | FR128-A | ASSY., PLATE LIGHTER BRACKET | 1 | 56 | FR118-24BW | REST, 24" BROILER PLATE | 1 |
| 14 | 25015 | VALVE, 3/16" SING. ADJ. PILOT | 1 | 57 | FR118-36W | REST, F330 PLATE | 1 |
| 15 | 25050-15 | ASSY., 15" CHINA HAT | 1 | 58a | F3226-24B | ASSY., F3226-24B MANIFOLD - NAT. | 1 |
| 16 | FR68-A | ASSY., BROILER FLAME SPREADER | 1 | 58b | F3226-24B | ASSY., F3226-24B MANIFOLD - L.P. | 1 |
| 17 | 21026 | RACK, 24" BROILER | 1 | 59 | 18030 | KNOB, F SER. BIG MANUAL, ON-OFF | 6 |
| 18 | FR87-A | ASSY., BROILER BURNER SUPPORT | 1 | 60 | 18013 | BEZEL, BJWA THERMOSTAT | 2 |
| 19 | FR104-A | ASSY., F SER. GREASE CHUTE EXT. | 1 | 61 | 18012 | KNOB, BJWA THERMOSTAT | 2 |
| 20 | FRG67-24 | SHIELD, 24" BROILER VALVE | 1 | 62 | 25131 | NIPPLE, 3/4" x 5", BLACK | 2 |
| 21 | FR78F | STRIP, F3226B FRONT CENTER | 1 | 63a | 17006N | CONVERTIBLE REGULATOR - NAT. | 2 |
| 22 | FRB115-RA | ASSY., BROILER RIGHT SIDE LINING | 1 | 63b | 17006L | CONVERTIBLE REGULATOR - L.P. | 2 |
| 23 | FRB115-LA | ASSY., BROILER LEFT SIDE LINING | 1 | 64 | 17017/17018 | VALVE, OVEN SAFETY | 2 |
| 24 | FR60-B24 | ASSY., 24" BROILER APRON | 1 | 65 | FR159 | LEG, OVEN SAFETY VALVE | 4 |
| 25 | CG108 | SUPPORT, C.G. ORIFICE | 1 | 66 | 25220 | ELBOW, 3/8"NPT x 3/8"CC, BRASS | 2 |
| 26 | FY29SW | PAN, F330 DRIP | 1 | 67 | 25196 | BREAKAWAY, 3/16" | 2 |
| 27 | FX29W | PAN, F318 DRIP | 1 | 68 | 20110 | ELBOW, OVEN BURNER MIXER | 2 |
| 28 | FZ39 | COUPING, F3226 SPRING | 2 | 69 | 17005 | CONTROL, #T46 THERMOCOUPLE | 2 |
| 29 | 23008 | SPRING, OVEN DOOR | 4 | 70 | 26100-18 | TUBING, 3/16" x 18", ALUM. FEED | 2 |
| 30 | FZ61-A | ASSY., F3226 LOWER PANEL | 2 | 71a | 17002-A | ASSY., PILOT HEAD - NAT. | 2 |
| 31a | BROIL-M1 | ASSY., BROILER MANIFOLD - NAT. | 1 | 71b | 17003-A | ASSY., PILOT HEAD - L.P. | 2 |
| 31b | BROIL-M2 | ASSY., BROILER MANIFOLD - L.P. | 1 | 72 | 14045 | LEG, 6" RANGE PIPE - CHROME | 6 |
| 32 | 26149 | TUBE, 7/16" OVEN FEED | 2 | 73 | 14041 | FOOT, RANGE ADJUSTABLE | 6 |
| 33 | 27015 | INSULATION, 22" x 27" x 2", F.G. | 2 | 74 | 14051 | CASTER, NON-LOCKING | 3 |
| 34 | FZ112 | LINING, F3226 OVEN TOP | 2 | 75 | 14050 | CASTER, LOCKING | 3 |
| 35 | 27012 | INSULATION, 19" x 27" x 2", F.G. | 2 | 76 | 25174 | BUSHING, 3/4" x 1-1/4", HEX | 6 |
| 36 | FZ44B | SPACER, F3226 OVEN BOTTOM | 2 | 77 | 18005/18030 | KNOB, BLUE, ON-OFF, MANUAL | 1 |
| 37 | FZ114-A | ASSY., F3226 OVEN BACK LINING | 2 | 78 | 16021 | BURNER, LONG STAR | 3 |
| 38 | FR157 | HOLDER, OVEN THERMO. BULB | 2 | | | | |
| 39 | FZ111-AE | ASSY., F3226 OVEN BOTTOM LINING | 2 | | | | |
| 40 | FZ44B | SPACER, F3226 OVEN BOTTOM | 2 | | | | |
| 41 | FR64 | PLATE, F SER. BAFFLE | 2 | | | | |
| 42 | FR115-RA | ASSY., F SER. RIGHT SIDE LINING | 2 | | | | |
| 43 | FR115-LA | ASSY., F SER. LEFT SIDE LINING | 2 | | | | |

| PO31 UNIT ASSEMBLY | | | |
|--------------------|----------|---------------------------------------|------|
| ITEM # | PART # | DESCRIPTION | QTY. |
| 1 | PO31-BA | PO31 BODY ASSEMBLY | 1 |
| 2 | 27013 | INSULATION, 19" x 33" x 3", F.G. | 1 |
| 3 | FY114-A | F SER. 330 OVEN BACK LINING ASSY. | 1 |
| 4 | 27016 | INSULATION, 22" x 33" x 2", F.G. | 1 |
| 5 | FY112 | F SER. 330 OVEN TOP LINING | 1 |
| 6 | FR115R-A | F SER. SIDE LINING ASSY. -- RIGHT | 1 |
| 7 | FR115L-A | F SER. SIDE LINING ASSY. -- LEFT | 1 |
| 8 | 21005 | OVEN SIDE RACKS | 2 |
| 9 | FPY67 | PO31 VALVE COVER | 1 |
| 10 | FY44B | F SER. 330 OVEN BOTTOM SPACER | 2 |
| 11 | FP130 | F SER. PIZZA BACK-OUT PIPE BRACKET | 1 |
| 12 | PO31-M1 | PO31 MANIFOLD ASSY. | 1 |
| 13a | FP904-41 | F SER. PIZZA 4" TUBING ASSY. -- NAT. | 1 |
| 13b | FP904-52 | F SER. PIZZA 4" TUBING ASSY. -- L.P. | 1 |
| 14 | 16000 | MIXER, AIR -- ROUND | 1 |
| 15 | 16013 | BURNER, CAST IRON "H" LARGE | 1 |
| 16a | 17002-A | PILOT HEAD CONTROL ASSY. -- NAT. | 1 |
| 16b | 17003-A | PILOT HEAD CONTROL ASSY. -- L.P. | 1 |
| 17 | 23018 | HANDLE, F330 OVEN DOOR -- 1-1/4" DIA. | 1 |
| 18a | 17006N | CONTROL, NATURAL GAS REGULATOR | 1 |
| 18b | 17006L | CONTROL, PROPANE GAS REGULATOR | 1 |
| 19 | FR157 | F SER. OVEN THERMO. BULB BRACKET | 1 |
| 20 | FY31 | F SER. 330 DOOR LINING | 1 |
| 21 | 27044 | INSULATION, 16" x 32" x 1/8", SHEET | 1 |
| 22 | FY32-A | F SER. 330 INNER DOOR ASSY. | 1 |
| 23 | 27010 | INSULATION, 16" x 32" x 2", F.G. | 1 |
| 24 | FY30 | F SER. 330 MAIN DOOR | 1 |
| 25 | FR30H | HOOK, OVEN DOOR | 2 |
| 26 | FY111-A | F SER. 330 BOTTOM LINING ASSY. | 1 |
| 27 | FR64 | F SER. OVEN BAFFLE PLATE | 1 |
| 28 | FR32P | OVEN HINGE PIN | 2 |
| 29 | 13030 | WASHER, 1/4" BLACK FIBER | 2 |
| 30 | 23008 | SPRING, OVEN DOOR -- #42 | 2 |
| 31 | FPY60 | PO31 CONTROL PANEL | 1 |
| 32 | 21032 | PO31 TRANSITE | 2 |
| 33 | 18030 | KNOB, F SER. BIG MANUAL, ON-OFF | 1 |

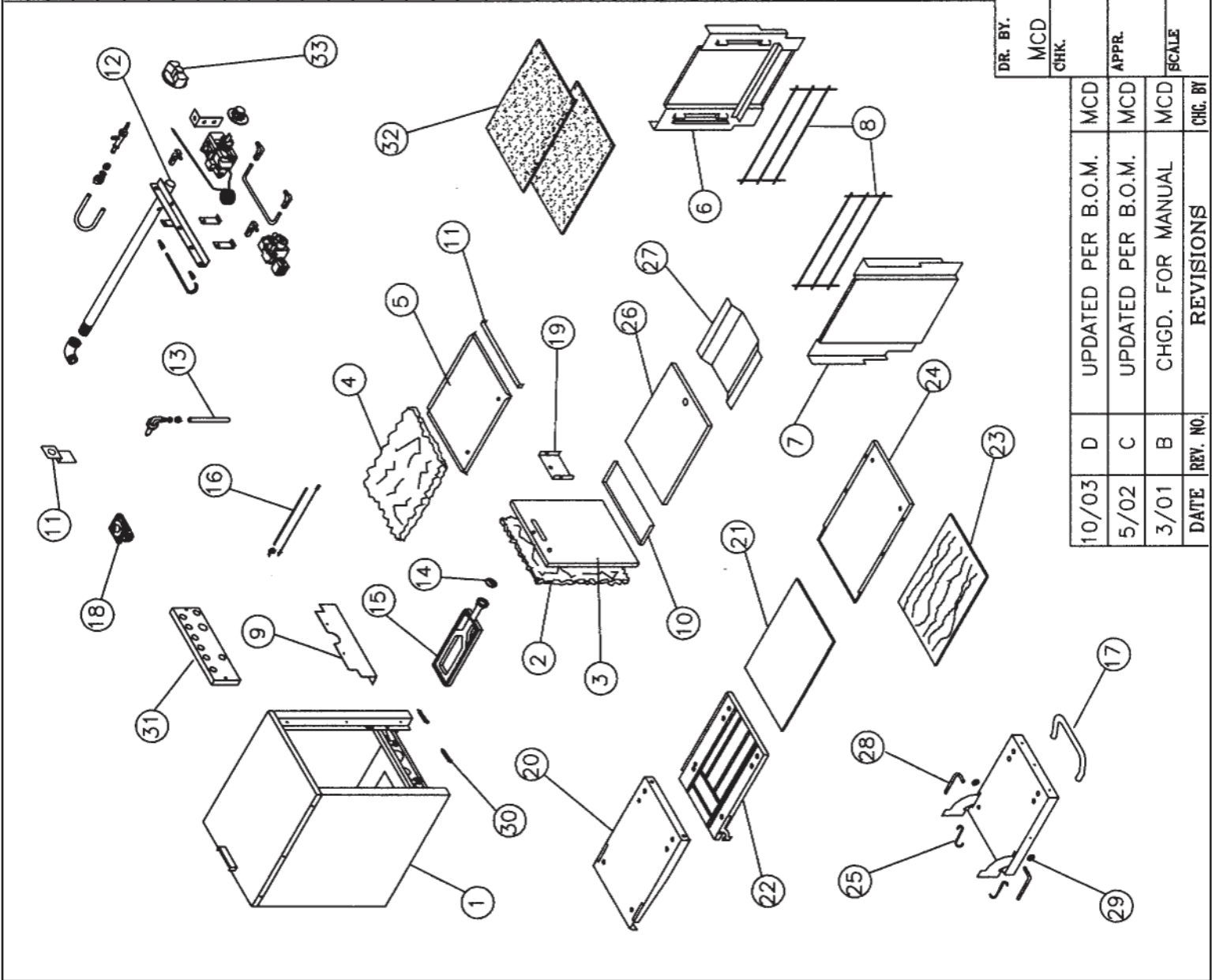

| | |
|---------|------|
| DR. BY. | DATE |
| MCD | 9/98 |
| CHK. | DATE |
| APPR. | DATE |
| SCALE | DATE |

| | | | |
|-------|----------|--------------------|---------|
| 10/03 | D | UPDATED PER B.O.M. | MCD |
| 5/02 | C | UPDATED PER B.O.M. | MCD |
| 3/01 | B | CHGD. FOR MANUAL | MCD |
| DATE | REV. NO. | REVISIONS | CHG. BY |

BLANK

GAGE

QTY.

MATL.

WEIGHT

PART NO.

PO31 UNIT ASSEMBLY

PO31

COMSTOCK CASTLE STOVE CO.
DEPARTMENT OF ENGINEERING
119 W. WASHINGTON QUINCY, ILL. 62306

TITLE

NTS

| ITEM NO. | PART NO. | DESCRIPTION | QTY |
|----------|------------|------------------------------------|-----|
| 1 | FHP36-BA | ASSY., FHP36 BODY | 1 |
| 2 | F36-84 | SUPPORT, FHP 36" BURNER | 1 |
| 3 | 14044-A | LEG, 4" COUNTER W/ ADJ. FOOT | 4 |
| 4 | FHP29C-A | ASSY., FHP DRIPPAN CHANNEL | 2 |
| 5a | F36B-M1 | ASSY., FHP36 BROILER MANIFOLD-NAT. | 1 |
| 5b | F36B-M2 | ASSY., FHP36 BROILER MANIFOLD-L.P. | 1 |
| 6 | 26025-FA | ASSY., FHP SER. 25" BACK-OUT | 1 |
| 7 | 16000 | MIXER, AIR- ROUND | 3 |
| 8 | 16013 | BURNER, "H" LARGE - CAST IRON | 3 |
| 9 | FR128-A | ASSY., GRIDDLE LIGHTER BRACKET | 3 |
| 10 | F36-29 | DRIPPAN, FHP 36" | 1 |
| 11 | FHP104-A | ASSY., FHP GREASE CHUTE | 1 |
| 12 | F36-195A | ASSY., FHP 36" RADIANT FIREBOX | 1 |
| 13 | 30003-A | ASSY., FHP LARGE TP BROILER ANGLE | 5 |
| 14 | 30001-17.5 | ANGLE, FHP SMALL TP BROILER | 6 |
| 15 | FR118-36 | REST, F SERIES 36" PLATE | 1 |
| 16 | FR118B | BRACKET, F SER. PLATE REST | 3 |
| 17 | F36-60 | APRON, FHP 36" | 1 |
| 18 | 18030 | KNOB, F SER. BIG MANUAL, ON-OFF | 3 |
| 19 | F36-167A | ASSY., FHP 36" BROILER WRAP | 1 |
| 20 | 16041 | GRATE, F SER. RADIANT BROILER TOP | 6 |

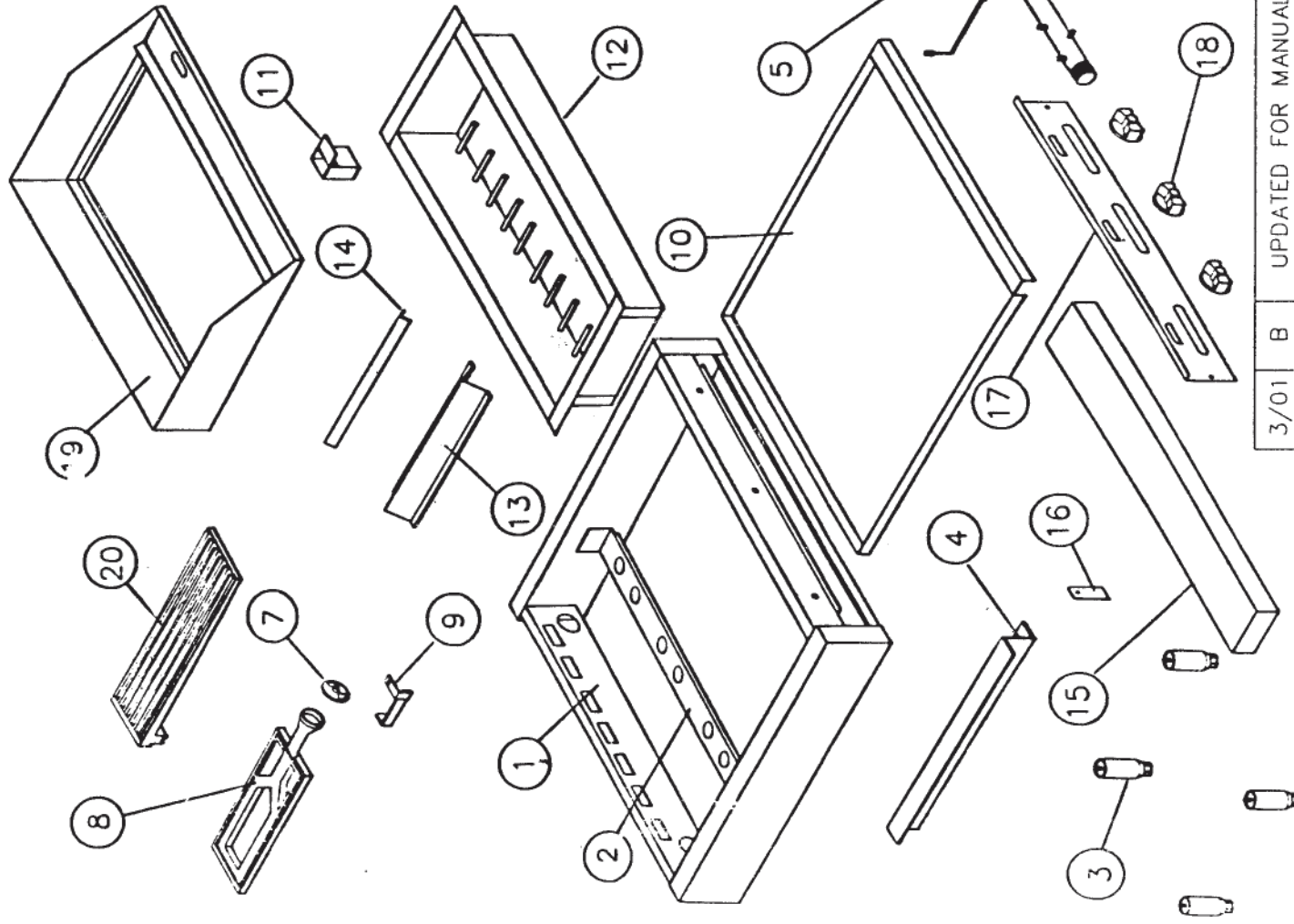

| | | |
|----------|------|------------------------------------|
| DR. BY. | DATE | BLANK |
| MCD | 8/98 | |
| CHK. | DATE | GAUGE |
| APPR. | DATE | QTY |
| SCALE | DATE | MATL. |
| MCD | DATE | WEIGHT |
| CHK. BY. | DATE | PART NO. |
| | | FHP36-3RB |
| | | RADIANT BROILER |
| | | TITLE |
| | | FHP36-3RB |
| | | 119 W. WASHINGTON QUINCY, IL 62301 |
| | | DEPARTMENT OF ENGINEERING |
| | | COMSTOCK CASTLE STOVE CO. |

| | | | |
|------|---------|--------------------|----------|
| 3/01 | B | UPDATED FOR MANUAL | MCD |
| DATE | REV NO. | REVISIONS | CHK. BY. |

| ITEM NO. | PART NO. | DESCRIPTION | QTY. |
|----------|----------|---------------------------------|------|
| 1 | FHP36-BA | ASSY., FHP36 BODY | 1 |
| 2a | F36G-M1 | ASSY., FHP36-36 MANIFOLD - NAT. | 1 |
| 2b | F36G-M2 | ASSY., FHP36-36 MANIFOLD - L.P. | 1 |
| 3 | 26025-FA | ASSY., FHP SER. 25" BACK-OUT | 1 |
| 4 | FHP104-A | ASSY., FHP GREASE CHUTE | 1 |
| 5 | FR128-A | ASSY., GRIDDLE LIGHTER BRACKET | 3 |
| 6 | 16013 | BURNER, "H" LARGE - CAST IRON | 3 |
| 7 | V101 | DRAWER, 10 SERIES GREASE | 1 |
| 8 | F36-60 | APRON, FHP 36" | 1 |
| 9 | FR118-36 | REST, F SERIES 36" PLATE | 1 |
| 10 | F36-67 | SHIELD, FHP 36" BURNER | 1 |
| 11 | F36-84 | SUPPORT, FHP 36" BURNER | 1 |
| 12 | 16000 | MIXER, AIR - ROUND | 3 |
| 13 | F36-PA | ASSY., F SER. 36" GRIDDLE PLATE | 1 |
| 14 | FHP102 | SLIDE, FHP GREASE DRAWER | 1 |
| 15 | 14044-A | LEG, 4" COUNTER W/ ADJ. FOOT | 4 |
| 16 | 18030 | KNOB, F SER. BIG MANUAL, ON-OFF | 3 |
| 17 | 17039 | CONTROL, F SER. T-STAT GRIDDLE | 1 |

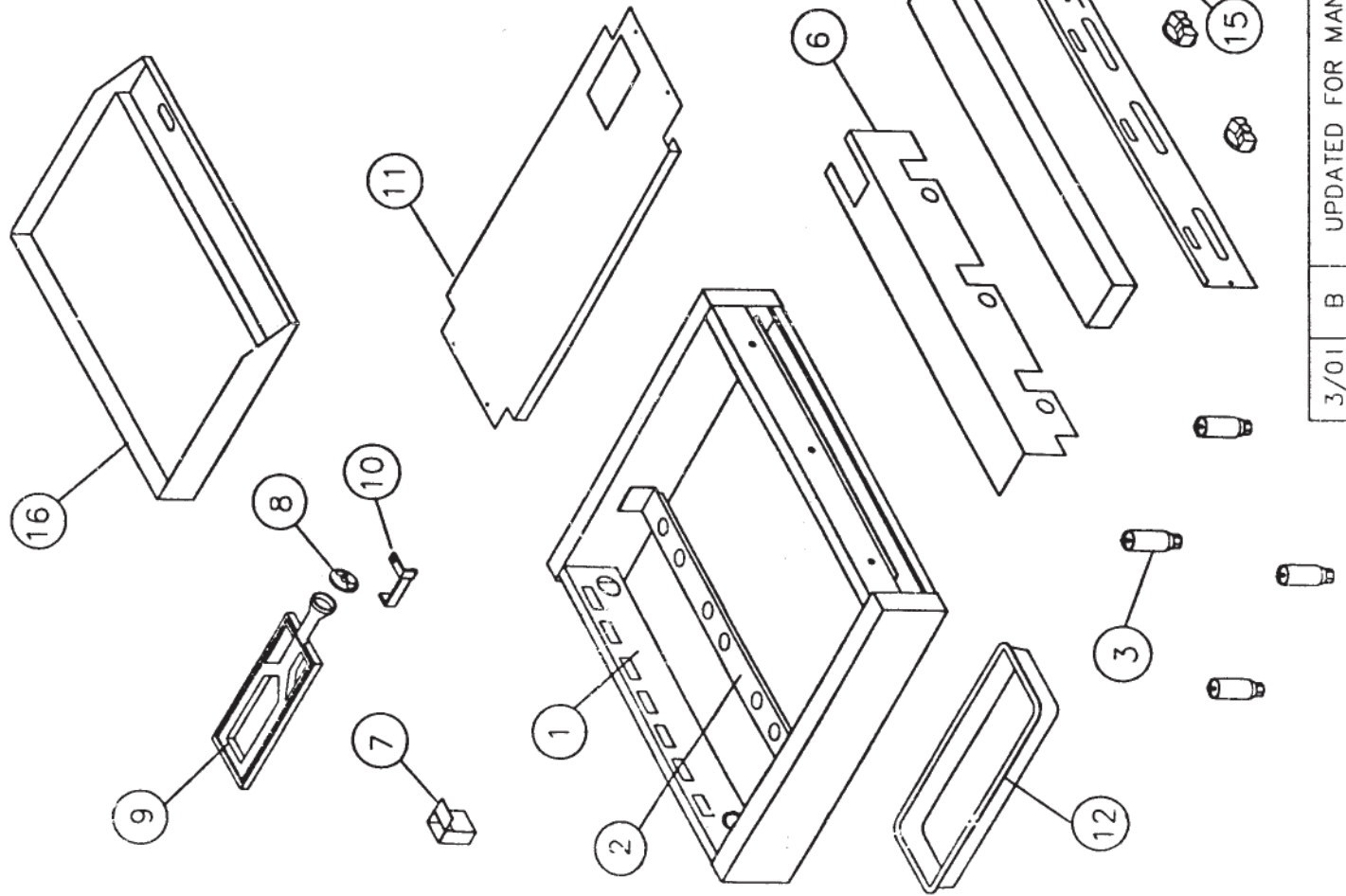

| | | |
|------------------|------|----------|
| DR. BY. | DATE | BLANK |
| MCD | 8/98 | GAGE |
| CHK. | DATE | QTY. |
| APPR. | DATE | MATL. |
| SCALE | DATE | WEIGHT |
| TITLE | | PART NO. |
| FHP36-36 GRIDDLE | | FHP36-36 |



 COMSTOCK CASTLE STOVE CO.
 DEPARTMENT OF ENGINEERING
 119 W. WASHINGTON QUINCY, IL 62301

| | | | |
|------|----------|--------------------|---------|
| 3/01 | B | UPDATED FOR MANUAL | MCD |
| DATE | REV. NO. | REVISIONS | CHK. BY |

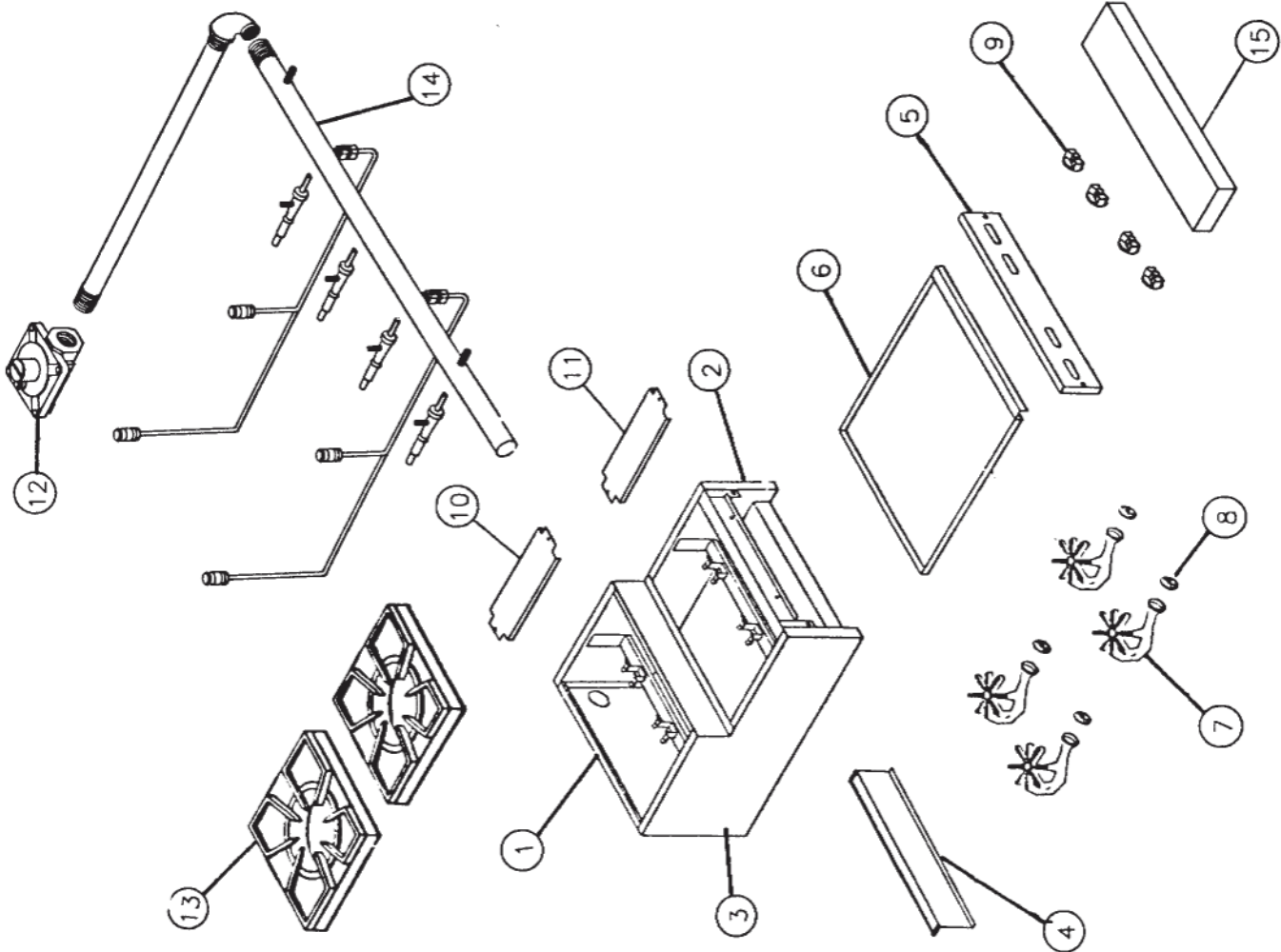
| ITEM NO. | PART NO. | DESCRIPTION | QTY. |
|----------|-----------|-------------------------------------|------|
| 1 | FST24-BA | ASSY., STFHP24 BODY | 1 |
| 2 | FST50L | SIDE, STFHP MAIN - LEFT | 1 |
| 3 | FST50R | SIDE, STFHP MAIN - RIGHT | 1 |
| 4 | FST60-24U | APRON, STFHP24 UPPER | 1 |
| 5 | FST60-24L | APRON, STFHP24 LOWER | 1 |
| 6 | FY29SW | DRIP PAN, F330 | 1 |
| 7 | 16022 | BURNER, SHORT STAR | 4 |
| 8 | 16000 | MIXER, AIR - ROUND | 4 |
| 9 | 18030 | KNOB, F SER. BIG MANUAL, ON-OFF | 4 |
| 10 | FST83B | RAIL, STFHP TOP GRATE SUPPORT-BACK | 1 |
| 11 | FST83F | RAIL, STFHP TOP GRATE SUPPORT-FRONT | 1 |
| 12a | 17006N | REGULATOR, NATURAL | 1 |
| 12b | 17006L | REGULATOR, PROPANE | 1 |
| 13 | 16040 | GRATE, F SER. TOP - CAST IRON | 4 |
| 14a | FST24-M1 | ASSY., STFHP24 MANIFOLD - NAT. | 1 |
| 14b | FST24-M2 | ASSY., STFHP24 MANIFOLD - L.P. | 1 |
| 15 | FR118-24W | REST, F RANGE 24" PLATE | 1 |

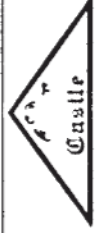

| | | |
|---------|-----------|----------|
| DR. BY. | DATE | BLANK |
| MCD | 5/02 | GAGE |
| CHK. | DATE | QTY. |
| APPR. | DATE | MATL. |
| SCALE | NTS | WEIGHT |
| CHG. BY | REVISIONS | PART NO. |
| | | STFHP24 |

CONSTOCK CASTLE STOVE CO.
DEPARTMENT OF ENGINEERING
 119 W. WASHINGTON QUINCY, IL 62301
 TITLE: SUFHP ASSEMBLY

| ITEM NO. | PART NO. | DESCRIPTION | QTY. |
|----------|----------|-------------------------------------|------|
| 1 | 1030-BA | 1030 BODY ASSY. | 1 |
| 2 | V104A | 10 SER. GREASE CHUTE ASSY. | 1 |
| 3 | V101 | 10 SER. GREASE DRAWER | 1 |
| 4 | V60-30 | 1030 APRON | 1 |
| 5a | 1030-M1 | 1030 MANIFOLD ASSY. - NAT. | 1 |
| 5b | 1030-M2 | 1030 MANIFOLD ASSY. - L.P. | 1 |
| 6a | 17006N | REGULATOR, CONVERTIBLE - NAT. | 1 |
| 6b | 17006L | REGULATOR, CONVERTIBLE - L.P. | 1 |
| 7 | 18030 | KNOB, MANUAL, ON-OFF, F SER. - BLUE | 3 |
| 8 | V128L | 10 SER. LIGHTER BRACKET - LEFT | 2 |
| 9 | V128R | 10 SER. LIGHTER BRACKET - RIGHT | 1 |
| 10 | 16001 | MIXER, AIR - TRIANGLE | 3 |
| 11 | 16014 | BURNER, SMALL "H" CAST IRON | 3 |
| 12 | 11018 | BOLT, #10-24 x 3/8" | 3 |
| 13 | 1030-PA | 1030 PLATE ASSY. | 1 |
| 14 | 17033 | CONTROL, GS THERMOSTAT | 1 |

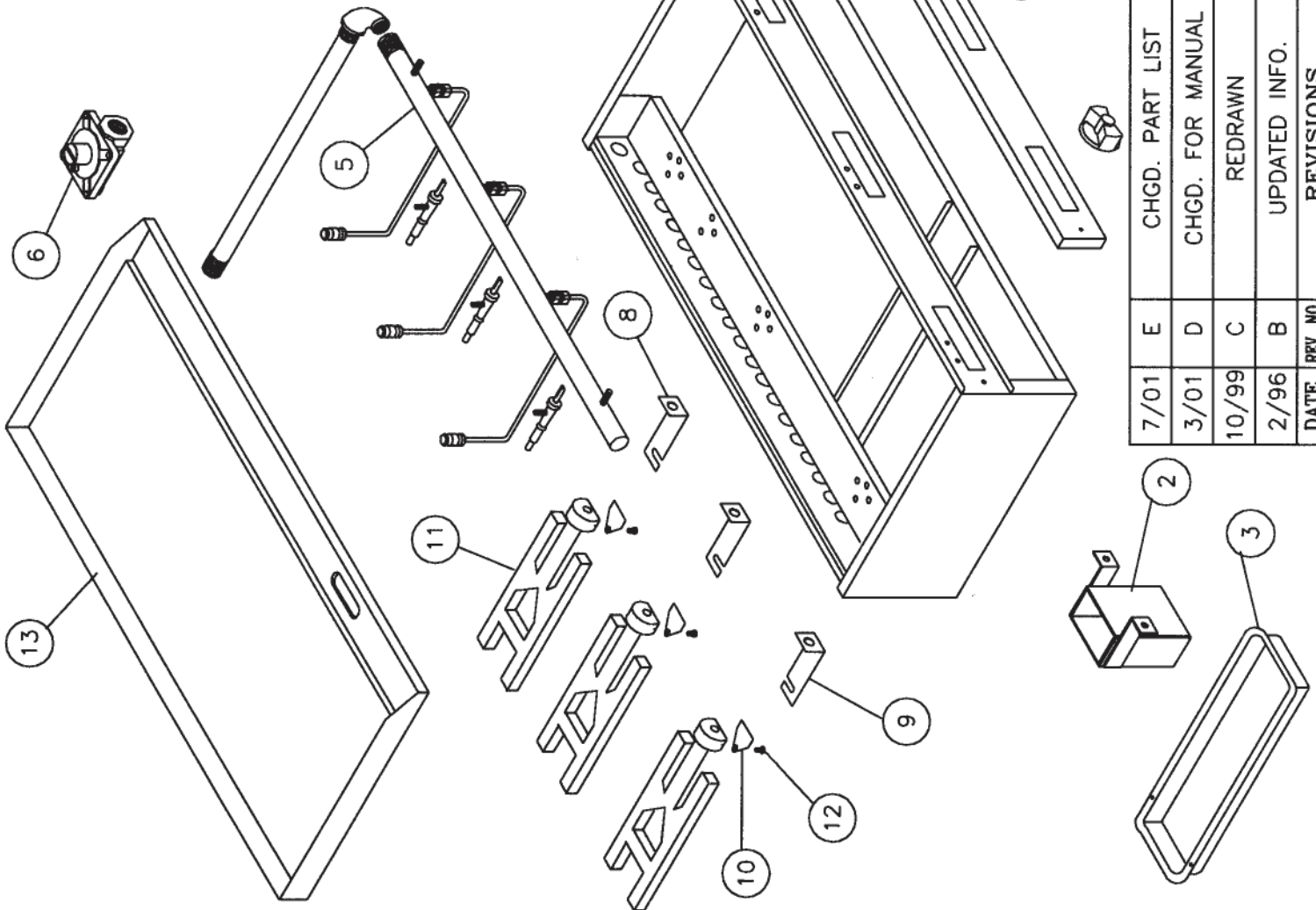

| DATE | REV. NO. | REVISIONS | CHK. BY |
|-------|----------|------------------|---------|
| 7/01 | E | CHGD. PART LIST | MCD |
| 3/01 | D | CHGD. FOR MANUAL | MCD |
| 10/99 | C | REDRAWN | MCD |
| 2/96 | B | UPDATED INFO. | MCD |

| DR. BY. | DATE | SCALE | TITLE |
|-----------|------|-------|--------------------|
| R.H. CHK. | 2/91 | NTS | 1030 UNIT ASSEMBLY |

| BLANK | GAGE | QTY. |
|-------|------|------|
| | | |

COMSTOCK CASTLE STOVE CO.
 DEPARTMENT OF ENGINEERING
 119 W. WASHINGTON QUINCY, IL 62301

PART NO. 1030

| ITEM NO. | PART NO. | DESCRIPTION | QTY. |
|----------|----------|-----------------------------------|------|
| 1 | CSP18-BA | CSP18 BODY ASSEMBLY | 1 |
| 2 | 14046 | CSP LEG w/ FOOT | 4 |
| 3 | CSP29SW | CSP18 DRIP PAN | 1 |
| 4 | 16069-A | CSP/SP INNER RING BURNER ASSY. | 1 |
| 5 | 16070-A | CSP OUTER RING BURNER ASSY. | 1 |
| 6a | CSP18-M1 | CSP18 MANIFOLD ASSY. - NAT. | 1 |
| 6b | CSP18-M2 | CSP18 MANIFOLD ASSY. - L.P. | 1 |
| 7a | 17006N | CONVERTIBLE REGULATOR - NAT. | 1 |
| 7b | 17006L | CONVERTIBLE REGULATOR - L.P. | 1 |
| 8 | CSP61-18 | CSP18 APRON - GENERIC | 1 |
| 9 | 18030 | KNOB, MAN., ON-OFF, F SER. - BLUE | 2 |
| 10 | 16031 | GRATE, CSP TOP - GENERIC | 1 |

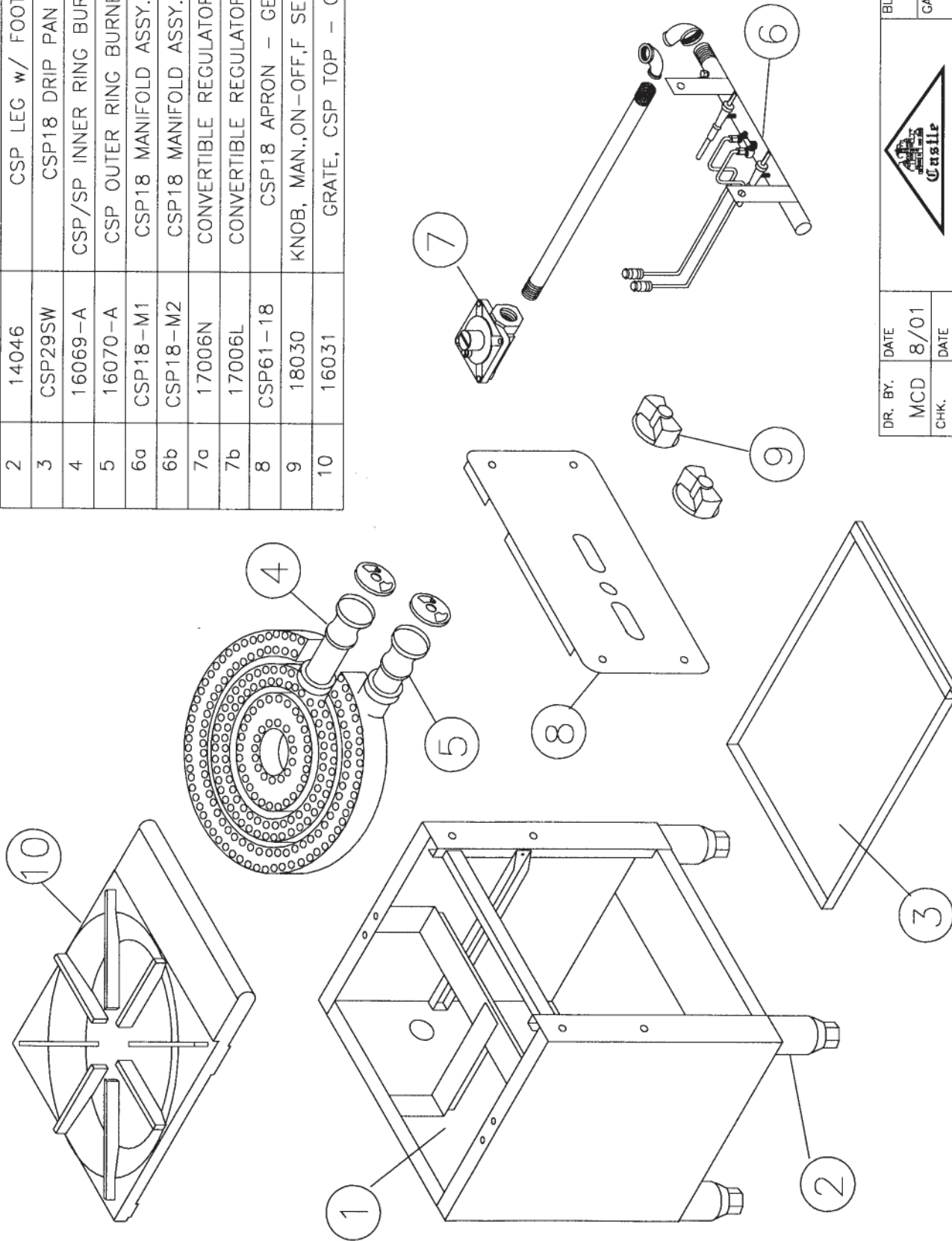

| | | |
|----------|-----------|----------|
| DR. BY. | DATE | BLANK |
| MCD | 8/01 | GAGE |
| CHK. | DATE | QTY. |
| APPR. | DATE | MATL. |
| SCALE | NTS | WEIG. |
| REV. NO. | REVISIONS | PART NO. |
| | | CSP18 |



CONSTOCK CASTLE STOVE CO.
 DEPARTMENT OF ENGINEERING
 119 W. WASHINGTON QUINCY, IL 62301

TITLE: CSP18 UNIT ASSY.

| ITEM # | PART # | DESCRIPTION | QTY. |
|--------|----------|-----------------------------|------|
| 1 | FHP1-BA | ASSY., FHP1 BODY | 1 |
| 2 | FHP60-1 | FHP1 APRON | 1 |
| 3a | FHP1-M1 | ASSY., FHP1 MANIFOLD - NAT. | 1 |
| 3b | FHP1-M2 | ASSY., FHP1 MANIFOLD - L.P. | 1 |
| 4a | 17006N | REGULATOR - NATURAL | 1 |
| 4b | 17006L | REGULATOR - L.P. | 1 |
| 5 | 16026 | BURNER, SHORT STAR | 1 |
| 6 | 16000 | MIXER, AIR - ROUND | 1 |
| 7 | FHP118-1 | FHP1 BULLNOSE | 1 |
| 8 | 18030 | KNOB, F SER. BIG MANUAL | 1 |
| 9 | 16040 | GRATE, F SER. TOP | 1 |

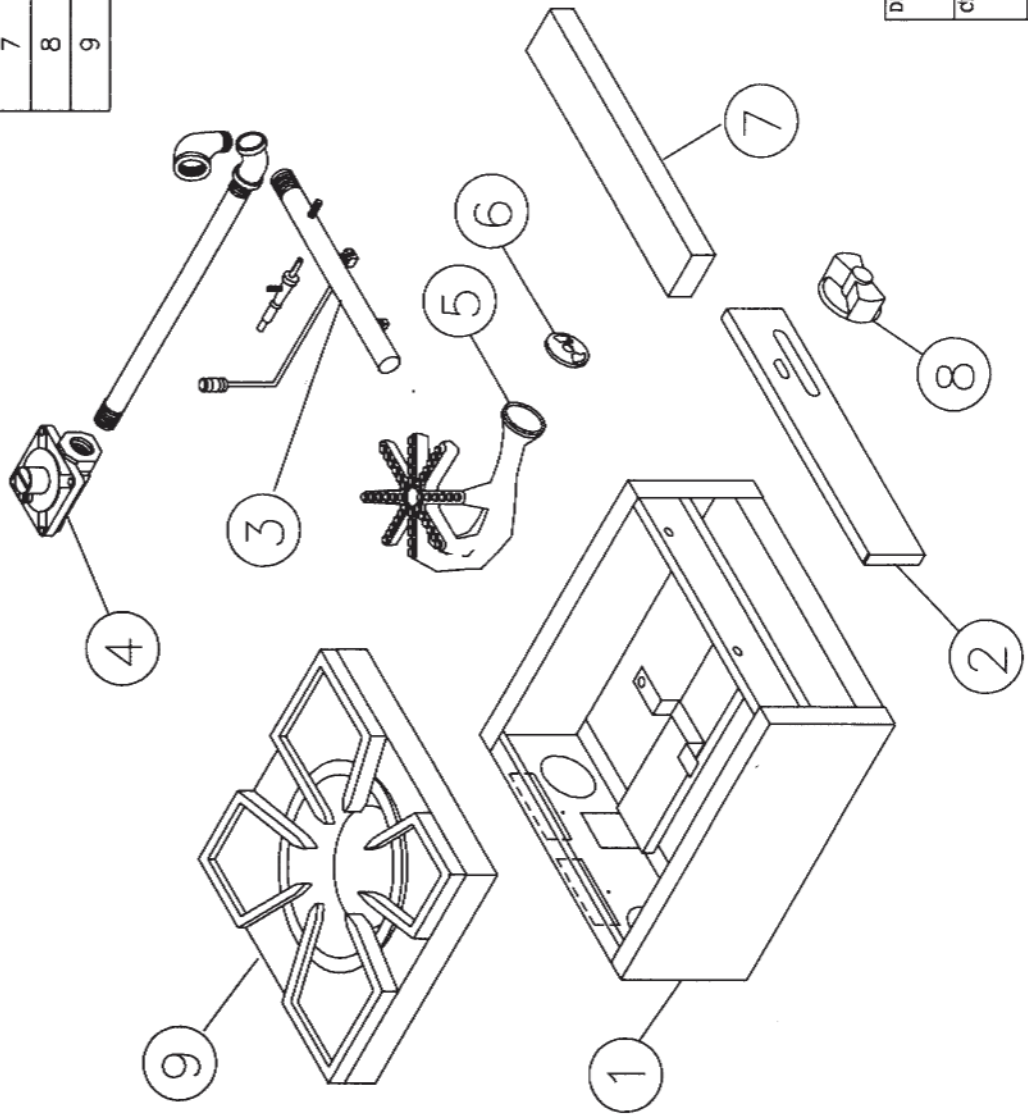

| | | |
|--------------------|------|----------|
| DR. BY. | DATE | BLANK |
| MCD | 3/01 | GAGE |
| CHK. | DATE | QTY. |
| APPR. | DATE | MATL. |
| SCALE | NTS | WEIGHT |
| TITLE | | PART NO. |
| FHP1 UNIT ASSEMBLY | | FHP1 |

CASTILE
 CONSTOCK CASTLE STOVE CO.
 DEPARTMENT OF ENGINEERING
 119 W. WASHINGTON QUINCY, IL 62301

| | | | |
|------|----------|--------------------|---------|
| 5/02 | B | CHGD. PART NUMBERS | MCD |
| DATE | REV. NO. | REVISIONS | CHK. BY |

| ITEM # | PART # | DESCRIPTION | QTY. |
|--------|----------|---------------------------------------|------|
| 1 | 2616-BA | ASSY., 2616 BODY | 1 |
| 2 | M67B-A | ASSY., 2616 BOTTOM HEAT SHIELD | 1 |
| 3a | 2616-M1 | ASSY., 2616 MANIFOLD - NAT. | 1 |
| 3b | 2616-M2 | ASSY., 2616 MANIFOLD - L.P. | 1 |
| 4 | 16013 | BURNER, "H" LARGE - CAST IRON | 2 |
| 5 | 27053 | INSULATION, 13-5/8" x 10-1/4", MILBD. | 1 |
| 6 | M67F | SHIELD, 2616 FRONT HEAT | 1 |
| 7 | M97-A | ASSY., 2616 MAIN POT | 1 |
| 8 | 21050-16 | SUPPORT, 2616 ALUM. BAR | 2 |
| 9 | 21051 | SPACER, 1/2" x 3/4" RD. ALUM. | 4 |
| 10 | 14034 | VALVE, 3/4" DRAIN | 1 |
| 11 | M31-A | ASSY., 2616 DOOR LINING | 1 |
| 12 | 23027 | MAGNET, FRYER DOOR #555 | 1 |
| 13 | 23036-A | ASSY., FRYER DOOR HINGE | 2 |
| 14 | M30 | DOOR, 2616 MAIN | 1 |
| 15 | 23030 | HANDLE, FRYER DOOR - CAST ALUM. | 1 |
| 16 | 14044-A | LEG, 4" COUNTER W/ ADJ. FOOT | 4 |
| 17 | M55E | EXTENTION, 2616 FLUE | 1 |
| 18 | 21081 | BASKET, 2616 | 2 |
| 19 | M120-A | ASSY., 2616 CRUMB TRAY | 1 |

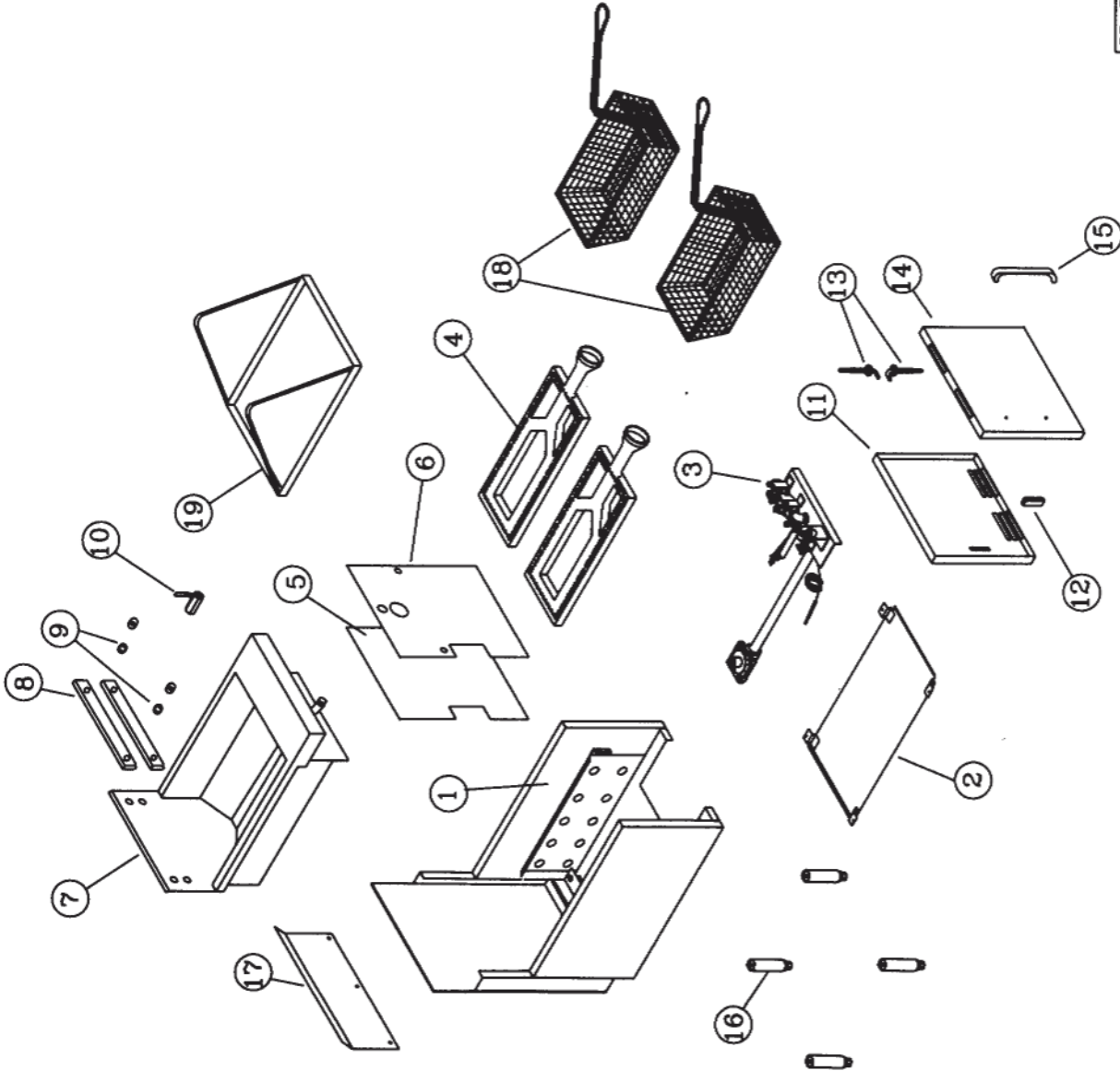
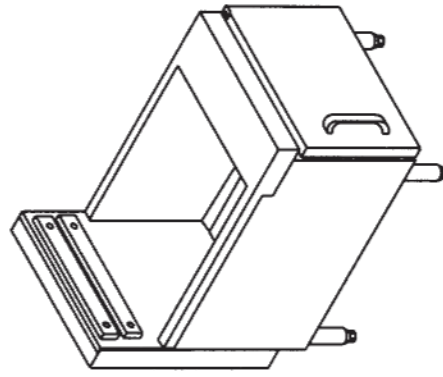

| | | |
|--|----------|------------------------|
| DR. BY. | DATE | BLANK |
| M.D. | 1/92 | GAGE |
| CHK. | DATE | MATL. |
| APPR. | DATE | WEIGHT |
| SCALE | NTS | PART NO. |
| | | 2616 |
| COMSTOCK CASTLE STOVE CO. DEPARTMENT OF ENGINEERING 119 W. WASHINGTON QUINCY, IL 62301 | | TITLE |
| 3/01 C UPDATED FOR MANUAL MCD 9/97 B REDRAWN & UPDATED MCD | | 2616 UNIT ASSEMBLY |
| DATE | REV. NO. | REVISIONS |
| 3/01 | C | UPDATED FOR MANUAL MCD |
| 9/97 | B | REDRAWN & UPDATED MCD |
| DATE | REV. NO. | REVISIONS |
| | | |

| ITEM NO. | PART NO. | DESCRIPTION | QTY. |
|----------|----------|------------------------------------|------|
| 1a | 18HF-BA | 18HF MAIN BODY ASSY. | 1 |
| 1b | 18HFC-BA | 18HF MAIN BODY ASSY. W/ COUPLING | 1 |
| 2 | 14049-A | LEG, 6" TUBE FRYER W/ ADJ. FOOT | 4 |
| 3 | 8HF68-A | 18HF FLAME SPREADER ASSY. | 4 |
| 4 | 8HF157-A | 18HF MAIN POT ASSY. | 1 |
| 5 | 8HF400-A | 18HF FLUE ASSY. | 1 |
| 6 | 8HF70-A | 18HF BACK SPLASHER ASSY. | 1 |
| 7 | 8HF55B | 18HF FALSE FLUE BACK | 1 |
| 8 | 21051 | SPACER, 1/2" LG. x 3/4" RD., ALUM. | 4 |
| 9 | 21050-19 | SUPPORT, 18HF BASKET, ALUM. BAR. | 2 |
| 10 | 16012-A | ASSY., #T-28 PADDLE BURNER | 4 |
| 11 | 18HFLB-A | 18HF LIGHTER BAR ASSY. | 1 |
| 12a | 18HFP-40 | 18HF PIPE ASSY. - NAT. | 1 |
| 12b | 18HFP-54 | 18HF PIPE ASSY. - L.P. | 1 |
| 13a | 18HF-M1 | 18HF MANIFOLD ASSY. - NAT. | 1 |
| 13b | 18HF-M2 | 18HF MANIFOLD ASSY. - L.P. | 1 |
| 14 | 14033 | VALVE, 1" DRAIN | 1 |
| 15 | 23026 | MAGNET, DOOR #SP41 | 1 |
| 16 | HF40-A | HF DOOR HINGE ASSY. | 2 |
| 17 | 23030 | HANDLE, FRYER DOOR | 1 |
| 18 | 8HF30 | 18HF MAIN DOOR | 1 |
| 19 | 8HF31 | 18HF DOOR LINING | 1 |
| 20 | 21072 | 18HF BASKET LEVELER | 1 |
| 21 | 21082 | 18HF BASKET | 2 |
| 22 | 14050 | CASTER, LOCKING | 2 |
| 23 | 14051 | CASTER, NON-LOCKING | 2 |

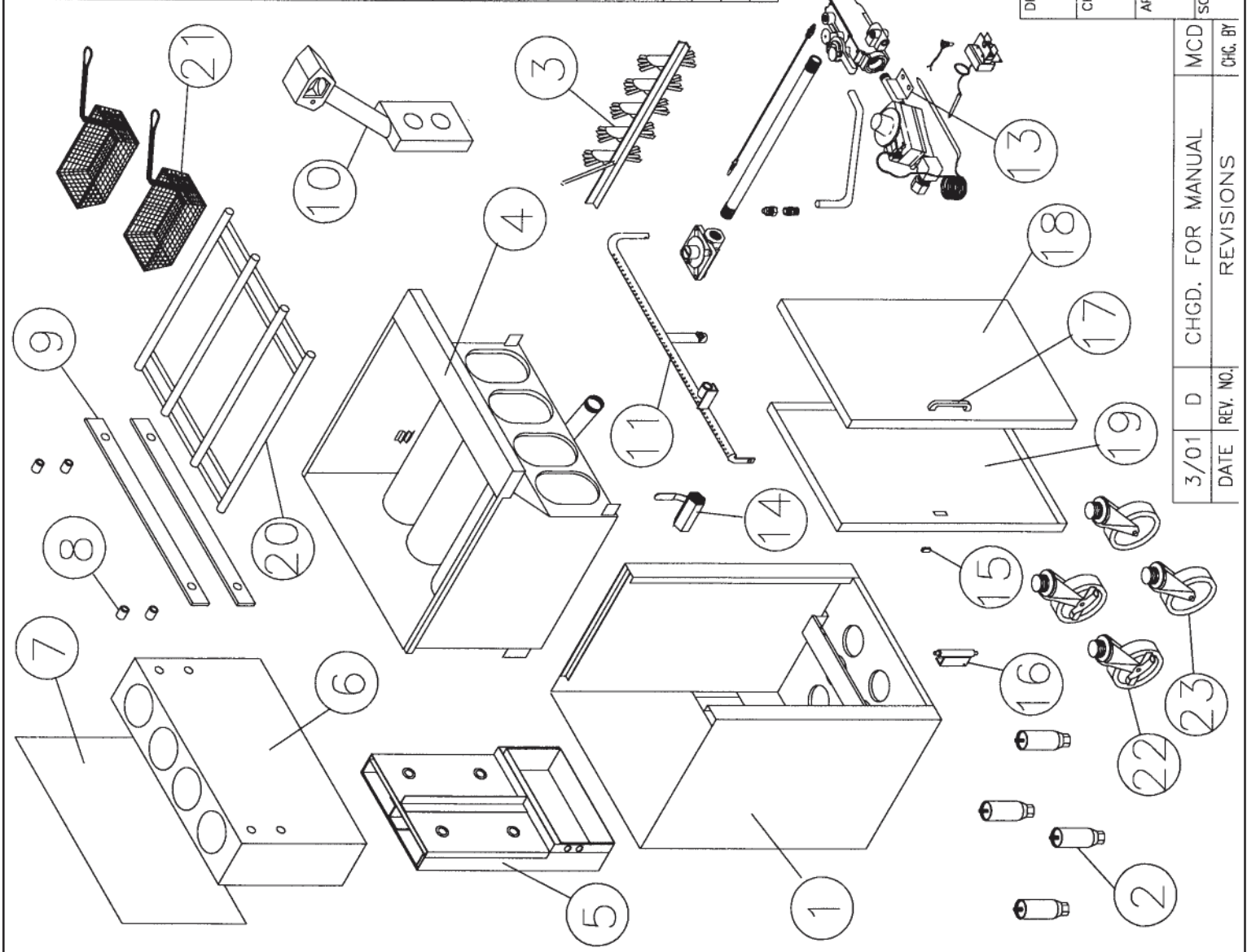

| | | |
|---------|-----------------|----------|
| DR. BY. | DATE | BLANK |
| M.D. | 11/91 | CAGE |
| CHK. | DATE | QTY. |
| APPR. | DATE | MATL. |
| SCALE | NTS | WEIGHT |
| MCD | TITLE | PART NO. |
| CHG. BY | 18HF UNIT ASSY. | 18HF |



COMSTOCK CASTILE STOVE CO.
 DEPARTMENT OF ENGINEERING
 119 W. WASHINGTON QUINCY, IL 62301

| ITEM NO. | PART NO. | DESCRIPTION | QTY. |
|----------|----------|-----------------------------------|------|
| 1 | 2932-BA | 2932FC BODY ASSEMBLY | 1 |
| 2 | 27030 | INSULATION, 27-3/8 x 11-3/8, F.G. | 2 |
| 3 | SF50 | 2932FC MAIN SIDE | 2 |
| 4 | 14020 | CLIP, APRON - FEMALE | 2 |
| 5 | 16013 | BURNER, "H" LARGE - CAST IRON | 3 |
| 6 | 16000 | MIXER, AIR - ROUND | 3 |
| 7 | SF67F | 2932FC HEAT SHIELD - FRONT | 1 |
| 8 | SF99-A | 2932FC MAIN POT ASSEMBLY | 1 |
| 9 | 14033 | VALVE, 1" DRAIN | 1 |
| 10 | SF3060-A | 2932FC APRON DOOR ASSY. | 1 |
| 11 | 23030 | HANDLE, FRYER DOOR | 1 |
| 12 | 14044-A | LEG, 4" W/ ADJ. FOOT | 4 |
| 13a | 2932-M1 | 2932 MANIFOLD ASSY. - NAT. | 1 |
| 13b | 2932-M2 | 2932 MANIFOLD ASSY. - L.P. | 1 |

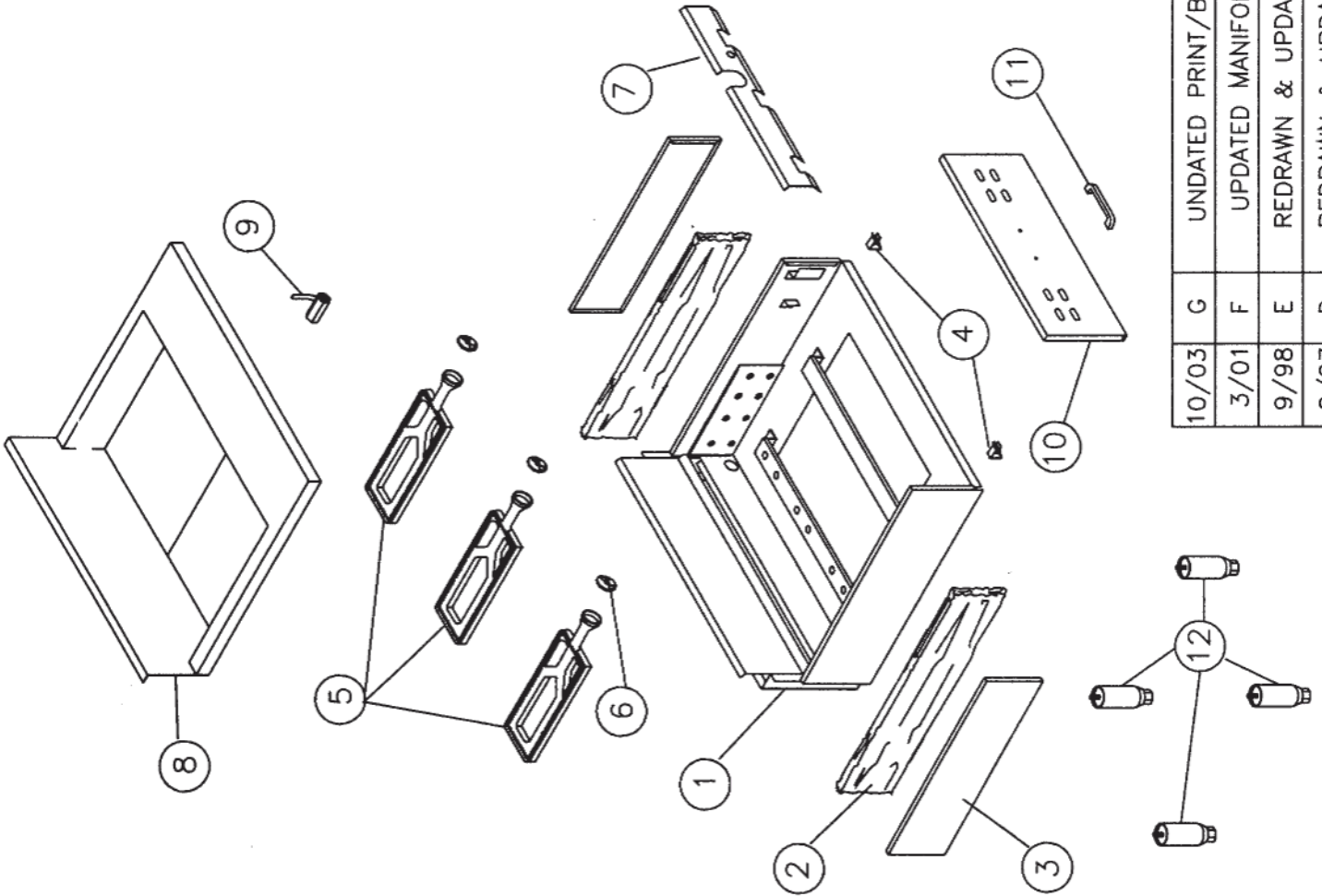

| | | |
|-------------------------------|------|--------------------|
| DR. BY. | DATE | BLANK |
| M.D. | 5/92 | GAGE |
| CHK. | DATE | QTY. |
| APPR. | DATE | MATL. |
| SCALE | DATE | WEIGHT |
| NTS | | PART NO. |
| REVISIONS | | 2932 UNIT ASSEMBLY |
| 10/03 G UNDATED PRINT/BOM MCD | | 2932SF |
| 3/01 F UPDATED MANIFOLD MCD | | |
| 9/98 E REDRAWN & UPDATED MCD | | |
| 9/97 D REDRAWN & UPDATED MCD | | |

COMSTOCK CASTLE STOVE CO.
 DEPARTMENT OF ENGINEERING
 119 W. WASHINGTON QUINCY, IL 62301

| ITEM NO. | PART NO. | DESCRIPTION | QTY. |
|----------|-----------|-----------------------------------|------|
| 1 | 11201B-BA | 11201B BODY ASSY. | 1 |
| 2 | NB67-201 | 11201B BURNER SHEILD | 1 |
| 3 | NB60-201A | 11201B APRON ASSY. | 1 |
| 4 | NB29-20W | 1120B WELDED DRIP PAN | 1 |
| 5 | NB28-20A | ASSY., 1120B STEAK PAN | 1 |
| 6 | 21014 | 1120B BROILER RACK | 1 |
| 7 | 18030 | KNOB, MANUAL ON-OFF F SERIES | 5 |
| 8a | 17006N | REGULATOR, CONVERTIBLE - NATURAL | 1 |
| 8b | 17006L | REGULATOR, CONVERTIBLE - L.P. | 1 |
| 9a | 11201B-M1 | 11201B MANIFOLD ASSY. - NAT. | 1 |
| 9b | 11201B-M2 | 11201B MANIFOLD ASSY. - L.P. | 1 |
| 10 | 25118 | ELBOW, 3/4" x 1/2", 90 DEG., BLK. | 1 |
| 11 | 25116 | ELBOW, 1/2" x 90 DEG., ST., BLK. | 1 |
| 12 | 26002-22 | PIPE, 1/2" x 22", SCH. 40, BLK. | 1 |
| 13 | 25149 | REDUCER, 3/4" TO 1/2", BELL, BLK. | 1 |
| 14 | 25124 | NIPPLE, 3/4" CLOSE | 1 |
| 15 | 16015-A | ASSY., "Y" TUBE BURNER | 1 |
| 16 | 16011-A | ASSY., CAST IRON STRING BURNER | 3 |
| 17 | NB75-30 | 1130B FLUE BACK | 1 |
| 18 | NB76-30 | 1130B FLUE FALSE BACK | 1 |
| 19 | 1120B-PA | 1120B PLATE ASSY. | 1 |
| 20 | V15-10 | 10 SER. TWO HOLE PLATE SUPPORT | 1 |
| 21 | 16034 | GRATE, #BR10 SPIDER RING TOP | 2 |
| 22 | V15R | RAIL, 10 SER. 2 HOLE PLATE SUP. | 2 |

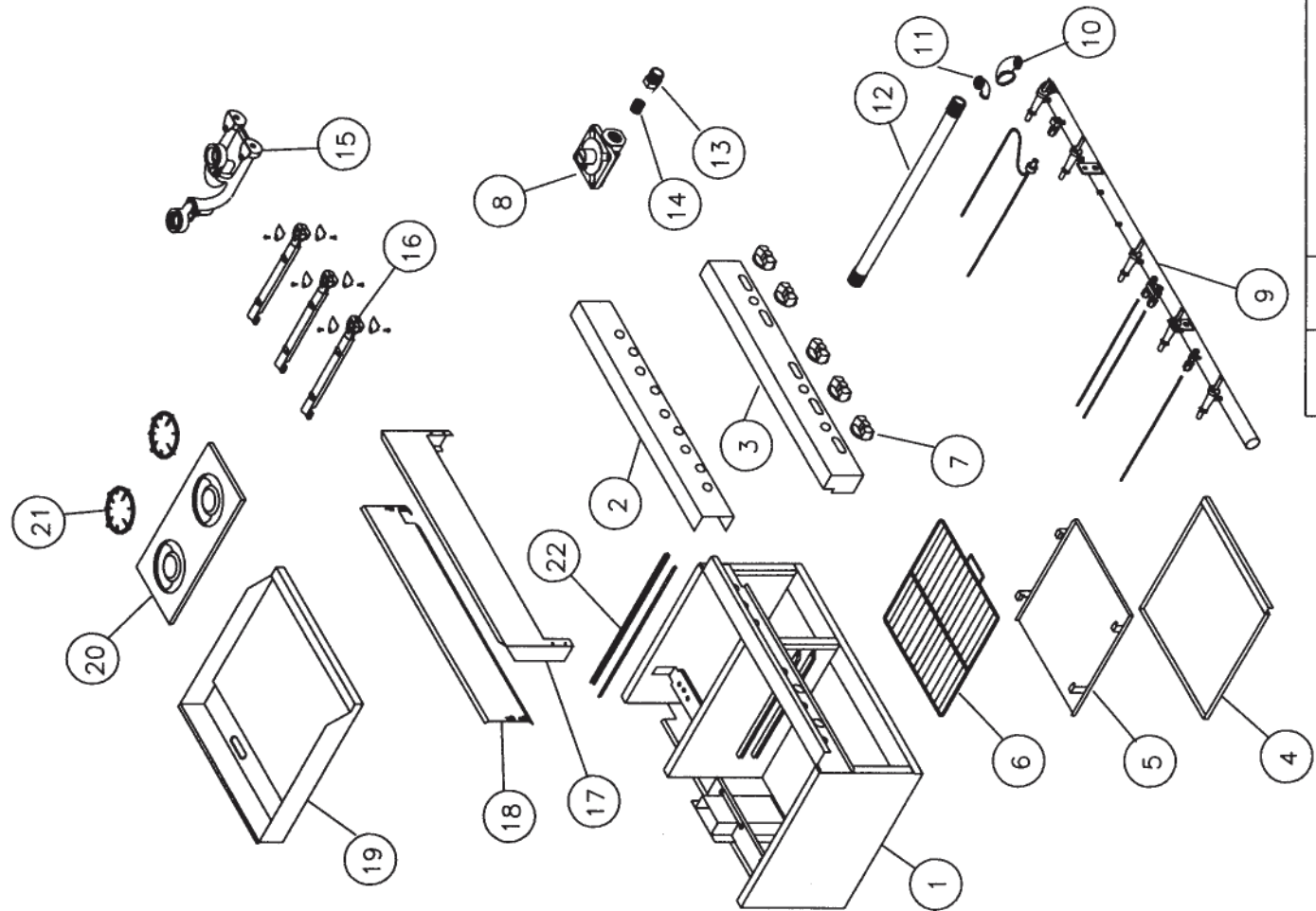

| | | | | |
|---------|------|-------|--|-------|
| DR. BY. | DATE | 11/03 |  | BLANK |
| MCD | CHK. | DATE | | GAGE |
| APPR. | DATE | | COMSTOCK CASTLE STOVE CO. DEPARTMENT OF ENGINEERING 119 W. WASHINGTON QUINCY, IL 62301 | |
| SCALE | NTS | TITLE | 11201B UNIT PART NO. 11201B | |

| DATE | REV. NO. | REVISIONS | CHK. BY |
|------|----------|-----------|---------|
| | | | |

PARTS LIST - RADIANT BROILER

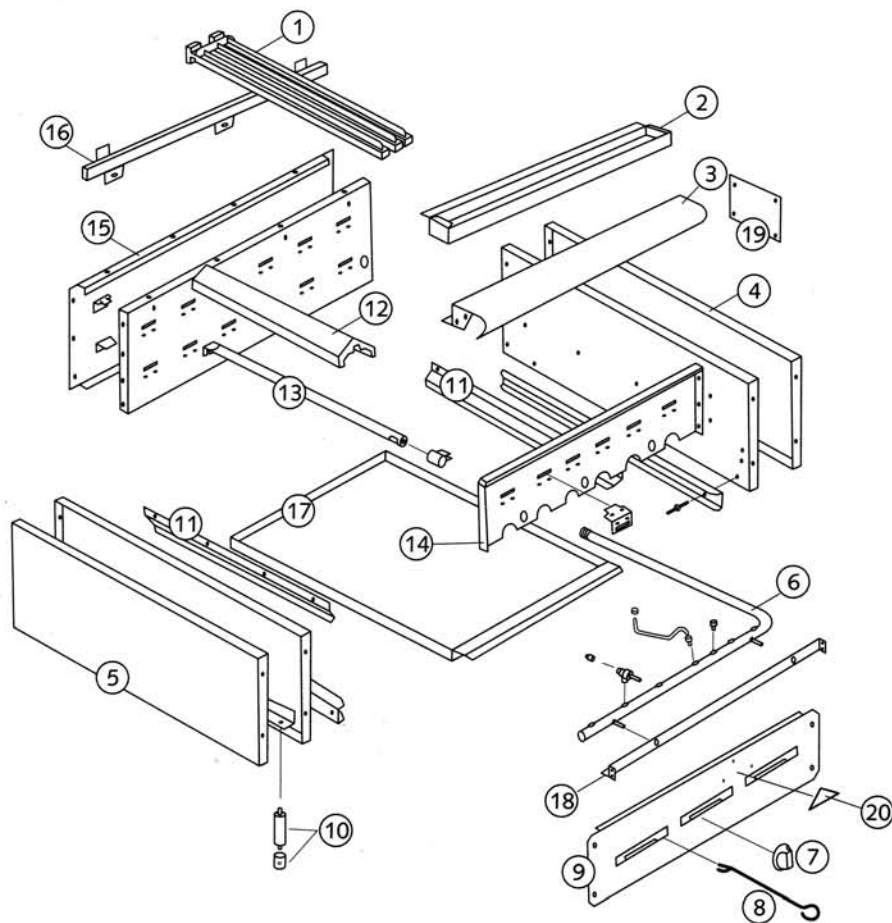

| ITEM | PART DESCRIPTION | SIZE | QTY | CODE |
|------|------------------------|------|-----|------------------|
| 1 | Grate (melted iron) | 18" | 6 | 2.18.02.00000001 |
| | | 24" | 7 | |
| | | 36" | 11 | |
| | | 48" | 15 | |
| 2 | Grease collector set | 18" | 1 | 3.31.01.18010000 |
| | | 24" | | 3.31.01.24010000 |
| | | 36" | | 3.31.01.36010000 |
| | | 48" | | 3.31.01.48010000 |
| 3 | Finishing panel | 18" | 1 | 3.31.01.18000001 |
| | | 24" | | 3.31.01.24000001 |
| | | 36" | | 3.31.01.36000001 |
| | | 48" | | 3.31.01.48000001 |
| 4 | Right side set | All | 1 | 3.31.01.00010000 |
| 5 | Left side set | All | 1 | 3.31.01.00020000 |
| 6a | Propane gas system set | 18" | 1 | 3.31.01.18060000 |
| | | 24" | | 3.31.01.24060000 |
| | | 36" | | 3.31.01.36060000 |
| | | 48" | | 3.31.01.48060000 |
| 6b | Natural gas system set | 18" | 1 | 3.31.01.18070000 |
| | | 24" | | 3.31.01.24070000 |
| | | 36" | | 3.31.01.36070000 |
| | | 48" | | 3.31.01.48070000 |
| 7 | Handle | 18" | 3 | 2.80.28.00002000 |
| | | 24" | 4 | |
| | | 36" | 6 | |
| | | 48" | 8 | |
| 8 | Wick stick set | All | 1 | 3.30.01.00070000 |
| 9 | Panel set | 18" | 1 | 3.31.01.18020000 |
| | | 24" | | 3.31.01.24020000 |
| | | 36" | | 3.31.01.36020000 |
| | | 48" | | 3.31.01.48020000 |
| 10 | Legs set | All | 4 | 2.80.10.00003617 |
| 11 | Lateral profile | All | 2 | 3.31.01.00000001 |

| ITEM | PART DESCRIPTION | SIZE | QTY | CODE |
|------|-------------------------|------|-----|------------------|
| 12 | Deflector (melted iron) | 18" | 3 | 2.18.02.00000002 |
| | | 24" | 4 | |
| | | 36" | 6 | |
| | | 48" | 8 | |
| 13 | Burner set | 18" | 3 | 3.31.01.00050000 |
| | | 24" | 4 | |
| | | 36" | 6 | |
| | | 48" | 8 | |
| 14 | Burner drawer set | 18" | 1 | 3.31.01.18030000 |
| | | 24" | | 3.31.01.24030000 |
| | | 36" | | 3.31.01.36030000 |
| | | 48" | | 3.31.01.48030000 |
| 15 | Back side set | 18" | 1 | 3.31.01.18040000 |
| | | 24" | | 3.31.01.24040000 |
| | | 36" | | 3.31.01.36040000 |
| | | 48" | | 3.31.01.48040000 |
| 16 | Grate support set | 18" | 1 | 3.31.01.18050000 |
| | | 24" | | 3.31.01.24050000 |
| | | 36" | | 3.31.01.36050000 |
| | | 48" | | 3.31.01.48050000 |
| 17 | Residue drawer | 18" | 1 | 3.31.01.18000002 |
| | | 24" | | 3.31.01.24000002 |
| | | 36" | | 3.31.01.36000002 |
| | | 48" | | 3.31.01.48000002 |
| 18 | Distributor support | 18" | 1 | 3.31.01.18000003 |
| | | 24" | | 3.31.01.24000003 |
| | | 36" | | 3.31.01.36000003 |
| | | 48" | | 3.31.01.48000003 |
| 19 | Identification tag | 18" | 1 | 2.90.02.00000028 |
| | | 24" | | 2.90.02.00000004 |
| | | 36" | | 2.90.02.00000005 |
| | | 48" | | 2.90.02.00000006 |
| 20 | Logo Castle | All | 1 | 2.90.02.00000989 |

PARTS LIST - LAVA BROILER

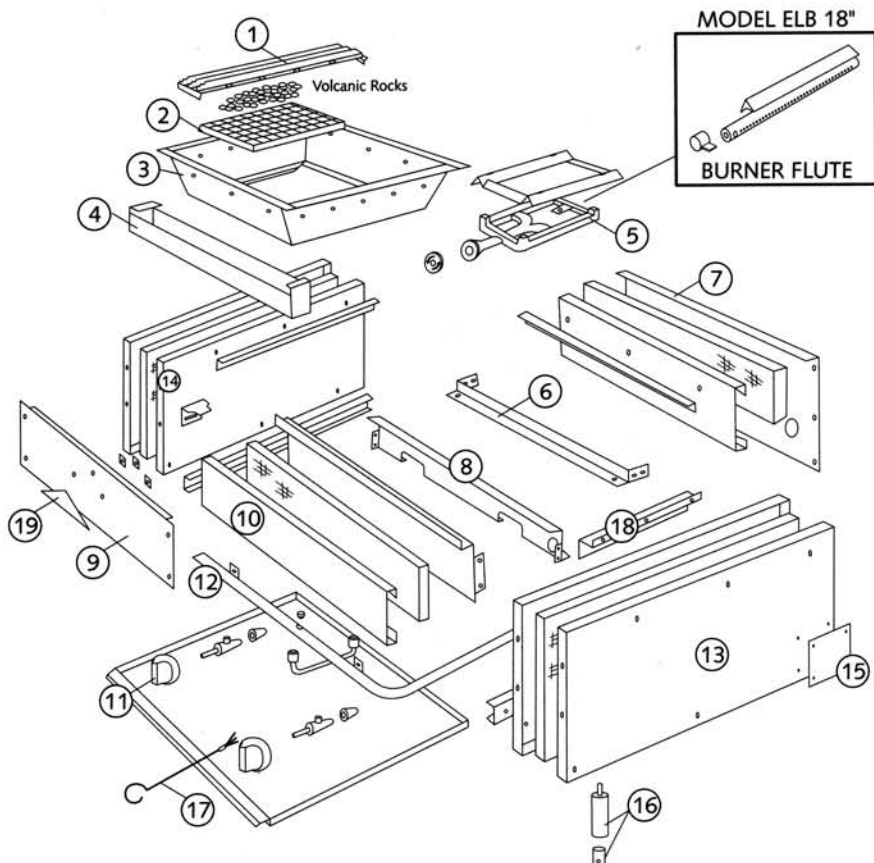

| ITEM | PART DESCRIPTION | SIZE | QTY | CODE |
|------|----------------------|------|-----|------------------|
| 1 | Superior grate GG15 | 18" | 5 | 4.03.04.00000011 |
| | | 24" | 7 | |
| | | 36" | 11 | |
| | | 48" | 15 | |
| 2 | Inferior grate GG15 | 18" | 2 | 4.03.04.00000012 |
| | | 24" | 3 | |
| | | 36" | 5 | |
| | | 48" | 7 | |
| 3 | Internal box set | 18" | 1 | 3.32.01.18010000 |
| | | 24" | | 3.32.01.24010000 |
| | | 36" | | 3.32.01.36010000 |
| | | 48" | | 3.32.01.48010000 |
| 4 | Grease collector set | 18" | 1 | 3.32.01.18020000 |
| | | 24" | | 3.32.01.24020000 |
| | | 36" | | 3.32.01.36020000 |
| | | 48" | | 3.32.01.48020000 |
| 5 | Burner set | 18" | 3 | 3.32.01.18090000 |
| | Burner set GG15 | 24" | 2 | 4.03.04.00000013 |
| | | 36" | 3 | |
| | | 48" | 4 | |
| 6 | Burner set support | 18" | 1 | 3.32.01.18030000 |
| | | 24" | | 3.32.01.24030000 |
| | | 36" | | 3.32.01.36030000 |
| | | 48" | | 3.32.01.48030000 |
| 7 | Back side set | 18" | 1 | 3.32.01.18040000 |
| | | 24" | | 3.32.01.24040000 |
| | | 36" | | 3.32.01.36040000 |
| | | 48" | | 3.32.01.48040000 |
| 8 | Burner drawer | 18" | 1 | 3.32.01.18000001 |
| | | 24" | | 3.32.01.24000001 |
| | | 36" | | 3.32.01.36000001 |
| | | 48" | | 3.32.01.48000001 |

| ITEM | PART DESCRIPTION | SIZE | QTY | CODE |
|------|----------------------------|---------|------------------|------------------|
| 9 | Panel set | 18" | 1 | 3.32.01.18050000 |
| | | 24" | | 3.32.01.24050000 |
| | | 36" | | 3.32.01.36050000 |
| | | 48" | | 3.32.01.48050000 |
| 10 | Frontal fiber rock box set | 18" | 1 | 3.32.01.18060000 |
| | | 24" | | 3.32.01.24060000 |
| | | 36" | | 3.32.01.36060000 |
| | | 48" | | 3.32.01.48060000 |
| 11 | Handle | 24" | 2 | 2.80.28.00003000 |
| | | 18"/36" | 3 | |
| | | 48" | 4 | |
| 12a | Propane gas system set | 18" | 1 | 3.32.01.18070000 |
| | | 24" | | 3.32.01.24070000 |
| | | 36" | | 3.32.01.36070000 |
| 12b | Natural gas system set | 48" | 1 | 3.32.01.48070000 |
| | | 18" | | 3.32.01.18080000 |
| | | 24" | | 3.32.01.24080000 |
| | | 36" | | 3.32.01.36080000 |
| | | 48" | 3.32.01.48080000 | |
| 13 | Right side set | All | 1 | 3.32.01.00030000 |
| 14 | Left side set | All | 1 | 3.32.01.00040000 |
| 15 | Identification tag | 18" | 1 | 2.90.02.00000030 |
| | | 24" | | 2.90.02.00000010 |
| | | 36" | | 2.90.02.00000011 |
| | | 48" | | 2.90.02.00000012 |
| 16 | Legs set | All | 4 | 2.80.10.00003617 |
| 17 | Wick stick set | All | 1 | 3.32.01.00070000 |
| 18 | Distributor pipe protector | All | 1 | 3.32.01.00000001 |
| 19 | Logo Castle | All | 1 | 2.90.02.00000989 |

PARTS LIST - GRIDDLE

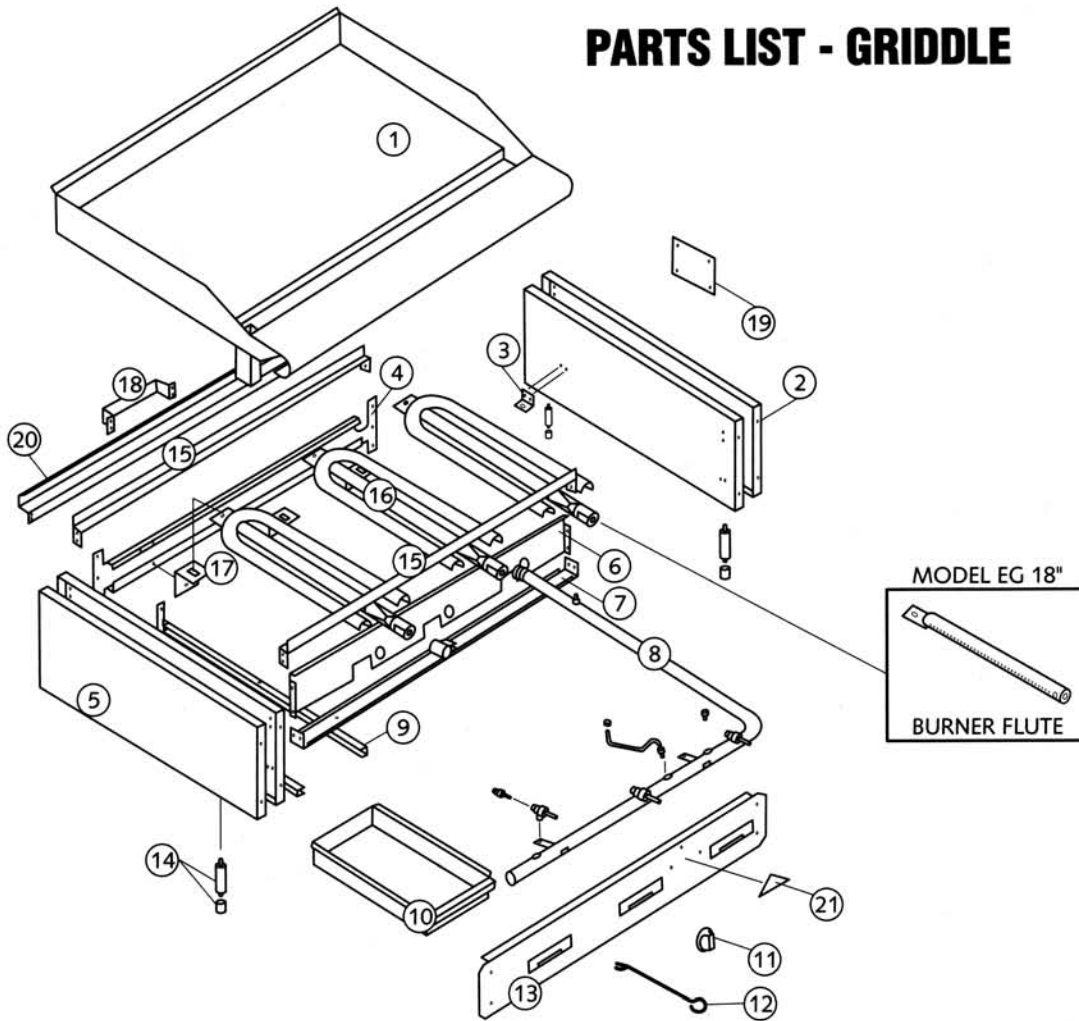

| ITEM | PART DESCRIPTION | SIZE | QTY | CODE |
|------|--------------------------|------|-----|------------------|
| 1 | Plate set | 18" | 1 | 3.30.01.18010000 |
| | | 24" | | 3.30.01.24010000 |
| | | 36" | | 3.30.01.36010000 |
| | | 48" | | 3.30.01.48010000 |
| 2 | Right side set | All | 1 | 3.30.01.00010000 |
| 3 | Distributor pipe fixing | All | 1 | 3.30.01.00020000 |
| 4 | Back side | 18" | 1 | 3.30.01.18000001 |
| | | 24" | | 3.30.01.24000001 |
| | | 36" | | 3.30.01.36000001 |
| | | 48" | | 3.30.01.48000001 |
| 5 | Right side set | All | 1 | 3.30.01.00030000 |
| 6 | Burner drawer | 18" | 1 | 3.30.01.18000002 |
| | | 24" | | 3.30.01.24000002 |
| | | 36" | | 3.30.01.36000002 |
| | | 48" | | 3.30.01.48000002 |
| 7 | Distributor pipe support | 18" | 1 | 3.30.01.18000003 |
| | | 24" | | 3.30.01.24000003 |
| | | 36" | | 3.30.01.36000003 |
| | | 48" | | 3.30.01.48000003 |
| 8a | Propane gas system set | 18" | 1 | 3.30.01.18040000 |
| | | 24" | | 3.30.01.24040000 |
| | | 36" | | 3.30.01.36040000 |
| | | 48" | | 3.30.01.48040000 |
| 8b | Natural gas system set | 18" | 1 | 3.30.01.18050000 |
| | | 24" | | 3.30.01.24050000 |
| | | 36" | | 3.30.01.36050000 |
| | | 48" | | 3.30.01.48050000 |
| 9 | Drawer track set | All | 2 | 3.30.01.00060000 |
| 10 | Residue drawer | 18" | 1 | 3.30.01.00000001 |
| | | 24" | | |
| | | 36" | | |
| | | 48" | | |

| ITEM | PART DESCRIPTION | SIZE | QTY | CODE |
|------|----------------------|---------|-----|------------------|
| 11 | Handle | 24" | 2 | 2.80.28.00002000 |
| | | 18"/36" | | |
| | | 48" | | |
| | | 48" | | |
| 12 | Wick stick set | All | 1 | 3.30.01.00070000 |
| 13 | Panel set | 18" | 1 | 3.30.01.18020000 |
| | | 24" | | 3.30.01.24020000 |
| | | 36" | | 3.30.01.36020000 |
| | | 48" | | 3.30.01.48020000 |
| 14 | Legs set | All | 4 | 2.80.10.00004485 |
| | | 18" | | 3.30.01.18030000 |
| | | 24" | | 3.30.01.24030000 |
| | | 36" | | 3.30.01.36030000 |
| 15 | Plate support set | 18" | 2 | 3.30.01.18060000 |
| | | 24" | | 3.30.01.24030000 |
| | | 36" | | 3.30.01.36030000 |
| | | 48" | | 3.30.01.48030000 |
| 16 | Burner set | 18" | 3 | 3.30.01.18060000 |
| | | 24" | | 3.30.01.00080000 |
| | | 36" | | 3.30.01.00080000 |
| | | 48" | | 3.30.01.00080000 |
| 17 | Burner support | 18" | 3 | 3.30.01.18000005 |
| | | 24" | | 3.30.01.00000002 |
| | | 36" | | 3.30.01.00000002 |
| | | 48" | | 3.30.01.00000002 |
| 18 | Back side protection | All | 1 | 3.30.01.00000003 |
| | | 18" | | 2.90.02.00000029 |
| | | 24" | | 2.90.02.00000007 |
| | | 36" | | 2.90.02.00000008 |
| 19 | Identification set | 48" | 1 | 2.90.02.00000009 |
| | | 18" | | 3.30.01.18000006 |
| | | 24" | | 3.30.01.24000006 |
| | | 36" | | 3.30.01.36000006 |
| 20 | Chimney | 48" | 1 | 3.30.01.48000006 |
| | | 18" | | 3.30.01.18000006 |
| | | 24" | | 3.30.01.24000006 |
| | | 36" | | 3.30.01.36000006 |
| 21 | Logo Castle | All | 1 | 2.90.02.00000989 |

TROUBLESHOOTING CHART

| PROBLEM | PROBABLE CAUSE | POSSIBLE SOLUTION |
|--|---|---|
| 1. Appliance will not ignite. | 1a. No gas. 1b. Air in gas line. 1c. Improper gas line supply. 1d. Gas turned on too fast at tank. | 1a. Ensure gas is turned on. 1b. Purge air from gas line. 1c. Ensure piping will supply adequate pressure. 1d. Turn on at tank very slowly. |
| 2. Pilots will not light. | 2a. Pilot valve is shut off. 2b. Fans or air drafts interfering with pilot operation. 2c. Improper pilot adjustment. 2d. Bad or weak thermocouple. 2e. Bad or weak electromechanical head in valve. | 2a. Locate and adjust pilot. 2b. Locate and eliminate air drafts. 2c. Locate and adjust pilot. 2d. Have a technician properly test the thermocouple. 2e. Test safety valve with a turn down test. <i>CALL FOR SERVICE BULLETIN</i> |
| 3. Yellow flame or yellow tipped flame on burners. | 3a. Lack of primary air supply. 3b. Improper pressure. | 3a. Thoroughly clean and/or adjust air mixer. 3b. Check and adjust manifold pressure. <ul style="list-style-type: none"> • Check orifice drill size. • Ensure gas stream enters center of mixing tube. • Check mixing tube for obstructions. |
| 4. Orange flame. | 4a. Dirt and /or dust are being carried through burner ports. | 4a. Clean inside burner and burner ports with small brush and blow out burner with air. (correction needed only in exceptional cases.) |
| 5. Flame lifts above burner ports. | 5a. Too much primary air. 5b. Improper manifold pressure. | 5a. Reduce the amount of primary air. 5b. Check and adjust manifold pressure. <ul style="list-style-type: none"> • Check for proper orifice drill size. 5c. Lift back of plate with adjusting screws 1/8". |
| 6. Delayed ignition or slow lighting. | 6a. Improper manifold pressure. 6b. Pilot flame improperly located. 6c. Too much primary air. | 6a. Check and adjust manifold pressure. 6b. Properly adjust and locate pilot assembly. 6c. Adjust primary air. |
| 7. Odor: gas/combustion. | 7a. Gas odor: leak in appliance. 7b. Combustion odor: lack of secondary air. | 7a. Check appliance thoroughly for gas leaks with soap solution - bubbles. 7b. Ensure air and flue passages are clean. |
| 8. Floating flame. | 8a. Lack of secondary air. | 8a. Check secondary air vent passages for obstruction. Check for adequate air intake to combustion chamber. 8b. Lift back of plate with adjusting screws 1/8". |
| 9. Noise: 9a. Explosion inside burner when flame is shut off. 9b. Noise in air mixer and mixing tube. 9c. Whistling noise in orifice. | 9a. Burner head too hot. 9b. Flame inside burner. 9c. Faulty adjustment - seating. | 9a. Check manifold pressure and adjust if necessary. <ul style="list-style-type: none"> • Check for proper orifice size. 9b. Obstruction in orifice - clean or replace orifice hood. 9c. Make sure orifice is tight. Replace orifice hood, if necessary, making sure orifice is properly drilled. |
| 10. Uneven or improper heating on griddle plate. | 10a. Thermostat improperly adjusted. 10b. Improper orifice size. 10c. Improper griddle plate temperature. 10d. Misaligned by-pass adjustment. 10e. Bad thermostat. | 10a. Check and adjust manifold pressure and primary air to burner. 10b. Check orifice size. 10c. Check and properly calibrate thermostat. 10d. Check and, if necessary, adjust the by-pass on thermostat. 10e. Check thermostat for proper seating against bottom of plate. 10f. Replace thermostat. |
| 11. Valve hard to turn. | 11a. Valve grease drying out internally. | 11a. Periodic maintenance with hi-temperature valve grease. <i>CALL FOR SERVICE BULLETIN</i> |

If problems arise during warranty time period, please call factory for authorized service agency. Manufacturing drawings of parts and manifolds are available from the factory. Please call if needed.

COMSTOCK-CASTLE WARRANTY

Comstock-Castle Stove Co. (hereinafter Factory), warrants its new product(s) to be free from defects in material and workmanship under normal use for a period of one (1) year from the date of original installation, not to exceed eighteen (18) months after shipment from Factory or Factory facility. Factory warranty covers the contiguous United States, Alaska, and Hawaii for both parts and labor. This warranty is extended to the original commercial user and is not transferable. Initial installation, including calibration, is considered to be a customer responsibility. The initial installation must be accomplished by an authorized service technician or a licensed plumber who is familiar with gas and combustion systems, or this warranty will be considered to be void. Reasonable service/labor costs, as defined by the factory, will be paid for a period not exceeding 90 days from the date of installation/calibration. Original parts will be replaced for one year from the date of initial installation, upon return (at customer's expense) of the defective part, at no charge to the customer for the part or outbound shipping. Expenses for shipping of parts requested by 2nd day or next day service will be at customer's expense.

PROVISIONS:

- A) **Proof of installation date MUST BE SUBMITTED on the factory supplied Warranty Registration/ Installation Checklist prior to work being performed.**
- B) Such repair shall be performed within fifty (50) miles from an office of a **Factory Authorized Service Agency** or sub-agent or any other licensed agent approved in writing by factory.
- C) The equipment has not been damaged, altered, or misused.
- D) The equipment is properly installed, adjusted, operated, and maintained in accordance with national, state, and local codes for commercial kitchens and in accordance with the installation instructions provided with this product.
- E) The warranty serial number plaque affixed to the appliance has not been defaced, obliterated, or removed.
- F) An acceptable report for any claim under this warranty shall be supplied to Factory within (30) days of the work performed.
- G) Comstock-Castle shall not be liable, whether in contract or in tort, or under any other legal theory, for loss of use, revenue or profit, or for substitute use of performance, for incidental, indirect, or special, or consequential damages, or for any other loss of cost of similar type.

EXCLUSIONS:

- A) Factory shall have no obligation as to any product(s) which have been misapplied, mishandled, abused, misused, subjected to harsh chemical action, or poor water/gas quality, modified without written approval from the factory, damaged by flood, fire, or other acts of nature.
- B) Re-calibrations associated with the replacement of a defective part otherwise covered under this warranty for labor will be covered to the extent of one (1) service call (i.e. the call during which the part is replaced).
- C) Factory assumes no responsibility for travel costs beyond 100 miles round trip. travel other than overland and overtime costs of repair.
- D) Factory excludes paint and procelain finish, gasket material, ceramic material from normal coverage.
- E) Factory liability on a claim of warranty shall not exceed the price of the material and/or service which caused the claim.
- F) This warranty is limited and is lieu of all other warranties, expressed, or implied. Factory employees or agents shall not be held liable for any claims of personal injury, or consequential damage or loss.
- G) Factory assumes no responsibility for installation, adjustments, diagnosis, or normal maintenance such as lubrication of springs or valves.

SUBSTITUTIONS:

In line with our policy to continually improve our product, Comstock-Castle reserves the right to change materials and specifications without notice.

RETURN:

Return allowed within 90 days of invoice date, with prior written authorization from the factory, shipped freight prepaid. Equipment must be unused and in packaging acceptable for a damage free return. A 20% restocking charge is assessable.